

NORDENHAM

# Technology in motion

THREE-PHASE MOTORS WITH  
FLAMEPROOF ENCLOSURES





We move your ideas. We don't just manufacture motors - we turn our customers' ambitious ideas into modern, innovative and reliable products that are unique and trend-setting. We take our customers to their goal with reliability, creativity and flexibility.

---

General information

---

Structural designs                      Designs, special versions of motors

---

Electrical design

---

Operating characteristics

---

Operating data                      Low voltage motors

High voltage motors

---

Dimensions

---

Spare parts

---

Conversions and formulas

---

Service partners

## General Information

Degrees of efficiency	6
Certificates and standards	8
Explosion protection	10
• Ingintion types of electrical machines	10
• Ignition protection types and categories of electrical machines	12
Type code	16

## Structural designs

Types	17
Materials, signage	18
Installation at normal, elevated and low temperatures	19
Painting, protection types, tropicalized version	20
Terminal compartments	21
Direct cable entry	23
Bearing	24
• Bearing assignment	25
• Bearing and seal arrangement	26
• Permissible radial load, deep groove ball bearings	27
• Permissible axial load, deep groove ball bearings	28
• Permissible radial load, cylindrical roller bearing	29
• Rotor weights CD...(Y2, Y3, Y) series	30
• Lubrication, bearing monitoring	31
• Bearing currents, isolated bearings, mechanical limiting speeds	32
Shaft ends, balancing, vibration severity, gearbox mounting and foundations	33
Operating noise, cooling air volume	34
Customised motors	35
• Low noise motors	35
• Low noise motors, sound level	36
• Top deck installation according to classification societies	37
• Universal chemistry motor	38
• Attachments and installations, speed sensor, backstop	39
• Brake motors with mounted brake type CD...SM(N)	40
• Brake motors with mounted brake type CD...SV(N) and type CD...S	43
• Brake motors with built-in brake	44
Three-phase asynchronous motors with integrated frequency inverter (compact drives)	46
High voltage motors	48

## Electrical design

Protective devices, stationary heating	50
Electrical design for motors up to 690 V	52

## Operating characteristics

<b>Operating characteristics for motors up to 690 V</b>	53
• Permissible start-up times for standard motors, temperature class T4, protection by PTC thermistor temperature sensor	54
• Permissible switching frequencies for standard motors, temperature class T4, protection by PTC thermistor temperature sensor	55
Operation at frequency inverter	56
• Torque curve at frequency inverter, 50 Hz mains, temperature class T4, 2p = 2	58
• Torque curve on frequency inverter, 50 Hz mains, temperature class T4, 2p = 4 to 8	59
• Torque curve at frequency inverter, 60 Hz mains, temperature class T4, 2p = 2	60
• Torque curve on frequency inverter, 60 Hz mains, temperature class T4, 2p = 4 to 8	61

## Operating data, low-voltage motors

### Mains operation and inverter operation

• IE3, Mains operation 50 Hz, temperature class T4, ns = 3000 rpm, 2p = 2	62
• IE3, Mains operation 50 Hz, temperature class T4, ns = 1500 rpm, 2p = 4	63
• IE3, Mains operation 50 Hz, temperature class T4, ns = 1000 rpm, 2p = 6	64
• IE3, Mains operation 50 Hz, temperature class T4, ns = 750 rpm, 2p = 8	65
• IE3, Mains operation 60 Hz, temperature class T4, ns = 3600 rpm, 2p = 2	66
• IE3, Mains operation 60 Hz, temperature class T4, ns = 1800 rpm, 2p = 4	67
• IE3, Mains operation 60 Hz, temperature class T4, ns = 1200 rpm, 2p = 6	68

• IE3, Mains operation 60 Hz, temperature class T4, ns = 900 rpm, 2p = 8	69
• IE1, Mains operation 50 Hz, temperature class T4, ns = 3000 rpm, 2p = 2	70
Inverter operation 50 Hz, temperature class T4, ns = 3000 rpm, 2p = 2	71
• IE1, Mains operation 50 Hz, temperature class T4, ns = 1500 rpm, 2p = 4	72
Inverter operation 50 Hz, temperature class T4, ns = 1500 rpm, 2p = 4	73
• IE1, Mains operation 50 Hz, temperature class T4, ns = 1000 rpm, 2p = 6	74
Inverter operation 50 Hz, temperature class T4, ns = 1000 rpm, 2p = 6	75
• IE1, Mains operation 50 Hz, temperature class T4, ns = 750 rpm, 2p = 8	76
Inverter operation 50 Hz, temperature class T4, ns = 750 rpm, 2p = 8	77
• IE1, Mains operation 60 Hz, temperature class T4, ns = 3600 rpm, 2p = 2	78
Inverter operation 60 Hz, temperature class T4, ns = 3600 rpm, 2p = 2	79
• IE1, Mains operation 60 Hz, temperature class T4, ns = 1800 rpm, 2p = 4	80
Inverter operation 60 Hz, temperature class T4, ns = 1800 rpm, 2p = 4	81
• IE1, Mains operation 60 Hz, temperature class T4, ns = 1200 rpm, 2p = 6	82
Inverter operation 60 Hz, temperature class T4, ns = 1200 rpm, 2p = 6	83
• IE1, Mains operation 60 Hz, temperature class T4, ns = 900 rpm, 2p = 8	84
Inverter operation 60 Hz, temperature class T4, ns = 900 rpm, 2p = 8	85
• IE2, Mains operation 50 Hz, temperature class T4, ns = 3000 rpm, 2p = 2	86
Inverter operation 50 Hz, temperature class T4, ns = 3000 rpm, 2p = 2	87
• IE2, Mains operation 50 Hz, temperature class T4, ns = 1500 rpm, 2p = 4	88
Inverter operation 50 Hz, temperature class T4, ns = 1500 rpm, 2p = 4	89
• IE2, Mains operation 50 Hz, temperature class T4, ns = 1000 rpm, 2p = 6	90
Inverter operation 50 Hz, temperature class T4, ns = 1000 rpm, 2p = 6	91
• IE2, Mains operation 50 Hz, temperature class T4, ns = 750 rpm, 2p = 8	92
Inverter operation 50 Hz, temperature class T4, ns = 750 rpm, 2p = 8	93
• IE2, Mains operation 60 Hz, temperature class T4, ns = 3600 rpm, 2p = 2	94
• IE2, Mains operation 60 Hz, temperature class T4, ns = 1800 rpm, 2p = 4	95

## Partial load data

IE3 Partial load data 50 Hz	96
• Power factor	97
IE1 Partial load data 50 Hz	98
• Power factor	99
IE2 Partial load data 50 Hz	100
• power factor	101
• Increased performance, mains operation 50 Hz, temperature class T4, ns = 3000 rpm, 2p = 2	102
• Increased performance, mains operation 50 Hz, temperature class T4, ns = 1500 rpm, 2p = 4	103
• Increased performance, mains operation 60 Hz, temperature class T4, ns = 3600 rpm, 2p = 2	104
• Increased performance, mains operation 60 Hz, temperature class T4, ns = 1800 rpm, 2p = 4	105
• Pole-changing motors, mains operation 50 Hz, temperature class T4, ns = 1500/3000 rpm, 2p = 4/2	106
• Pole-changing motors, mains operation 50 Hz, temperature class T4, ns = 1000/1500 rpm, 2p = 6/4	107
• Pole-changing motors, mains operation 50 Hz, temperature class T4, ns = 750/1500 rpm, 2p = 8/4	108
• Pole-changing motors, mains operation 50 Hz, temperature class T4, fan version	109
• Pole-changing motors, mains operation 60 Hz, temperature class T4	110
• Pole-changing motors, mains operation 60 Hz, temperature class T4, fan version	111
• IE 1 Motors with built in brake, mains operation 50 Hz, temperature class T4, 2p = 2, 4, 6, 8	112
• IE 3 Motors with built-in brake, mains operation 50 Hz, temperature class T4, 2p = 2, 4, 6, 8	113

IE 1 Motors with mounted brake, mains operation 50 Hz, temperature class T4, 2p = 8/4, 8/2	114
Mounted brakes for motors, mains operation 50 Hz, • Temperature class T4, Type CD...SM and ...SMN	115
• Temperature class T4, Type CD...S, type CD...SV and ...SVN	116
Coil data for brakes	117
IE 3, Three-phase asynchronous motors with Integrated frequency inverter, Compact drive, Temperature class T4, 2p = 2, 4	118
Noise class 4, water-cooled motors, mains operation 50 Hz, 2p = 2, 4, temperature class T4	119

## Operating data, high voltage motors

High voltage motors, mains operation 50 Hz, Temperature class T4, 2p = 2, 4, 6, 8	120
--	-----

## Dimensions

### IE3 / IE2, Surface-cooling low-voltage motors, Self-cooled with radial ventilation, forced cooling with axial ventilation

• IE3 / IE2 Type IM B3, IM B6, IM B7, IM B8, IM V5, IM V6	122
• IE1 Type IM B3, IM B6, IM B7, IM B8, IM V5, IM V6	124
• IE3 / IE2, Type IM B5, IM V1, IM V3	126
• IE1 Type IM B5, IM V1, IM V3	128
• IE3 / IE2 Type IM B14, IM B34, IM V17, IM V18, IM V19, IM V37	130
• IE1 Type IM B14, IM B34, IM V1, IM V18, IM V19, V37	131

### Self-cooled with axial ventilation, noise class 2 and 3

• IE3 / IE2, Type IM B3, IM B6, IM B7, IM B8, IM V5, IM V6	132
• IE1 Type IM B3, IM B6, IM B7, IM B8, IM V5, IM V6	134
• IE3 / IE2, Type IM B5, IM V1, IM V3	136
• IE1 Type IM B5, IM V1, IM V3	138

### Water-cooled low-voltage motors, noise class 4

Type IM B3, IM B6, IM B7, IM B8, IM V5, IM V6	140
---	-----

### Surface-cooled low voltage motors

• Motors with integrated frequency inverter	142
• Motors with built-in brake and built-in encoder	143
• Motors with mounted brake type CD... SM and ...SMN	144
• Motors with mounted brake type CD...S, type CD...SV and ...SVN	145

### Surface-cooled high voltage motors, Self-cooling with radial fan

All designs	146
-------------	-----

Terminal compartments up to 690 V	147
-----------------------------------	-----

Spare parts	148
-------------	-----

Wiring diagram	150
----------------	-----

## Conversion of technical units of Measurement

in SI units of measure	151
------------------------	-----

Your service partner	152
----------------------	-----

The idea of safety, durability and environmental friendliness has always been rooted in our company philosophy. This led us to develop energy-saving motors at an early stage, irrespective of the latest European directives concerning careful and responsible use of energy and resources.

## IEC 60034-30

In order to bring together the many different national efficiency requirements that have arisen to date, the international IEC 60034-30 standard is the first step towards globally uniform efficiency classes for three-phase low-voltage motors within the output range from 0.75 kW to 375 kW.

The abbreviation IE for International Efficiency is used to define efficiency classes IE1, IE2, IE3, .... The new edition of IEC 60034-30-1:2014 for mains operation adds another class (IE4) and extends the output range to 0.12 kW to 1000 kW. Values for class IE5 are mentioned informatively. Inverter operation is now regulated in IEC 60034-30-2.

The main difference between the old voluntary commitment of the European Sector Committee for Electric Drives CEMEP from 1998 and today's globally uniform requirements, apart from the reversed order of the numbering, also lies in the obligation to measure the degrees of efficiency in accordance with the new procedures of IEC 60034-2-1.

The scope of IEC 60034-30-1 includes motors with the following characteristics:

- 50 Hz and/or 60 Hz
- Rated voltage up to 1000 V
- Rated output from 0.12 kW to 1000 kW
- Number of poles 2, 4, 6 or 8
- S1 - Continuous operation and other modes where the motor is suitable for continuous operation at the rated output.
- Ambient temperature: -20 °C to +60 °C
- Installation altitude up to 4000 m

## EuP Directive 2005/32/EC and ErP Directive 2009/125/EC

In Europe, the legal basis for the implementation of environmental policy goals to reduce CO<sub>2</sub> emissions is the EuP Directive (2005/32/EC, Energy using Products). It was extended in a new version in 2009, in order to cover the eco-design of all energy-related products (ErP directive; 2009/125/EC).

The directive provides the framework for numerous different, product-related implementing regulations.

## Motor Regulation No. 2019/1781 and 2021/341

Regulation 640/2009 established requirements for the environmentally compatible design ("ecodesign") of electric motors and the use of electronic speed control systems with regard to placement on the market and commissioning for the first time.

The requirements also apply when the motors are installed in other products.

As of July 1, 2021, successor regulations 2019/1781 and 2021/341 apply.

Compared to 640/2009 and the IEC 60034-30 standard some of the scope has changed, and a schedule for implementing the requirements is provided.

Staggered according to different deadlines, some of the previous exemptions have been removed, such as:

- FI operation and brake motors now come under the efficiency requirements.
- Explosion-proof motors in the sense of directive 2014/34/EU (ATEX) of groups II and III must be taken into consideration (only Ex e motors remain an exception until 6/2023).
- As of July 1, 2023, 2-, 4- and 6-pole motors within the ofrange 75 - 200 kW must be supplied in accordance with IE4.

Excluded from the ErP engine regulation, for example, were motors:

- with rated voltages  $\leq 50$  V.
- which are an integral part of a power unit, compact drive or brake motor and cannot be tested independently.
- which reach operating temperatures above 400 °C .
- which operate at ambient temperatures below -30 °C .
- whose coolant temperatures at the inlet of a product are below 0 °C or above 32 °C .
- which are completely immersed in liquid.
- which are completely enclosed and self-cooled (TENV).
- which act as replacements for identical engines integrated into products which were placed on the market before July 1, 2021 (Ex d) or July 1, 2023 (Ex e).

The legal requirements only concern the first placement of a motor on the market by the European manufacturer or importer in the EU area.

Motors that were already placed on the market may continue to be sold and put into operation after the cut-off dates.

Although it will not be mandatory for explosion-proof motors until 7/2021, our motors have complied with the efficiency classes specified by the IEC 60034-30-1 standard, among others, since 2006.

Depending on the design, the following requirements are achieved:

1. Class IE2 - High efficiency in accordance with IEC 60034-30-1
2. Class IE3 - Premium efficiency in accordance with IEC 60034-30-1
3. Level 2 + 3 - China Energy Label in accordance with GB 18613-2020

### Marking

Motors of this version contain the letter "Y" in the type designation, and are marked with the associated efficiency class IE and the efficiency, e.g. CD 80M1-2Y3 IE3 - 82.8 %.

The high efficiencies are achieved by:

1. Increasing the diameter and lengthening the plate packages, while maintaining the axle height-related IEC mounting dimensions
2. Increasing the use of copper
3. Using higher quality dynamo plate
4. Using lower-loss shaft seals for protection class IP 55 and IP 56
5. Adjusting the ventilation system for standard and low-noise version (CD...A)

Output [kW]	IEC	IEC	IEC	IEC	IEC	IEC	IEC	IEC	IEC
	IE2	IE3	IE2	IE3	IE2	IE3	IE2	IE3	IE3
	CD...Y2	CD...Y3	CD...Y2	CD...Y3	CD...Y2	CD...Y3	CD...Y2	CD...Y3	CD...Y3
	2-pole		4-pole		6-pole		8-pole		
0,12	53,6	60,8	59,1	64,8	50,6	57,7	40,1	50,9	
0,18	60,4	65,9	64,7	69,9	56,6	63,9	48,7	58,4	
0,2	61,9	67,2	65,9	71,1	58,2	65,4	50,9	60,4	
0,25	64,8	69,7	68,5	73,5	61,6	68,6	55,4	64,4	
0,37	69,5	73,8	72,7	77,3	67,6	73,5	62,8	70,4	
0,4	70,4	74,6	73,5	78	68,8	74,4	64,1	71,3	
0,55	74,1	77,8	77,1	80,8	73,1	77,2	69,1	73,9	
0,75	77,4	80,7	79,6	82,5	75,9	78,9	71,9	76,4	
1,1	79,6	82,7	81,4	84,1	78,1	81	74,7	78,8	
1,5	81,3	84,2	82,8	85,3	79,8	82,5	76,8	80,7	
2,2	83,2	85,9	84,3	86,7	81,8	84,3	79,3	82,8	
3	84,6	87,1	85,5	87,7	83,3	85,6	81,2	84,3	
4	85,8	88,1	86,6	88,6	84,6	86,8	82,8	85,6	
5,5	87	89,2	87,7	89,6	86	88	84,5	87	
7,5	88,1	90,1	88,7	90,4	87,2	89,1	86	88,2	
11	89,4	91,2	89,8	91,4	88,7	90,3	87,7	89,6	
15	90,3	91,9	90,6	92,1	89,7	91,2	88,9	90,6	
18,5	90,9	92,4	91,2	92,6	90,4	91,7	89,7	91,2	
22	91,3	92,7	91,6	93	90,9	92,2	90,3	91,7	
30	92	93,3	92,3	93,6	91,7	92,9	91,3	92,5	
37	92,5	93,7	92,7	93,9	92,2	93,3	91,9	93	
45	92,9	94	93,1	94,2	92,7	93,7	92,4	93,4	
55	93,2	94,3	93,5	94,6	93,1	94,1	92,9	93,8	
75	93,8	94,7	94	95	93,7	94,6	93,5	94,3	
90	94,1	95	94,2	95,2	94	94,9	93,9	94,6	
110	94,3	95,2	94,5	95,4	94,3	95,1	94,2	94,9	
132	94,6	95,4	94,7	95,6	94,6	95,4	94,4	95,1	
160	94,8	95,6	94,9	95,8	94,8	95,6	94,6	95,4	
≥200	95	95,8	95,1	96	95	95,8	94,8	95,6	

# Certificates and standards

We apply the strictest quality standards, which are checked annually by official bodies. Quality assurance certification first took place in 1992. We now have certificates according to:

- **DIN EN ISO 9001:2015** for the quality management system as well as
- ATEX in accordance with 2014/34/EU for the production of motors with flameproof enclosures.



The need to preserve our environment by pushing environmentally friendly manufacturing methods, materials and chemicals in energy-saving motors and drives was recognized at an early stage, and incorporated into the products. These activities, up to and including the use of VOC-optimized paints, led to certification in accordance with:

- **DIN EN ISO 14001:2015** for the environmental management system



In order to be prepared for the universal use of the motors in the world's future markets, test certificates have been issued for the motors by various domestic and foreign certification authorities.

- **Explosion protection approvals e.g.:**
  - PTB ATEX for Europe
  - TR CU for Russia
  - TR CU for Belarus
  - TR CU for Kazakhstan
  - C C C for China
  - TestSafe for Australia
  - PTB IECEx worldwide



- **Ship classification societies e.g.:**
  - DNV Germanischer Lloyd (GL)
  - Lloyd's Register
  - Bureau Veritas



All of the motors comply with the following international norms and standards.

In addition to these guidelines, of course, numerous customer specifications from the chemical and petrochemical industries as well as the mechanical engineering area are also fulfilled.





By request, the motors can also be supplied in accordance with the recommendations of the VIK, the Verband der Industriellen Energie- und Kraftwirtschaft e.V. (Association of the Industrial Energy and Power Industry). This makes the motors ideally suited for the special operating Conditions.

E.G.: Of the basic materials industry or refineries. Motors of this type are marked VIK on the rating plate.

#### Standards

Country Title	International IEC International Electrotechnical Commission	Europe EN - CENELEC European Committee for Electrotechnical Standardization	Germany DIN/VDE German industry Standard/Association German electrical engineers
Rotating electrical machines Dimensioning and operating behavior	IEC 60034-1	EN 60034-1	DIN EN 60034-1/ VDE 0530 Teil 1
Procedure for determining the losses and efficiency of rotating electrical machines from tests	IEC 60034-2-1	EN 60034-2-1	DIN EN 60034-2-1 VDE 0530 Teil 2
Degrees of protection based on the overall design of rotating electrical machines (IP code) - Introduction	IEC 60034-5	EN 60034-5	DIN EN 60034-5/ VDE 0530 Teil 5
Classification of cooling methods (IC code)	IEC 60034-6	EN 60034-6	DIN EN 60034-6/ VDE 0530 Teil 6
Classification of types of construction, types of installation and the terminal box position (IM code)	IEC 60034-7	EN 60034-7	DIN EN 60034-7/ VDE 0530 Teil 7
Connection designations and direction of rotation	IEC 60034-8	EN 60034-8	DIN EN 60034-8/ VDE 0530 Teil 8
Noise limits	IEC 60034-9	EN 60034-9	DIN EN 60034-9/ VDE 0530 Teil 9
Starting behavior of three-phase motors with squirrel-cage rotors, except pole-changing motors	IEC 60034-12	EN 60034-12	DIN EN 60034-12/ VDE 0530 Teil 12
Mechanical vibration of certain machines with an axle height of 56 mm and higher; measurement, evaluation and limits of the vibration intensity	IEC 60034-14	EN 60034-14	DIN EN 60034-14/ VDE 0530 Teil 14
Efficiency classification of three-phase motors with squirrel-cage rotors, except pole-changing motors (IE code)	IEC 60034-30	EN 60034-30	DIN EN 60034-30/ VDE 0530 Teil 30
Balancing quality	ISO 1940	-	DIN ISO 1940
IEC standard voltages	IEC 60038	-	DIN IEC 60038
Evaluation and classifications of electrical insulations in accordance with their thermal behavior	IEC 60085	-	DIN IEC 60085
Three-phase asynchronous motors for general use with standardized dimensions and power ratings	IEC 60072-11)	EN 50347 2)	DIN EN 503472)
Potentially explosive atmosphere - Part 0: General requirements for devices	IEC 60079-0	EN 60079-0	DIN EN 60079-0 VDE 0170 Teil 1
Potentially explosive atmosphere - Part 1: Equipment protection by means of flameproof enclosure "d"	IEC 60079-1	EN 60079-1	DIN EN 60079-1 VDE 0170 Teil 5
Potentially explosive atmosphere - Part 7: Device protection by means of increased safety "e"	IEC 60079-7	EN 60079-7	DIN EN 60079-7 VDE 0170 Teil 6
Explosive atmPotentially esphere - Part 31: Equipment dust explosion protection by means of housing "t"	IEC 60079-31	IEC 60079-31	DIN EN 60079-31 VDE 0170-15-1

# Explosion protection

Ignition protection type Code letter	Building regulation	Protection idea	Applicable to type of the electric machine
Flameproof enclosure "d" 	EN 60079-1, VDE 0170 Part 5  Equipment for zone 1+2 <sup>1)</sup>	All parts which are potential ignition sources are surrounded by a flameproof enclosure whose unavoidable sealing surfaces are designed as ignition-proof gaps so that if an explosive atmosphere inside the enclosure explodes, this is not transferred to the explosive atmosphere surrounding the enclosure.	All motor types, e.g. - Squirrel cage motors, - Slip ring motors, - Collector motors.  For all operating modes S1 to S10, for difficult starting conditions and drives with controllable rotation speed, e.g. by means of a frequency inverter.
Increased safety "e" 	EN 60079-7, VDE 0170 Part 6  Equipment for zone 1+2 <sup>1)</sup>	In this case, measures must be taken to reliably prevent the occurrence of sparks, arcing and non-ermissible heating when the equipment is being operated properly and for its intended purpose.	Only squirrel-cage motors with an adapted motor protection switch. $t_E$ time condition!
Protection type "n" 	EN 60079-15, VDE 0170 Part 16 Electrical equipment for potentially explosive atmospheres.  Equipment for zone 2 <sup>1)</sup> (zone 2 - equipment)	Protection type for electrical equipment with which it is ensured that the equipment is not capable of igniting a surrounding potentially explosive atmosphere during normal operation and under certain abnormal conditions.  The usual protection methods for motors are: - non-sparking equipment "nA" which is designed to minimize the risk of arcing or sparks occurring; - vapour-proof enclosures "nR" which are designed to restrict the ingress of gas, vapours and mist.	Squirrel-cage motors with IP20 protection for enclosed spaces. For outdoor installation, IP44 protection or an IPW24 motor protection switch.  All motor types e.g. - Slip ring motors - Collector motors etc. with motor protection switches and overpressure monitoring.  Preventing the escape of operationally generated sparks. Manufacturer's information concerning these measures.
Dust protection 	EN 60079-31, VDE 0170 part 15-1  Operating equipment for zones 21 + 22 <sup>1)</sup>	This ignition protection type is based on limiting the maximum surface temperature of the enclosure and limiting dust ingress by using "dust-tight" or "dust-protected" enclosures.	All electric motors protected by enclosures with of surface temperature limitation.

Notes

1) DIN EN 60 079-14, VDE 0165 Part 1, Project planning, selection and installation of electrical systems

### Explosion protection of flameproof motors

The motors are tested and certified by PTB in accordance with the new European Directive 2014/34/EU (ATEX). They therefore comply with the latest European regulations. The directive regulates the condition of equipment and protective systems for use in potentially explosive areas, and has been applicable to all equipment placed on the market throughout Europe since June 30, 2003.

Certificates according to the IECEx scheme are also available for all motors for international applications.

The three-phase motors of the dBD, CD and BD model series are explosion-proof in ignition protection type "flameproof enclosure", in accordance with IEC 60079-1, for groups IIC or IIB and temperature classes T3 to T6.

The standard version of the motors in the CD model series corresponds to the highest group IIC and temperature class T4, which include all lower groups and temperature classes. The standard version of the BD and dBD series model correspond to group IIB and temperature class T4.

The test certificate that is issued does not contain any electrical data for the engine concerned. It confirms the explosion safety provided by the ignition-proof design of the engine. The manufacturer is solely responsible for defining the electrical data. Compliance with the temperature limits is verified by means of appropriate testing.

Based on their size, motors in temperature class T4 provide the same output as non-explosion-proof standard motors. The rated output of motors in temperature classes T5 and T6 must be adjusted with regard to the permissible enclosure temperatures.

The terminal compartment is designed with explosion protection type "Increased safety" (motor designation Ex de) as standard. In order to adapt to the different installation methods in the individual countries, delivery with a terminal compartment with "flameproof enclosure" ignition protection type is also possible (motor designation Ex d). For this purpose, the terminal compartment is designed in the same explosion group as the motor.

In both versions, the motor compartment and terminal compartment are separated from each other in an explosion-proof manner. The winding leads are led into the terminal compartment via flameproof cable leadthroughs.

Due to their high degree of explosion protection, our motors can be used in all potentially explosive locations in zones 1 and 2 under all operating conditions.

They can be used in potentially explosive atmospheres where, in accordance with the local and operational conditions, gases and vapours that form potentially explosive mixtures with air can accumulate in hazardous quantities. Due to their design, the motors are protected against water, electrical, chemical, thermal and mechanical influences in such a way that explosion protection is maintained during use for their intended purpose.

Marking on the motor, e.g.:

 0044  II 2G Ex db eb IIC T4 Gb

# Explosion protection

Ignition protection types and categories of electrical machines

12

Protection against dust ingress EN 60079-31

Application	Protection level	conductive dust IIIC	Device group	
			non-conductive dust IIIB	Lint IIIA
Zone 20	ta	IP6X	IP6X	IP6X
Zone 21	tb	IP6X	IP6X	IP5X
Zone 22	tc	IP6X	IP5X	IP5X

## Dust explosion protection

The dust explosion protected motors are certified by the PTB in accordance with the new directive 2014/34/EU and are compliant with DIN EN 60079-31.

An essential feature of dust explosion protection is the IP protection class. Depending on the ambient conditions, different demands are made on the dust-tightness of the motor. It is also important for dust explosion protection to limit the surface temperature of the motors to a value that is below the ignition and glow temperature of the dust that occurs.

The user must determine the category, the protection level and the maximum permissible surface temperature according to the frequency and probability of occurrence and the type of dust.

Marking on the motor:



The motors can also be designed to be dust or gas explosion proof at the same time.

## Information concerning the introduction of directive 2014/34/EU (ATEX)

The regulations for the construction and operation of electrical equipment in potentially explosive atmospheres were defined in the European Directive 76/117/EEC and various supplements for many years. The transition to the two new directives, 2014/34/EU (ATEX) for manufacturers and 99/92/EC (ATEX) for operators, represents a fundamental reorganization of the European regulatory framework.

Directive 2014/34/EU (formerly 94/9/EC) harmonises the national legislation for the quality requirements of devices and protective systems, which previously differed. This will achieve the objectives of reducing trade barriers and standardising the basic safety aspects within the EC. In specialist circles, the abbreviation "ATEX" (letter abbreviation of the French title of the directive) is often used.

The installation requirements for operation in potentially explosive atmospheres are regulated by directive 99/92/EC (ATEX).

The directives were implemented into German law in 1996 in the same two-part structure via the Equipment Safety Act with the Explosion Protection Ordinance (ExVO) for ATEX and by the Industrial Safety and Health Ordinance (BetrSichV) for ATEX. A whole series of old regulations, including the ElexV, therefore ceased to be valid.

An essential feature of ATEX is an additional classification and marking of equipment and protective systems into categories and equipment protection levels. These categories and protection levels were defined based on the zoning of the operating sites that

takes place due to the probability of occurrence of potentially explosive atmospheres. This makes direct assignment of the operating resources for use in the individual zones of the operating facilities easier.

The external marking of the motors that comply with the new directive is the CE mark, and the indication of the device group and category, e.g. "II 2G" and the device protection level e.g. "b" for zone 1 devices in the gas area on the nameplate. The prerequisites for affixing the CE mark and issuing the declaration of conformity, which comes from the manufacturer are:

The manufacturer must provide evidence of a certified quality assurance system in accordance with ISO 9001 with an additional certificate for the quality assurance of the production of explosion-proof equipment in accordance with ATEX.

An EU type examination certificate issued by a recognized inspection body must be available. (Not required for category 3 devices)

Until the end of the transition period (June 30, 2003), manufacturers and operators had the option of proceeding in accordance with both the old and the new law.

#### Permissible temperatures of electrical equipment

DIN EN 60079, VDE 0170 Explosion group IIA; IIB; IIC		
Ignition temperature of the medium to the limit temperature	Temperature class	Permissible surface temperature of the equipment including 40 °C (limit temperature) with individual testing of the ambient temperature
above 450 °C	T1	450 °C
300–450 °C	T2	300 °C
200–300 °C	T3	200 °C
135–200 °C	T4	135 °C
100–135 °C	T5	100 °C
85–100 °C	T6	85 °C

Since July 1, 2003, all new products that are placed on the market must comply with the new ATEX directive.

Spare parts for all versions are available by request.

Existing systems may continue to be operated, but since 30.06.2006 they must fulfil the minimum requirements of ATEX.

Device group	Device category	Device protection level	Zoning	Definition in accordance with BetrSichV	Certification obligation
<b>for flammable gases, vapours and mists</b>					
II	1G*	a	0	Zone 0 includes areas in which a potentially explosive atmosphere consisting of a mixture of air and gases, vapours or mists is present continuously, for long periods or frequently.	yes
II	2G	b	1	Zone 1 includes areas in which a potentially explosive atmosphere consisting of gases, vapours or mists is likely to occur occasionally.	yes
II	3G	c	2	Zone 2 includes areas in which a potentially explosive atmosphere consisting of gases, mists or vapours is not expected to occur, but if it does occur, it is likely to only occur infrequently and for a short period of time.	no
<b>for combustible dusts</b>					
III	1D*	a	20	Zone 20 includes areas in which a potentially explosive atmosphere consisting of dust/air mixtures is present continuously, for long periods or frequently.	yes
III	2D	b	21	Zone 21 includes areas in which a potentially explosive atmosphere consisting of dust/air mixtures is likely to occur occasionally.	yes
III	3D	c	22	Zone 22 includes areas in which a potentially explosive atmosphere caused by no whirled-up dust is not expected to occur, but if it does occur, it is likely to occur only very rarely and for a short period of time.	no

\* not usual for electric motors

# Explosion protection

## Ignition protection types and categories of electrical machines

14

	Group	Temperature classes					
		T1	T2	T3	T4	T5	T6
Firedamp protection	I	Methane (Firedamp)	-	-	-	-	-
Explosion protection	IIA	Acetone, ammonia, Benzene, acetic acid Ethan, Ethyl acetate, ethyl chloride Carbon oxide Methane (Firedamp) Methanol, methyl chloride, propane, Toluene	l-amyl acetate, n-Butane, n-Butyl alcohol Cyclohexanone Acetic acid anhydride, Natural gas, Liquid gas	Hexane, benzines, Diesel fuels, Jet fuels, Heating oil, crude oil1)	Acetate dehyd, Ether	-	-
	IIB	Coke oven gas, Water gas (carburized)	Butadiene-1,3 Ethyl alcohol, Ethylene, Ethylene oxide	Petroleum <sup>1)</sup> , isoprene, Hydrogen hydrogen	Ethyl ether	-	-
	IIC	Hydrogen	Acetylene	-	-	-	Carbon disulphide

Note

1) Depending on the composition

Flammable gases and vapours are classified into groups and temperature classes, which are identified by abbreviated symbols consisting of numbers and letters.

The letters from IIA to IIC define the group which determines the formation of the flameproof gap in the machines.

The letter T with the assignment of digits 1-6 indicates the temperature class, which defines the permissible surface temperature of the machine.

Extracts of the groups/temperature classes assigned for the gases and vapours are summarised in the table shown above.

Note concerning the table:

More examples can be found in the publication "Sicherheits- technische Kennzahlen brennbarer Gase und Dämpfe" (Technical safety codes for flammable gases and vapours) by Nabert/Schön, Deutscher Eichverlag, Berlin.

## List of test certificates

Size/ Series	CD ... <sup>1)</sup>	BD ... <sup>2)</sup>	BD ... B(R) <sup>3)</sup>	BD ... Y3B) <sup>4)</sup>	CEIGL ... <sup>5)</sup>	CM ... <sup>8)</sup>
63	13 ATEX 1012 X IECEx PTB 12.0036 X	2020312301002337	17 ATEX 1007 X			
71	13 ATEX 1012 X IECEx PTB 12.0036 X	2020312301002337	17 ATEX 1007 X			
71Y	14 ATEX 1001 X IECEx PTB 14.0001 X	2020312301002336	17 ATEX 1008 X			
80	14 ATEX 1001 X IECEx PTB 14.0001 X	2020312301002336	17 ATEX 1008 X	08 ATEX 1110 X	21 ATEX 1006 X	08 ATEX 1111 X 19 ATEX 1002 X IECEx PTB 19.0022 X
90	14 ATEX 1001 X IECEx PTB 14.0001 X		17 ATEX 1008 X	08 ATEX 1110 X	21 ATEX 1006 X	08 ATEX 1111 X 19 ATEX 1002 X IECEx PTB 19.0022 X
90 Y*_2	14 ATEX 1010 X IECEx PTB 14.0014 X	2020312301002336	17 ATEX 1009 X		21 ATEX 1006 X	
100	14 ATEX 1010 X IECEx PTB 14.0014 X	2020312301002336	17 ATEX 1009 X	08 ATEX 1110 X		08 ATEX 1111 X 17 ATEX 1001 X IECEx PTB 16.0003 X
112	14 ATEX 1010 X IECEx PTB 14.0014 X	2020312301002336	17 ATEX 1009 X	08 ATEX 1110 X		08 ATEX 1111 X 17 ATEX 1001 X IECEx PTB 16.0003 X
112Y	15 ATEX 1005 X IECEx PTB 15.0011 X	2020312301002336	17 ATEX 1010 X			
132	15 ATEX 1005 X IECEx PTB 15.0011 X	2020312301002335	17 ATEX 1010 X	08 ATEX 1110 X		08 ATEX 1111 X 14 ATEX 1013 X IECEx PTB 14.0026 X
160	16 ATEX 1022 X IECEx PTB 16.0040 X	2020312301002335	09 ATEX 1011 X			15 ATEX 1012 X IECEx PTB 15.0030 X
180	08 ATEX 1056 X IECEx PTB 06.0022	2020312301002334	09 ATEX 1012 X			
200	08 ATEX 1081 X IECEx PTB 06.0023	2020312301002334	09 ATEX 1013 X			
225	08 ATEX 1087 X IECEx PTB 06.0009	2020312301002333	09 ATEX 1011 X			
250	08 ATEX 1087 X IECEx PTB 06.0009	2020312301002333	09 ATEX 1011 X			
280	08 ATEX 1087 X IECEx PTB 06.0009	2020312301002333	09 ATEX 1011 X			
315	08 ATEX 1087 X IECEx PTB 06.0009	2020312301002332	09 ATEX 1011 X			
355	08 ATEX 1082 X IECEx PTB 06.0024	2020312301002331	09 ATEX 1014 X			
400	08 ATEX 1083 X IECEx PTB 06.0036	2020312301002331	09 ATEX 1015 X			
450	08 ATEX 1085 X IECEx PTB 06.0037	2020312301002331	09 ATEX 1006 X			
500 <sup>5)</sup>			09 ATEX 1008 X			

## Notes concerning ATEX marking

- Standard series Group IIC: II 2G Ex db eb IIC T3...T6 Gb or Ex db IIC T3...T6 Gb and/or II 2D Ex tb IIIC T120 °C Db or Ex de IIC T3...T6 Gb or Ex de IIC T3...T6 Gb or Ex tD A21 IP6X T85 °C ...T200 °C
- Standard series Group IIB: II 2G Ex db eb IIB T3...T6 Gb or Ex db IIB T3...T6 Gb and/or II 2D Ex tb IIIB T120 °C Db
- Motors with built-in brake/encoder group IIB incl. hydrogen: II 2G Ex de IIB+H2 T3...T6 Gb or Ex d IIB+H2 T3...T6 Gb and/or III 2D Ex tb IIIB T120 °C Db
- Motors with built-in brake/encoder group IIB incl. hydrogen: II 2G Ex db eb IIB+H2 T4...T6 Gb or Ex d IIB+H2 T4...T6 Gb and/or III 2D Ex tb IIIB T120 °C Db
- Inverter box of the compact drive
- Type dBD
- IECEx certification: Dust marking only possible with size 63-160+280
- Mounting brake type CM..

### Test certificate for ignition protection type "flameproof enclosure", temperature class T3...T6 and dust protection by housing

Type examination certificates according to Directive 2014/34/EU (ATEX) and certificates according to the IECEx scheme are available for the CD..., BD..., dBD... and BD...B/R, EU (EC) series. These certificates, which are issued up to temperature class T6 for three-phase asynchronous motors of ignition protection type "d", do not contain any rated data for the motor type concerned. They confirm the explosion safety due to the tested ignition-proof and dust-tight design of the motor. The following design variants of the rated data are also certified, which must be confirmed by the manufacturer by mentioning them on the motor rating plate:

- Rated voltages up to 1000 V.  
From size 355 up to 6600 V.
- Rated frequency below or above 50 Hz, e.g. 60 Hz.
- Pole-changing motors, e.g. 4/2 or 6/4 pol.
- Ambient temperatures -55 °C to 60 °C.
- Less than -20 °C, also without heating.
- Installation altitudes higher than 1000 m above sea level.
- Installation of TF (thermistors in accordance with DIN 44081) as the sole protection against non-permissible heating with operating mode S1, S2, S3, S4, S5, S6, S7, S8, S9 or S10. The sole protection is achieved only by a combination of TF and tripping devices with test mark II (2)G.
- With TF installed as the sole protection, power can be supplied from any variable frequency drive for motor speed control.
- Temperature classes T3 to T6.
- Dust protection II 2D for zone 21 and II 3D for zone 22.

# Type code

16

Type code

Example:

C			D			112			M			-			2			S			
1	2	3	4	5	6	7	8	9	10	11	12	13	14	15	16	17	18	19	20	21	...

Number	Feature	Characteristic	Meaning
1	Explosion (optional)	d	Flameproof enclosure
		B	B-series
		C	C-series
2	Explosion	C	Flameproof enclosure IIC
		CE	Flameproof enclosure IIC + increased safety
		B	Flameproof enclosure IIB
		e (E)	Increased safety
		n	Non-sparking design
3	Motor type	AR	Connection room
		D	Three-phase AC motor, Nordenham production site
		DP	Three-phase AC motor, Tamel production site, Poland
		FG	Field frequency inverter housing
		IGL	Lenze integrated inverter housing
		M	Mounting brake type ATB
4	Size	- 63	Size 63
		- 71	etc.
		...	
5	Package	K, S	Short package length
		M	Medium package length
		L	Long package length
		L1	etc.
-	Hyphen		
6	Number of	4	4-pole
		8/4	8/4-pole
		12/8/4	12/8/4 pole
		...	
7	Version	<i>The order must be adhered to as follows when naming the motors:</i>	
		X	Increased performance
		Y	High efficiency in accordance with the Australian MEPS standard
		Y2	High efficiency IE2 in accordance with EN 60034-30
		Y2.1	High efficiency IE2 in accordance with EN 60034-30 (version .1)
		Y2.7	High efficiency IE2 in accordance with EN 60034-30, max 7-fold starting current
		Y3	Premium efficiency IE3 in accordance with EN 60034-30
		Y3.1	High efficiency IE3 in accordance with EN 60034-30 (version .1)
		Y4P	Premium efficiency IE4 in accordance with EN 60034-30 (permanent magnet motor)
		YT	High efficiency in accordance with the Australian HEPS standard
		H	High voltage motor
		A	Axial fan, depending on the direction of rotation, noise class 2
		AR	Axial fan reduced, noise class 3
		W	Water cooling, noise class 4
		B	Built-in brake (spring pressure principle)
		D	Terminal box - flameproof
		E	Terminal box - increased safety
		F	Externally driven axial fan
		G	Encoder attachment
		I	Integrated inverter (compact drive)
		IT	Integrated inverter (compact drive) for IT network
		K	Direct cable entry
		N	Only in conjunction with mounted brake type CM - NS closed
		O	Without ventilation
		R	Built-in encoder (resolver)
		S	Special brake, type Kendrion (NS attachment)
		SM	Special brake, type ATB CM (DS attachment)
SMN	Special brake, type ATB CM (NS attachment)		
SV	Special brake, type VIS (DS attachment)		
SVN	Special brake, type VIS (NS attachment)		
U	Peak voltage strength 2.15		
0, 1, 2, ...	Design status		

Individual items may be omitted if not required.

Up to size 355 - all numbers of poles - the bearing arrangement of the motors is designed in such a way that they can be used as follows without additional measures on the motor:

- IM B3 as IM B6, IM B7, IM B8, IM V5\*, IM V6\*
- IM B5 as IM V1\*, IM V3\*
- IM B35 as IM V15\*, IM V35\*
- IM B14 as IM V18, IM V19



Up to size 355 - all numbers of poles - the bearing arrangement of the motors is designed in such a way that they can be used as follows without additional measures on the motor:

Exception: Vertical designs marked with \* must be equipped with protection against dripping water and vertical falling in of foreign bodies

High-voltage motors from size 400 are available in IM B3, IM B35 and IM V1.

Available types in accordance with  
DIN IEC 60034 part 7

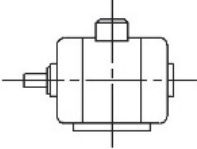
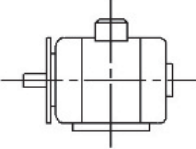
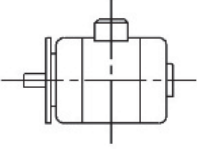
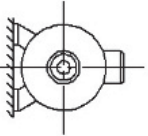
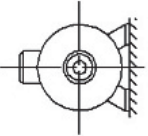
other types by request

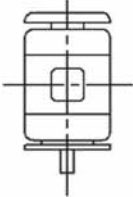
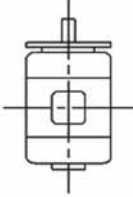
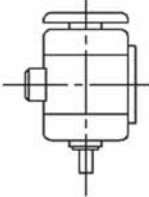
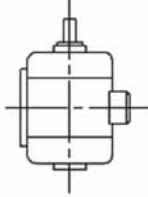
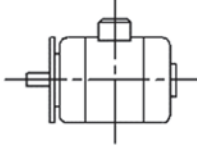
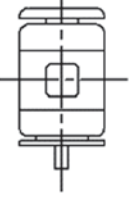
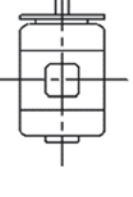
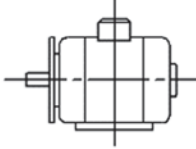
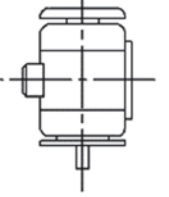
					
IEC code I IEC code II Explanation	IM B3 IM 1001 Foot mounting, feet at bottom	IM B35 IM 2001 Foot mounting, feet at bottom, with additional flange mounting, with access from housing side	IM B5 IM 3001 Flanged end shield at drive side, with access from housing side	IM B6 IM 1051 Foot mounting, feet on left (seen from drive side)	IM B7 IM 1061 Foot mounting, feet on right (viewed from drive side)
					
IEC code I IEC code II Explanation	IM B8 IM 1071 Foot mounting, feet on top	IM V1 IM 3011 Flange mounting at drive side of flange, with access from housing side, drive side at bottom	IM V3 IM 3031 Flange mounting at drive side of flange, with access from housing side, drive side on top	IM V5 IM 1011 Foot mounting, drive side at bottom	IM V6 IM 1031 Foot mounting, drive side on top
					
IEC code I IEC code II Explanation	IM B14 IM 3601 Flange mounting at drive side of flange, no access from housing side	IM V18 IM 3611 Flange mounting outdrive side of flange, no access from housing side, drive side at bottom	IM V19 IM 3631 Flange mounting at drive side of flange, no access from housing side, drive side on top	IM B34 IM 2101 Foot installation, feet at bottom, with additional flange attachment at drive side of flange, no access from housing side	IN V15 / IN V35 IN 2011 / IN 2031 Foot mounting, with additional flange mounting at drive side of flange, drive side at bottom / on top, with access from housing side

# Materials, signage

for housing, end shields, terminal compartment, ventilation

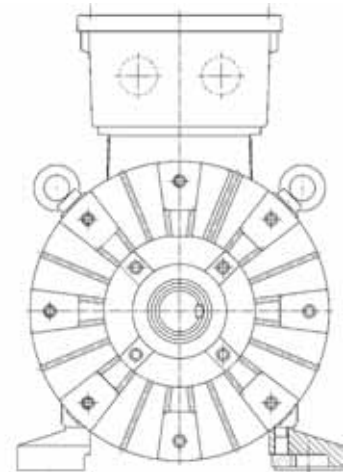
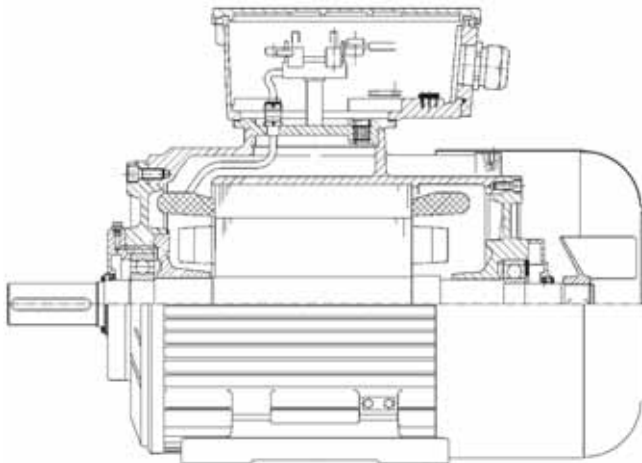

Materials for housing, end shields, terminal compartment, ventilation

Size	Housing version		End shield	Terminal compartment		Fan guard	Radial fan		Axial fan
	Housing	Feet		Ex e	Ex d		2-pole	4, 6, 8-pole	
63	Grey cast iron	Steel	Grey cast iron	Cast iron, screwed on	Cast iron, screwed on	Sheet steel	Plastic <sup>1)</sup>	Plastic <sup>1)</sup>	Plastic
71									
80									
90									
100									
112									
132									
160									
180									
200									
225									
250									
280									
315									
355									
400	Steel, welded	Steel, welded	Steel, welded	Steel, welded	Steel, welded	Steel, welded	Steel, welded	Steel, welded	Steel, welded
450									

**Note**

1) For special operating conditions, e.g. low temperatures, fans in cast aluminum alloy or steel can also be supplied for the size range from 63 to 160.

2) Steel fan by request.

**Signage**

The rating plate and the test plate are combined into one plate and attached to the housing. There is a duplicate in the Ex e terminal compartment cover for motors, in accordance with the VIK regulation.

The plates are made from stainless steel (material 1.4300).

# Installation at normal, elevated and low temperatures

As standard, the motors are suitable for installation outdoors, in dusty and humid atmospheres (industrial climate) at ambient temperatures from -20 °C to +40 °C. Special versions are available for an increased ambient temperature range of -55 °C to +60°C. In these cases, an appropriate marking is made on the test plate.

At ambient temperatures above +30 °C, the motors must not be placed in direct sunlight. For this purpose, the motors can be equipped with a sunshield.

At ambient temperatures above +40 °C, the power may be reduced depending on the version of the motor (see page 53).

For temperatures lower than -20 °C, the motors are supplied in two versions, with or without stationary heating, according to the tables opposite.

For versions with stationary heating, the heating must be used to prevent the motor temperature from dropping below -20 °C (see page 50). Heating takes place via the motor winding.

Motors for installation on board ships and in offshore areas can be designed in accordance with the regulations of the relevant classification societies. To ensure safe operation when they are used on the top deck, the motors are equipped with a number of additional structural measures (see page 37).

Type approval certificates from various ship classification societies, e.g. Germanischer Lloyd, are available for motors of this type.

Use at low temperatures with stationary heating via the motor winding

Component	-40 °C
Marking	normal
Stationary heating	required
Fan	special
Cable entry	special
Closing plug	special
Temperature	special

Use at low temperatures without stationary heating via the motor winding

Component	-40 °C	-55 °C
Marking	special	special
Component routine	increased	increased
Steel components	special	special
Fastening screws	special	special
Fan	special	special
Eyebolts	special	special
Shaft seal	normal	special
Bearing grease	normal	special
Bearing	normal	special
Cable entry	special	special
Closing plug	special	special
Paint	normal	special

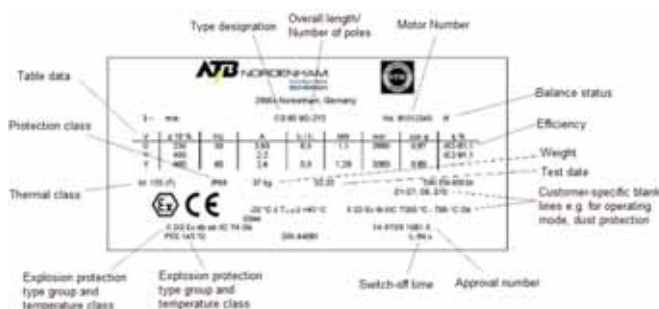

# Paint, Protection types, Tropicalized version

20

Paint systems	Standard paint	Standard paint Special colors in accordance with RAL	Special interior painting	Acid protection + Inshore	Offshore standard (ST)	Offshore special (SP)	Offshore in acc. with Norsok (NO)
Protective effect in accordance with ISO 12944	C2 medium C3 low	C2 medium C3 low	C2 medium	C3 high C4 low	C5-M low C4 medium	C5-M medium C4 high	C5-M high
Pretreatment of the parts	all surfaces clean and grease-free, sandblasted in accordance with SA 2.5 ISO 8501-1						
1. Primer	Cast surfaces				/	Two-component zinc epoxy paint min. 70 µm	Two-component zinc-epoxy primer with high zinc content, min. 75 µm
	Single-component alkyd resin primer, min. 20 µm						
	Steel surfaces						
	Single-component product based on polyvinyl butyral, min. 25 µm						
2. Primer	/		Two-component Polyacrylic based low solvent,	Two-component epoxy primer,	min. 120 µm	Two-component polyacrylic based, low solvent content,	Two-component epoxy primer/ top coat with high solid content,
	/		min. 60 µm				
Top coat	Two-component acrylic resin single-coat paint, min. 60 µm	Two-component acrylic resin single-coat paint, min. 60 µm	/	Two-component acrylic resin single-coat paint min. 80 µm			Two-component acrylic top coat min. 60 µm
Paint thickness	min. 80 µm	min. 80 µm	min. 80 µm	min. 160 µm	min. 200 µm	min. 210 µm	min. 310 µm
Colour	RAL 5009	RAL		RAL 7031, 7032 ...			RAL 7038
Mechanical strength	non-abrasive, elastic, scratch-resistant, impact-resistant						
Corrosion resistance	resistant to water, water vapour and salt water				high resistance to water, water vapour and salt water		
Chemical resistance	resistant to solvents, chemicals, synthetic coolants, hydraulic fluids, cleaning agents				high resistance to solvents, chemicals, synthetic coolants, hydraulic fluids, cleaning agents		
Temperature range	-40 °C to +130 °C		-55 °C to +130 °C				

Note: Other coatings, also isocyanate-free and certified in accordance with Frosio Level III, are available by request.

## Available protection classes in accordance with DIN IEC 60034-5

Temperature class	T4	T4	T6
Size	RT ≤ 40 °C	RT > 40 ≤ 60 °C	RT ≤ 40 °C
63–450	IP55	IP55 <sup>2)</sup>	IP55
63–450	IP56	-	-
63–355 <sup>3)</sup>	IP66 <sup>1)</sup>	-	-
63–315 <sup>4)</sup>	IP55	IP55 <sup>2)</sup>	-

Notes:

- 1) IP66 not provided for in DIN EN 60034 Part 5
- 2) Power adjustment required
- 3) Bigger motors by request
- 4) Series CD...X

## Tropicalized design

For use under the special climatic influences of the tropics, we recommend the following version:

- Protection class IP56
- Stainless steel screws
- Double stator winding impregnation
- Special interior painting
- Inshore painting

This provides optimum protection against moisture and mould infestation.

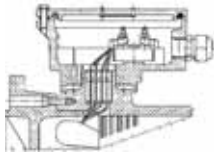

Size 63-112

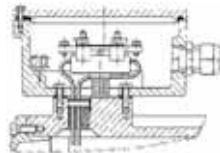

Size 132-160

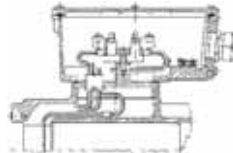

Size 180-280 (450) from size 315 with bolt leadthrough

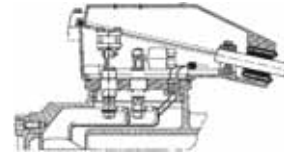

Size 250-315 (450)  
Size 250 and 280 with terminal board like size 180-280

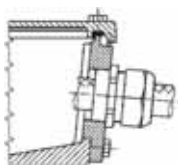

Version 1  
Cable entry in accordance with EN 60079-7 (stuffing box gland) for introducing fixed cables

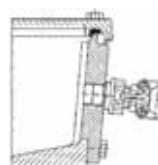

Version 3  
Cable entry gland in accordance with EN 600 Version 3  
Cable entry gland in accordance with EN 600 Version 3

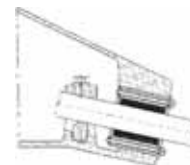

Version 9  
Divided terminal box with strain relief clamp inside, cable entry in accordance with EN 60079-7

## Protection class

The terminal compartments comply with ignition protection type "Increased safety" Ex e II for gas explosion protection in accordance with EN 60079-7 and protection type IP56 in accordance with DIN EN 60034 Part 5 or protection typw Ex d IIC in accordance with EN 60079-1.

For dust explosion protection, they are designed in protection type IP 66 in accordance with EN 60079-31. With ignition protection type Ex e II and dust explosion protection, they are equipped with a cable entry which and an oil-resistant cover seal which are correspond to the protection type. The cover screws are protected against corrosion and captive (not with high voltage). Cable entries for ignition protection type Ex d IIC available by request.

## Position and twistability

The terminal compartments are located on top of the motors as standard. They can also be located at the side by request. From size 63 and above they can each be rotated by 4 x 90 degrees to allow connection from all directions.

A universal housing is also available for sizes 80 to 180 so that the terminal compartment can also be converted at a later date from top to side, for example. From size 132 and above, this can be done without turning the leadthrough plate. Additionally mounted auxiliary terminal compartments may restrict the rotation of the main terminal compartment.

## Cable leadthroughs and connecting terminals

The winding leads are routed into the terminal compartment via flameproof cable leadthroughs.

With low-voltage motors, multiple or single leadthroughs are used for AC voltage up to at least 690 V. Special versions for 1100 V are possible (additional price). High-voltage motors are provided with individual leadthroughs in accordance with the rated voltage. Sizes 315-450 have terminals for cable-shoe-less connection placed directly on the leadthrough connectors.

## Terminal compartments, standard version Ex e II

The terminal compartments of the low-voltage motors are provided with metric threads, assigned in accordance with DIN 42 925 with cable entries in accordance with DIN EN 50 262, and certified in accordance with DIN EN 60079-7. From size 180, they are equipped with a screw-on plate. Longitudinally divided terminal compartments are also available for sizes 250 and larger.

An additional terminal compartment for thermal monitoring or stationary heating is available by request from size 80. It is screwed to the engine terminal compartment. Additional terminal compartments with two terminals are possible up to size 112, and from size 132 four and more terminals can be implemented. For sizes 355 to 450, it is fitted to the housing.

Terminal compartments for high-voltage motors correspond to DIN 42 962. The neutral point is implemented in a second terminal compartment by request. The boxes comply with protection type "Increased safety" Ex e II in accordance with EN 60079-7 and are supplied in version 9. The different cable entry parts (additional price) and the assignment of the threads to the cable entry parts can be found in the table on page 22.

# Terminal compartments

22

## Entries of the mains supply lines for Ex e terminal compartments

Version	Size	63	71	80	90	100	112	132	160	180	200	225	250	280	315	355	400-450	High Voltage
1	Thread version	M25 x1.5				M32 x1.5			M40 x1.5	M50 x1.5	M63 x1.5		M75x1,5		M63 x1.5			
	for cable outer Ø mm	8-17.5				14-21			19-28	24-35	29-48		50-65		29-48			
3	Thread version	M25 x1.5				M32 x1.5			M40 x1.5	M50 x1.5	M63 x1.5		by request		by request			
	for cable outer Ø mm	11-16				15-20			19-27	28-34	38-46		by request		by request			
9	for cable outer Ø mm	unavailable										1x Ø 48-70 2x Ø 24-54		1x Ø 48-70 2x Ø 48-70		1x Ø 24-54		

### Notes

From size 132 in pole-changing version or  $\Delta$ start-up 2 mains entries each.

For thermal monitoring in all versions, 1x additional cable entry M25 x1.5.

For heating in all versions, 1x additional cable entry M25 x1.5.

For rated currents greater than 400 A, the terminal compartments have with 2 mains entries.

= Normal version

## Clampable cross sections with Ex e for low voltage

Size	Rated cross-section max. mm <sup>2</sup>	Rated current max. [A]	Terminal type	Number of terminals	Connection thread
63-112	4	25	U-clamp <sup>2)</sup>	6	M5
132, 160	10	63	U-clamp <sup>2)</sup>	6	M6
180-225	70	100	Strap clamp <sup>2)</sup>	6	M8
250-280	120	250	Strap clamp <sup>2)</sup>	6	M12
315 S, M, L1	150	315 <sup>1)</sup>	Round clamp <sup>2)</sup>	6	M12
315 L2, L3-450	300	400 <sup>1)</sup>	Round clamp <sup>2)</sup>	6	M16
355-450	400	630 <sup>1)</sup>	Universal terminal <sup>3)</sup>	6	M20

### Note

1) Material: Cu

2) Connection with cable shoe without terminal possible

3) suitable for connection with cable lug

## Terminal compartment Ex d IIC

The terminal compartments correspond with protection type "Ex d IIC" in accordance with EN 60079-1. In the standard version, the terminal compartments are provided with a threaded hole in accordance with DIN-ISO-13. Different thread versions such as NPT can also be supplied by request. The thread dimensions must be specified when ordering.

**Note:** Cable entry parts in enclosures with type of protection Ex d IIC must also correspond to EN 60079-1 and be certified.

These parts are not included in the scope of delivery. Flameproof terminal compartments are also available for high voltage motors.

## Entry thread for Ex d terminal compartments for low-voltage motors

Size	63	71	80	90	100	112	132	160	180	200	225	250	280	315	355-450
Thread version ISO-DIN 13	M25 x1,5		M32 x1,5			M40 x1,5	M50 x 1,5	M63 x1,5		M75 x1.5					
Nema-Version NPT	3/4"		1"			1 1/4"	1 1/2"	2"		3"					

## 3 ends 400V<sup>1)</sup>, 6 ends 400/690V<sup>1)</sup> - cableNSSHöu<sup>1)</sup>

Size	Number of poles	3 winding leads + PE - Direct connection		6 Winding leads + PE - Y / Δ Start-up - pole-changing	
		without temperature monitoring	with temperature monitoring	without temperature monitoring	with temperature monitoring
63	2-4				
71	2-8	1 cable	1 cable	1 cable	1 cable
80	2-8	4 cores	7 cores	7 cores	10 cores
90	2-8	Cross section 1.5 mm <sup>2</sup>	Cross section 1.5 mm <sup>2</sup>	Cross section 1.5 mm <sup>2</sup>	Cross section 1.5 mm <sup>2</sup>
100	2-8	max. 20 A	max. 20 A	max. 20 A	max. 20 A
112	2-8	Outer Ø approx. 13 mm	Outer Ø approx. 17.5 mm	Outer Ø approx. 17.5 mm	Outer Ø approx. 19.5 mm
132	2-8	1 cable	2nd additional cable with 4 cores	2 cables	
160	2-8	4 cores	4 cores each	4 cores each	
		Cross section 4 mm <sup>2</sup>	Cross section 1.5 mm <sup>2</sup>	Cross section 6 mm <sup>2</sup>	
		max. 36 A	max. 20 A	max. 36 A	
		Outer Ø approx. 18 mm	Outer Ø approx. 13 mm	Outer Ø approx. 18.8 mm	
180	2-8				
200	L1-2	1 cable			3rd additional cable with 4 cores
	4-8	4 cores			Cross section 1.5 mm <sup>2</sup>
		Cross section 10 mm <sup>2</sup>			max. 20 A
		max. 265 A			Outer Ø approx. 13 mm
		Outer Ø approx. 23 mm			
	L2-2				
225	2-4	1 cable		2 cables	
		4 cores		4 cores each	
		Cross section 16 mm <sup>2</sup>		Cross section 16 mm <sup>2</sup>	
		max. 87 A		max. 87 A	
		Outer Ø approx. 28 mm		Outer Ø approx. 28 mm	
250	2-4				
		for 500 V only			
		1 cable			
		4 cores			
		Cross section 16 mm <sup>2</sup>			
		max. 87 A			
		Outer Ø approx. 28 mm			
280	2-8				
		for 690 V only			

### Notes:

Cable included in scope of delivery. Cable length 1.5 m. Special lengths possible by request.

1) Standard power 50 Hz. In the event of deviating data, the permissible currents of the cables must be observed.

Other cable types such as Ölflex or MPRXCX available by request.

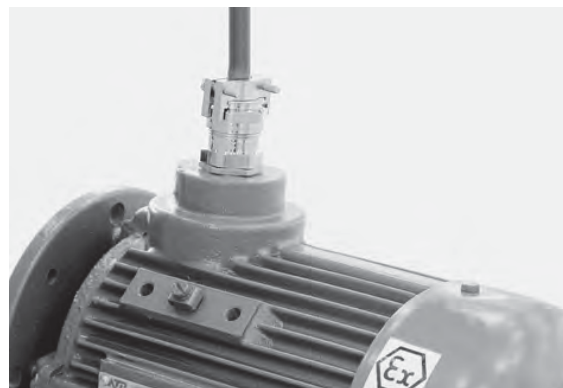

Motor with direct cable entry

## Bearing seal

The external bearing sealing of the motors takes place using a radial or axial seal. Vertical designs with a shaft pointing upwards can be supplied with a combined radial and axial seal by request. This prevents water from entering the bearing housing along the shaft. The seals have good abrasion resistance and temperature resistance. They are resistant to mineral oils, salt solutions and diluted acids. Seals for media which have not been mentioned by request.

## Lubrication

The bearings of the motors up to size 280 have lifetime lubrication. The grease filling with polyurea grease that is required for the deep groove ball bearing that is sealed at both sides has already been provided by the bearing manufacturer. Measures have therefore been taken to achieve a maintenance-free run time in accordance with the top table on page 31.

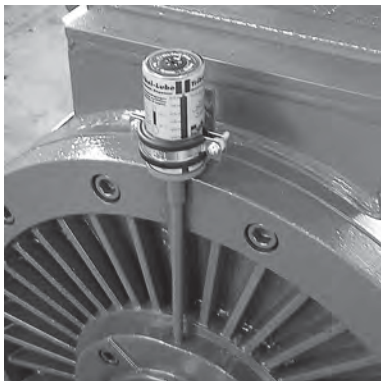

Long-term dispenser

## Relubrication and relubrication intervals

Motors from size 315 are equipped with relubrication devices with a grease distributor. Grease relubrication devices are also provided for motors of size 225 and bigger which have to be equipped with roller bearings for load reasons.

Bearing arrangements with a relubrication device receive a filling consisting of lithium saponified grease. The relubrication times can be found in the table on page 31.

In the case of a vertical design (V design), the relubrication times must be halved.

Relubrication must be carried out with the same type of grease, i.e. the same saponification component and the same consistency. For this purpose, ATB uses a lithium saponified rolling bearing grease with a

drip point > 185 °C (e.g. Mobil Unirex N 3), see also information plate on motor.

The collection space in the bearing cover for the escaping used grease is designed to be large enough to accommodate the quantity of grease that will be produced during the nominal service life. Flat grease nipples to DIN 3404 with an M10x1 thread are used as grease nipples.

It is possible to use long-term dispensers for relubrication. Depending on the application, a maintenance-free period of up to 12 months can be achieved. The dispensers are designed with protection type II 2G Ex ib IIC T6.

## Nominal service life

The calculated service life is more than 50,000 operating hours in pure coupling operation.

The max. permissible radial and axial loads are specified in the tables on pages 27 to 29. A roller bearing service life of

20,000 hrs was taken as the basis for the calculation.

Drives with higher radial loads, such as belt drives, can be equipped with roller bearings at additional cost, see page 29. It should be noted that the specified minimum radial load must always be present to ensure that proper rolling takes place in the bearing. Special solutions are available by request for higher axial loads, such as the ones which may occur with helical gearing.

**IE1 version**

Series CD ..	Number of poles	DS bearing, all types		NS bearing all designs (floating bearing)
		Standard (fixed bearing)	reinforced bearing <sup>2)</sup>	
63	2, 4	6202 2Z	-	6004 2Z
71	2, 4, 6, 8	6202 2Z	-	6004 2Z
80	2, 4, 6, 8	6204 2Z	-	6204 2Z
90	2, 4, 6, 8	6205 2Z	-	6205 2Z
100	2, 4, 6, 8	6206 2Z C3	-	6206 2Z C3
112	2, 4, 6, 8	6306 2Z C3	-	6206 2Z C3
132	2, 4, 6, 8	6308 2Z C3	-	6308 2Z C3
160	2, 4, 6, 8	6309 2Z C3	-	6309 2Z C3
180	2, 4, 6, 8	6310 2Z C3	-	6310 2Z C3
200	2, 4, 6, 8	6312 2Z C3	-	6312 2Z C3
225	2, 4, 6, 8	6313 2Z C3	-	6313 2Z C3
250	2, 4, 6, 8	6315 2Z C3	-	6313 2Z C3
280	2, 4, 6, 8	6316 2Z C3	-	6315 2Z C3
315	2	6316 C3	-	6316 C3
	4, 6, 8	6318 C3	-	6316 C3
355	2	6318 C3	-	6318 C3
	4, 6, 8	6320 C3	-	6318 C3
			<b>Design only V1 <sup>1)</sup>, V3 <sup>1)</sup></b>	<b>Design B3, B5</b>
400	2	6318 C3	7318 B	by request
	4, 6, 8	6322 C3	7322 B	by request
450	2	6318 C3	7318 B	by request
	4, 6, 8	6324 C3	7324 B	by request

**Note**

- 1) only suitable for vertical operation
- 2) Minimum radial load required, see page 29, NS designed as fixed bearing

**Bearing type explanation:**

Example 6315.2Z.WT.C3  
 6315 = Bearing size  
 2Z (2ZR) = non-abrasive double seal  
 C3 = bearing clearance  
 WT = polyurea grease

**IE2, IE3 and MEPS version**

Series CD ... Y2, Y3, Y	Number of poles	DS bearing, all types		NS bearing CD ... Y2, Y3, Y
		Standard (fixed bearing)	reinforced bearing <sup>2)</sup>	
71	2, 4, 6, 8	6202 2ZR	-	71
80	2, 4, 6, 8	6205 2Z	-	80
90	2, 4, 6, 8	6206 2Z C3	-	90
100	2, 4, 6, 8	6306 2Z C3	NU 306	100
112	2, 4, 6, 8	6308 2Z C3	NU 308	112
132	2, 4, 6, 8	6308 2Z C3	NU 308	132
160	2, 4, 6, 8	6309 2Z C3	NU 309	160
180	2, 4, 6, 8	6310 2Z C3	NU 310	180
200	2, 4, 6, 8	6312 2Z C3	NU 312	200
225	2, 4, 6, 8	6313 2Z C3	NU 313	225
250	2, 4, 6, 8	6315 2Z C3	NU 315	250
280	2, 4, 6, 8	6316 2Z C3	NU 316	280
315	2	6316 C3	NU 316	315
	4, 6, 8	6318 C3	NU 318	
355	2	6318 C3	NU 318	355
	4, 6, 8	6320 C3	NU 320	

Series CD ...XY	Number of poles	DS bearing, all types		NS bearing CD ...XY
		Standard (fixed bearing)	reinforced bearing <sup>2)</sup>	
250S	2, 4, 6, 8	6315 2Z C3	NU 315	250S
250M	2, 4, 6, 8	6316 2Z C3	NU 316	250M
280S	2, 4, 6, 8	6316 2Z C3	NU 316	280S
280M	2	6316 C3	NU 316	280M
	4, 6, 8	6318 C3	NU 318	
315	2	6316 C3	NU 316	315
	4, 6, 8	6318 C3	NU 318	

# Bearing

## Bearing and seal arrangement

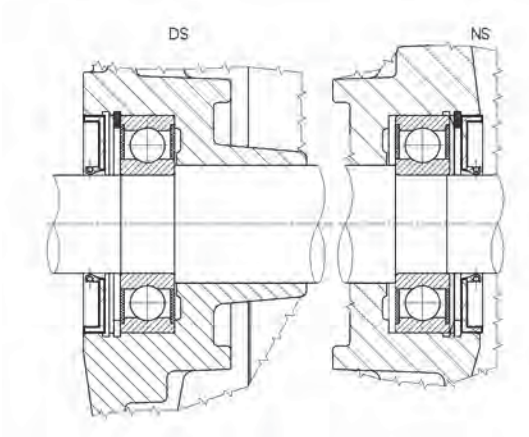

DS fixed bearing with radially shaft seal, standard for sizes 63 to 160

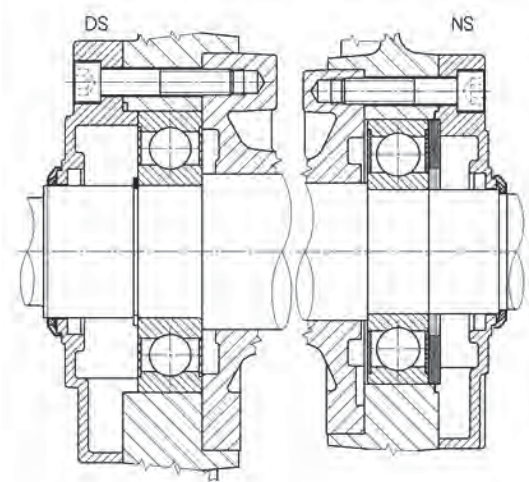

DS fixed bearing with axial shaft seal, standard from size 180

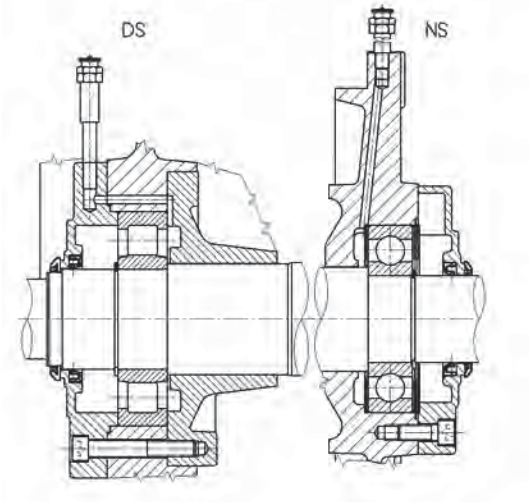

DS reinforced bearing (floating bearing; optional from size 100) with relubrication (optional from size 225) and combination seal (optional from size 80)

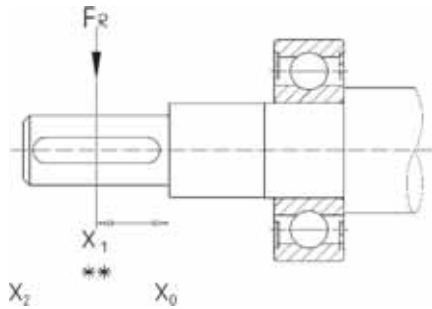

The distance of the point of application of the force  $F_R$  from the shaft shoulder should not exceed the length of the shaft end.

$F_R$  = max. radial axial force (e.g. belt pull + weight of pulley) [N]

$$F = \text{Belt pull [N]} = \frac{2 \times K \times M}{D}$$

$$M = \text{Torque [Nm]} = \frac{9550 \times P}{n}$$

P = Nominal motor power [kW]

n = Nominal motor speed [rpm]

D = Pulley diameter [m]

K = Pretension factor, which depends on the belt type, it is approximately assumed as follows

K = 3 for normal flat belts without tensioner pulley

K = 2 for normal flat belts with tensioner pulley

K = 2.2 for V-belts or special flat belts

Specifications for size 400 and larger apply to horizontal shaft only.

Permissible radial bearing load  $F_R$  [N] (deep groove ball bearing). 50 Hz

Size	Number of poles	$x_2$	$x_1$	$x_0$
63	2	400	420	450
	4	500	540	570
71	2	390	420	450
	4	490	530	570
	6	560	600	650
	8	610	660	720
80	2	650	710	780
	4	830	900	980
	6	940	1020	1120
	8	1040	1130	1240
80 Y	2	700	770	840
90	4	880	970	1060
	6	1010	1100	1220
	8	1110	1220	1340

Size	Number of poles	$x_2$	$x_1$	$x_0$	
90 Y	2	950	1050	1160	
100	4	1200	1310	1460	
	6	1360	1500	1670	
	8	1510	1660	1840	
	100 Y	2	1400	1540	1700
112	4	1760	1930	2130	
	6	2010	2200	2440	
	8	2220	2430	2690	
112 Y	2	1960	2160	2400	
132 (Y)	4	2450	2700	3000	
	6	2810	3090	3430	
	8	3110	3430	3810	
160 (Y)	2	2340	2590	2890	
	4	2960	3270	3650	
	6	3370	3730	4160	
	8	3720	4110	4590	
180 (Y)	2	3180	3530	3970	
	4	3970	4410	4960	
	6	4550	5060	5700	
	8	5010	5570	6270	
200 (Y)	2	3900	4280	4700	
	4	4930	5410	6000	
	6	5650	6190	6900	
	8	6210	6800	7500	
225 (Y)	2	4400	4800	5200	
	4	5300	5800	6500	
	6	6000	6700	7500	
	8	6700	7400	8300	
250 (Y)	2	5300	5800	6400	
	4	6600	7200	8000	
	6	7600	8300	9200	
	8	8300	9100	10100	
280 (Y)	2	5800	6200	6800	
	250M XY	4	7200	7800	8500
		6	8400	9100	9900
		8	7700	8700	10000
315 (Y)		2	5200	5600	5900
	280M XY	4	7500	8100	8800
		6	8400	9100	9900
		8	7600	8232	8979
355 (Y)		2	6300	6600	7000
	4	9200	9800	10400	
	6	10300	10900	11700	
	8	10280	10941	11692	
400	2	5100	5400	5700	
	4	9300	10000	10800	
	6	10500	11300	12100	
	8	11400	12200	13100	
450	2	4100	4400	4600	
	4	8300	8800	9500	
	6	9200	9900	10600	
	8	10100	10700	11500	

# Bearing

28

Permissible axial load, deep groove ball bearings

Permissible axial bearing load  $F_A$  [N], 50Hz

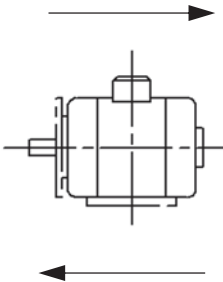
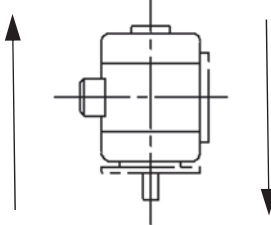
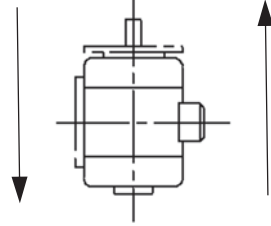
for designs	Size	3000 rpm		1500 rpm		1000 rpm		750 rpm	
		Load according to		Load according to		Load according to		Load according to	
		← N	N →	← N	N →	← N	N →	← N	N →
IM B3, IM B5, IM B35 	63	200	500	300	600	-	-	-	-
	71	200	500	300	600	400	700	500	800
	80	500	700	700	800	800	1000	1000	1100
	80 Y / 90	500	700	700	900	900	1100	1000	1200
	90 Y / 100	900	1000	1200	1300	1400	1500	1500	1700
	100 Y / 112	1300	1400	1700	1800	200	2200	2300	2400
	112 Y / 132 (Y)	1700	2100	2300	2700	2800	3200	3100	3600
	160 (Y)	2100	2700	3000	3500	3500	4100	4000	4600
	180 (Y)	2500	3200	3400	4100	4100	4800	4600	5400
	200 (Y)	3200	4100	4400	5300	5300	6200	6100	6900
	225 (Y)	3400	4900	4800	6300	5700	7300	6600	8100
	250 (Y)	4300	5800	5900	7400	7100	8600	8100	9600
	280 (Y)	4500	6300	6200	8000	7600	9400	8500	10300
	315 (Y)	4100	5900	6600	8600	7800	9800	9100	11100
	355 (Y)	4700	6700	6800	10400	8400	12000	9900	13500
	400	4200	6200	7300	11300	8700	12700	9900	13900
450	3700	5700	6300	10700	7900	13200	9100	13500	
		↓N	N ↑	↓N	N ↑	↓N	N ↑	↓N	N ↑
IM V1, IM V5, IM V15 	63	200	500	600	400	-	-	-	-
	71	200	500	300	600	400	700	500	800
	80	500	700	700	900	800	1000	900	1200
	80 Y / 90	500	800	700	1000	800	1200	900	1300
	90 Y / 100	800	1100	1100	1400	1300	1600	1400	1800
	100 Y / 112	1200	1500	1600	2000	1900	2400	2200	2600
	112 Y / 132 (Y)	1500	2300	2100	3000	2500	3500	2900	3900
	160 (Y)	1800	3100	2600	4000	3100	4700	3500	5200
	180 (Y)	2100	3700	2800	4900	3400	5600	4000	6300
	200 (Y)	2600	4900	3700	6300	4500	7300	5100	8200
	225 (Y)	2600	5900	3700	7700	4500	8900	5400	9800
	250 (Y)	3300	7100	4500	9300	5500	10700	6300	12000
	280 (Y)	3000	8300	4100	10800	5500	12100	6100	13700
	315 (Y)	600	10400	1800	14900	2000	17600	3300	18900
	355 (Y)	100	12800	700	18800	1100	21900	2500	23400
	400	7300	0	19400	0	22100	0	23600	0
450	4800	0	14700	0	16900	0	18000	0	
		↓N	N ↑	↓N	N ↑	↓N	N ↑	↓N	N ↑
IM V3, IM V6, IM V35 	63	500	200	600	400	-	-	-	-
	71	500	200	600	400	700	500	700	500
	80	600	500	800	700	900	900	1100	1000
	80 Y / 90	700	600	900	800	1000	1000	1100	1100
	90 Y / 100	900	900	1200	1300	1400	1500	1600	1700
	100 Y / 112	1300	1400	1700	1900	2000	2200	2300	2500
	112 Y / 132 (Y)	2000	1900	2500	2600	2900	3100	3300	3400
	160 (Y)	2400	2600	3100	3500	3600	4200	4000	4700
	180 (Y)	2800	3000	3600	4100	4200	4900	4700	5600
	200 (Y)	3500	4100	4600	5400	5300	6500	5900	7300
	225 (Y)	4100	4400	5200	6200	6000	7400	6900	8300
	250 (Y)	4800	5600	6100	7700	7100	9200	7800	10500
	280 (Y)	4800	6500	5900	900	7300	10300	7900	11900
	315 (Y)	2400	8600	3800	12900	4000	15600	5300	16900
	355 (Y)	2100	10800	4300	15200	4700	18300	6100	19800
	400	7300	0	19400	0	22100	0	23600	0
450	4800	0	14700	0	16900	0	18000	0	

Permissible radial load, cylindrical roller bearing

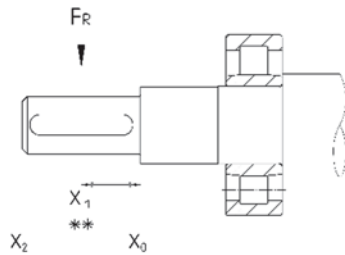

The distance of the point of application of the force  $F_R$  from the shaft shoulder should not exceed the length of the shaft end.

$F_R$  = max. radial axial force (e.g. belt pull + weight of pulley) [N]

$$F = \text{Belt pull [N]} = \frac{2 \times K \times M}{D}$$

$$M = \text{Torque [Nm]} = \frac{9550 \times P}{n}$$

- P = Nominal motor power [kW]
- n = Nominal motor speed [rpm]
- D = Pulley diameter [m]
- K = Pretension factor, which depends on the belt type, it is approximately assumed as follows
- K = 3 for normal flat belts without tensioner pulley
- K = 2 for normal flat belts with tensioner pulley
- K = 2.2 for V-belts or special flat belts

Specifications for size 400 and larger apply to horizontal shaft only.

**Minimum load  $F_{R \text{ min with } x_0}$**

Due to their reinforced design, the bearings must be loaded with at least the forces specified in the table. Even an unloaded test run can lead to damage.

Permissible radial bearing load  $F_R$  [N] (cylindrical roller bearing), minimum load.

Size	Number of poles	$x_2$	$x_1$	$x_0$	$F_{R \text{ min with } x_0}$
<b>100</b>	2	2759	3033	3367	220
	4	3392	3729	4139	205
	6	3826	4206	4669	200
	8	4176	4590	5095	198
<b>100 Y</b>	2	3702	4054	4480	277
<b>112</b>	4	3766	4984	5507	255
	6	3766	5621	6212	248
	8	3766	6137	6780	245
<b>112 Y</b>	2	5782	6363	7073	475
<b>132 (Y)</b>	4	6451	7814	8686	428
	6	6451	8818	9802	412
	8	6451	9641	10717	404
<b>160 (Y)</b>	2	3900	5582	7958	599
	4	3900	5582	9803	536
	6	3900	5582	9803	515
	8	3900	5582	9803	505
<b>180 (Y)</b>	2	7912	8735	9749	748
	4	8900	10715	11959	662
	6	8900	12108	13513	633
	8	8900	13196	14727	619
<b>200 (Y)</b>	2	10869	11918	13191	1102
	4	12180	14680	16248	957
	6	12180	16575	18345	909
	8	12180	18050	19978	885
<b>225 (Y)</b>	2	12850	14319	15672	1302
	4	12850	17158	19220	1124
	6	12850	19377	21706	1065
	8	12850	19392	23719	1035
<b>250 (Y)</b>	2	12300	18385	20871	1795
	4	12300	18385	25620	1519
	6	12300	18385	28920	1427
	8	12300	18385	31497	1381
<b>280 (Y)</b>	2	15300	20423	22313	2060
	4	15300	22611	27359	1733
	6	15300	22611	31044	1624
	8	15300	22611	31044	1570
<b>315 (Y)</b>	2	9800	14183	21892	2060
L2, L3	2	5800	8394	15187	2060
<b>315 (Y)</b>	4	13500	20566	32744	2228
	L2, L3	4	8500	12949	27171
<b>315 (Y)</b>	6,8	12500	19043	36426	2073
	L2, L3	6,8	7600	11578	24294
<b>355 (Y)</b>	2	16800	24127	25751	2692
	L3	2	15000	21542	25481
<b>355 (Y)</b>	4	12400	18475	36219	2930
	L3	4	12000	17879	35051
<b>355 (Y)</b>	6	10280	15316	30027	2698
	8	10280	15316	30027	2698
	400	2	22171	23265	24472
<b>400</b>	4	20000	30096	45197	3675
	6	19000	28591	50501	3369
	8	18000	27087	54618	3216
	<b>450</b>	2	20598	21823	23202
<b>450</b>	4	40000	47774	51495	4409
	L2	4	34200	47537	50949
<b>450</b>	6	32500	49311	56917	4023
	8	31000	47034	61566	3829

Values for high-voltage motors by request.

# Bearing

Rotor weights for CD ...(Y2,Y3,Y) series

## Rotor weights [kg]

Size	Type Y	2p = 2 3000 rpm	2p = 4 1500 rpm	2p = 6 1000 rpm	2p = 8 750 rpm	
63 Y2,Y3,Y	M1	by request	1,6	---	---	
	M2	by request	1,9	---	---	
63	M1	1,5	1,8			
	M2	1,5	1,8			
71	M1	1,4	1,5			
	M2	1,6	1,9	2,6	2,6	
80	M1	2,2	2,7	3,7	3,7	
	M2	2,7	3,3	4,5	4,5	
90	S	80M1...Y2,Y3,Y	3	3,7	4,5	4,5
	L	80M2...Y2,Y3,Y	3,5	4,4	5,8	5,8
100	L		4,9		8,4	
	L1	90S...Y2,Y3,Y	4,9	5,8	6,9	6,9
	L2	90L...Y2,Y3,Y	5,6	6,8	8,4	8,4
112	M	100L...Y2,Y3,Y	6,5	9,9	12,1	12,1
	S	112M...Y2,Y3,Y		15,2	19	17,6
132	S1	112M...Y2,Y3,Y	10,7			
	S2		12,4			
		132S2...Y2,Y3,Y	15,7			
	M	132S...Y2,Y3,Y		16,7	17,3	16
		132M...Y2,Y3,Y		23,7		19,2
	M1	132M...Y2,Y3,Y			19,4	
	M2	132M2...Y2,Y3,Y			22,2	
		132M2...Y2,Y3,Y		24,5		
	M			31,9	38,1	
		...Y2,Y3,Y		33	40,9	
160	M1	...Y2,Y3,Y	20,8			28,7
	M2	...Y2,Y3,Y	24,7			34,3
	L		27,5	33	40,9	
		...Y2	27,5	34,1	40,9	
		...Y3, Y	27,5	37,3	46,2	42,7
180	M		38,5	48,5		
		...Y2,Y3,Y	38,5	51,6		
	L			51,6	61,4	67,6
		...Y2		51,6	61,4	67,6
	...Y3, Y		55,9	61,4	67,6	
200	L	...Y2,Y3,Y		74		95,9
	L1	...Y2,Y3,Y	50,4		51,1	
	L2	...Y2,Y3,Y	61,4		84,4	
225	S	...Y2,Y3,Y	---	93,7	104,3	
	M	...Y2,Y3,Y	76	108	122	122
250	M	...Y2,Y3,Y	99	136	156	176
	S	...Y2,Y3,Y	109	144	148	179
280	M	...Y2,Y3,Y	122	163	171	207
	S	...Y2,Y3,Y	155	215	269	250
315	M	...Y2,Y3,Y	181	261	300	290
	L1	...Y2,Y3,Y	208	293	360	338
	L2	...Y2,Y3,Y	260	338	491	452
	L3	...Y2,Y3,Y	340	465	576	576
	M				582,5	629
355	L1		450	605	727	727
	L2		486	656	879	880
	L3		548	737		
	M			856	1006	1147
400	L		688	936	1107	1264
	M			1066	1237	1399
450	L			1148	1340	1541
	M					
500		by request				

**Maintenance-free run time with lifetime lubrication and coupling operation for horizontal designs**

Motors with standard power			Motors with increased power (...X, ...W)		
Size	Number of poles	RT 40 °C	Size	Number of Poles	RT 40 °C
63-71	2	20000 h	63-71	2	20000 h
	4, 6, 8	40000 h		4, 6, 8	40000 h
80-90	2	20000 h	80-90	2	15000 h
	4, 6, 8	40000 h		4, 6, 8	30000 h
100-132	2	20000 h	100-132	2	10000 h
	4, 6, 8	40000 h		4, 6, 8	20000 h
160-280	2	20000 h	160-280	2	7500 h
	4, 6, 8	40000 h		4, 6, 8	15000 h

**Relubrication times for horizontal designs**

Room temperature	Relubrication time for motors with standard power		Room temperature	Relubrication time for motors with increased power (...X, ...W)	
	Speed up to 1800 rpm	up to 3600 rpm		Speed up to 1800 rpm	
40 °C	5000 h	2500 h	5000 h	2500 h	
50 °C	2500 h	1000 h	2500 h	1000 h	
60 °C	2000 h	500 h	-	-	

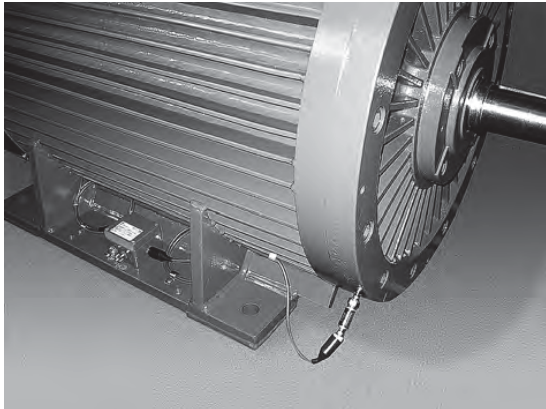

Vibration transducer and box

**Bearing monitoring**

For condition monitoring of the bearing, the motors can be equipped with temperature sensors, shock pulse transducers and vibration transducers.

PT100 temperature sensors are mounted inside the flameproof enclosure at the bearing points. Standard version with 2-wire circuit, 3 or 4-wire circuit optional. The connection is made either in the main terminal compartment or in separate additional compartments, which are attached to the main box or the motor housing, depending on the design. The wiring and design of the boxes can be implemented with the Ex d, Ex e or Ex i protection type, as required.

For wear condition monitoring, shock pulse nipples can be mounted on the outside of the end shields from size 132. This makes monitoring with mobile recording devices possible. For remote monitoring, it is also possible to use hard-wired shock pulse or vibration transducers. The individual transducers are brought together in a separate terminal compartment. The connection takes place with protection type Ex ia IIC T4.

# Bearing

### Bearing currents, isolated bearings

A voltage along the shaft can occur in mains-fed motors because of magnetic unbalances. This shaft voltage leads to equalizing currents between the rotor and the stator, which flow through the roller bearings. If the voltage exceeds a peak value of 500 mV, the bearings can be damaged. This risk is only present with bigger axle heights.

Operation on the frequency converter can intensify these effects. The design of the inverter has a decisive influence in this case. Pulse inverters generate extremely high-frequency voltages and currents depending on the clock frequency and the pulse modulation. These effects are minimized by output filters in the inverters.

To avoid bearing damage, an insulated bearing is therefore always installed at the counter drive side of motors for inverter operation from size 315. The operator must also provide wide-area grounding

of the motor housing so that the currents circulating between the inverter and the stator can flow away via this.

High-voltage motors are always fitted with an insulated bearing at the counter drive side.

### Mechanical limit speeds

When the motors are being operated above the rated speed, the limits of the roller bearings, the strength of the rotating parts, critical rotor speeds and the peripheral speed of the fans must be observed. The limiting speeds specified in the adjacent table may already require measures such as special fans, special bearings or special balancing.

The speeds specified in the operating data starting on page 62 for inverter operation, are achieved with the standard motor..

### Mechanical limit speeds

Number of poles	Assembly	63/71	80	90	100	112	132	160	180	200	225	250	280	315	355	400	450
2	[rpm]	30000	19000	15000	12000	12000	10000	9000	6000	5220	6500	7300	6300	5300	3600	3600	3600
	[Hz]	500	317	250	200	200	167	150	100	87	108	120	105	88	60	60	60
4	[rpm]	4500	4500	4500	4500	4500	4500	4500	4000	4000	4000	3600	3000	3000	3000	3000	3000
	[Hz]	150	150	150	150	150	150	150	133	133	133	120	100	100	100	100	100
6	[rpm]	4000	4000	4000	4000	4000	4000	4000	3600	3600	3000	3000	2500	2500	2500	2000	2000
	[Hz]	200	200	200	200	200	200	200	180	180	150	150	125	125	125	100	100
8	[rpm]	4000	4000	4000	4000	4000	4000	4000	3600	3600	3000	3000	2500	2500	2500	1500	1500
	[Hz]	267	267	267	267	267	267	267	240	240	200	200	167	167	167	100	100

## Shaft ends

The motors are normally provided with a free shaft end whose dimensions correspond with EN 50347.

From size 63, the shaft ends have a female thread in accordance with DIN 332 type "D". The feather keys are designed in accordance with DIN 6885 sheet 1.

By request, motors with a special shaft or/and a second shaft end can be supplied at additional cost (not for motors with axial fan and motors with attachments at the N side, e.g. speedometer attachment).

## Concentricity of the shaft ends

The concentricity of the shaft ends corresponds to EN 50347. If desired, the values can be reduced by 50%.

## Balancing

The motors are dynamically balanced with half a feather key. The balance quality corresponds to

DIN ISO 1940, at least G2.5. Special versions, balanced with a whole feather key or without a feather key, are optionally available.

The motors are marked in the shaft mirror as follows in accordance with DIN ISO 8821:

H = half wedge balancing

F = Full wedge balancing

N = Balancing without feather key

## Vibration severity

The mechanical vibrations in accordance with EN 60034-14 correspond to level A as standard. In the case of special mechanical running smoothness requirements, the low-vibration version level B (reduced) can be supplied.

### Vibration severity with free suspension

v <sub>eff</sub> [mm/s]	Size		
	63–132	160–280	315–450
Level A	1,6	2,2	2,8
Level B	0,7	1,1	1,8

## Direct gearbox attachment

The motors in the "oil-protected flange" version are suitable for direct mounting to gearboxes. The sealing at the shaft is provided by radial sealing rings in accordance with DIN 3760. The available flanges can be found in the table on page 38.

The sealing ring must be lubricated by spray oil or oil mist.

Motors up to size 450 have the fixed bearing at the drive side to limit the thermal expansion of the rotor in relation to the gearbox.

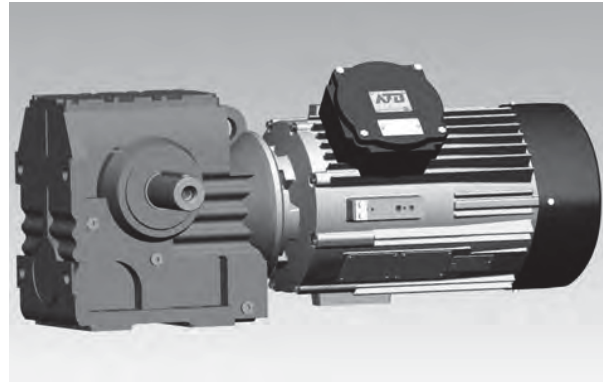

## Foundations

The foundations must comply with the requirements and assessments of DIN ISO 10816-3. They must be either rigid or elastic as defined in the standard.

The restriction to max. 2.8 mm/s applies for motors with a flameproof enclosure.

# Operating noise, cooling air volume

## Operating noise

The noise limits of EN 60034-9 are undershot by a long way. Noise measurements are performed in accordance with EN ISO 1680 and EN 21680 according to accuracy class 2 in an anechoic chamber.

In the operating data sheets, the sound pressure level "Lp" and the sound power level "Lw" are specified in dB(A) for the individual sizes. They apply for a nominal load at 50 Hz, plus a tolerance of +3 dB(A).

For the design types of low-noise motors, see Page 35 and 36.

## Cooling air volume and permissible back pressure

If the motors are to be operated via pipe systems or under sound insulation hoods, the minimum cooling air quantities listed in the table below must be adhered to. The maximum back pressures must not be exceeded to ensure that the self-ventilation functions properly.

Cooling in the external air flow is possible. A cooling air flow of at least 15 m/s to the cooling fins is required.

## Cooling air volumes and permissible back pressure

Size	3000 rpm		1500 rpm		1000 rpm		750 rpm	
	Cooling air volume m <sup>3</sup> /s	permissible counter pressure Pa	Cooling air volume m <sup>3</sup> /s	permissible counter pressure Pa	Cooling air volume m <sup>3</sup> /s	permissible counter pressure Pa	Cooling air volume m <sup>3</sup> /s	permissible counter pressure Pa
71	0.01	20	0.01	10	0.01	5	0.01	3
80	0.03	30	0.03	10	0.02	5	0.01	3
90	0.05	40	0.03	10	0.02	6	0.01	4
100	0.07	50	0.07	12	0.03	8	0.02	4
112	0.08	50	0.06	12	0.03	8	0.02	5
132	0.1	70	0.1	18	0.07	10	0.05	5
160	0.2	90	0.2	30	0.1	15	0.08	8
180	0.4	100	0.3	40	0.15	20	0.1	10
200	0.5	120	0.3	50	0.2	25	0.15	12
225	0.6	120	0.6	50	0.3	30	0.23	15
250	0.7	140	0.5	60	0.33	35	0.28	20
280	0.7	160	0.7	80	0.45	45	0.33	25
315	1	160	1	80	0.6	45	0.45	25
355	1.5	160	1.2	80	1	45	0.8	25
400	2.2	180	1.9	100	1.7	55	1.5	35
450	2.9	200	2.5	120	2.2	65	2	45

### Noise class 1 standard version

For the standard version, radial fans are used which are suitable for both directions of rotation. The fans that are used transport large volumes of air with good efficiency and low noise.

### Noise class 2 axial fan, Type series ...A - low-noise

For higher demands, the low-noise version with the axial fan that is dependent on the direction of rotation is recommended. These fans are available for 2-pole motors from size 112 and for 4-pole motors from size 132.

The aerodynamic design of the fan blades and the optimum angle of attack allow the noise of the 2-pole motors to be reduced by up to 10 dB(A) in comparison to the standard version.

### Noise class 3 axial fan in special design, series ...AR - very low noise

If particularly high demands are being made of having a low-noise design, we have developed a very quiet surface-cooled three-phase motor. Compared to the standard version with radial fan, these motors are approx. 12 dB(A) quieter in the 2-pole version and achieve a further noise reduction compared to the low-noise version with an axial fan.

Tables with operating data for classes 1 to 3 can be found on pages 62 and 64.

An overview of the low-noise motors can be found on page 36.

### Noise class 4 water cooling, series ...W - version with the least noise

The water-cooled motors have the following advantages:

- Reduction of the noise level due to omission of the fan
- Avoidance of air turbulence in dusty operating areas (dust explosion hazard)
- Performance increase by an additional type compared to EN 50347
- The mounting dimensions of the IEC sizes remain unchanged
- Good heat dissipation without room heating
- Good prerequisite for utilizing the heat loss via heat exchangers

The motor housing is welded from steel and is double-walled for water cooling. The water jacket has several coats of plastic on the inside to prevent corrosion damage.

The specified capacities relate to a maximum water inlet temperature of 30 °C. A suspension content of max. 30 mg/l in the cooling water is permissible.

All motors generally have PTC thermistor temperature sensors as overload protection. Flow monitors for monitoring the cooling water are there not required.

Tables containing operating data can be found on page 119.

### Frequency inverter operation

All systems are suitable for inverter operation without restrictions.

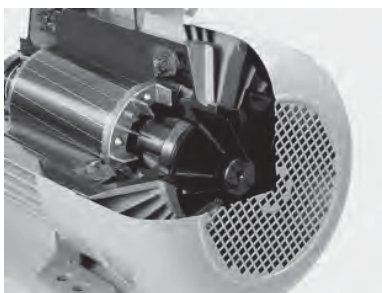

Centrifugal fan, independent of direction of rotation (noise class 1)

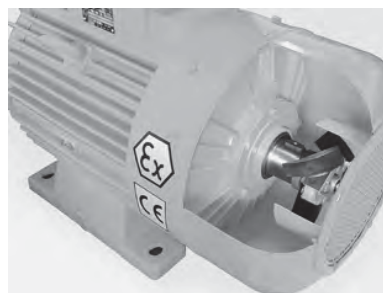

Axial fan, fan guard with inlet nozzle, dependent on direction of rotation (noise class 2 and 3)



Water-cooled motor (noise class 4)

# Customised motors

36

Low noise motors, sound level

## Sound level

Noise class		1		2		3		4		
		Standard version (radial fan)		Type series ...A low noise version (axial fan)		Type series ...AR extremely low-noise design (axial fan)		Type series ...W extremely low-noise design, water-cooled		
		Temperature class T4, 50Hz		Temperature class T4, 50Hz		Temperature class T4, 50Hz		Temperature class T4, 50Hz		
Size	Output	Sound pressure level	Sound power level	Sound pressure level	Sound power level	Sound pressure level	Sound power level	Output	Sound pressure level	Sound power level
	P <sub>2</sub>	L <sub>p</sub> [dB (A)]	L <sub>w</sub> [dB (A)]	L <sub>p</sub> [dB (A)]	L <sub>w</sub> [dB (A)]	L <sub>p</sub> [dB (A)]	L <sub>w</sub> [dB (A)]	P <sub>2</sub> [dB (A)]	L <sub>p</sub> [dB (A)]	L <sub>w</sub> [dB (A)]
<b>ns = 3000 rpm, 2p = 2</b>										
112 M-2	4	63	75	55	67	-	-	-	-	-
112 M-2Y	4	63	76	55	68	-	-	-	-	-
132 S1-2 (Y)	5,5	63	76	55	68	54	67	-	-	-
132 S2-2 (Y)	7,5	63	76	55	68	54	67	-	-	-
160 M1-2 (Y)	11	66	79	56	69	54	67	15	50	63
160 M2-2 (Y)	15	66	79	56	69	54	67	18,5	50	63
160 L-2 (Y)	18,5	66	79	56	69	54	67	22	50	63
180 M-2 (Y)	22	69	82	58	71	57	70	30	51	64
200 L1-2 (Y)	30	71	85	60	74	58	72	37	52	66
200 L2-2 (Y)	37	71	85	60	74	58	72	45	52	66
225 M-2 (Y)	45	72	86	60	74	59	73	55	54	68
250 M-2 (Y)	55	75	89	64	78	62	76	75	57	71
280 S-2 (Y)	75	76	90	66	80	64	78	90	59	73
280 M-2 (Y)	90	76	90	66	80	64	78	110	59	73
315 S-2 (Y)	110	76	91	66	81	64	79	132	60	75
315 M-2 (Y)	132	76	91	66	81	64	79	160	60	75
315 L1-2 (Y)	160	76	91	66	81	64	79	200	60	75
315 L2-2 (Y)	200	76	91	66	81	65	80	250	60	75
315 L3-2 (Y)	250	76	91	66	81	65	80	315	60	75
355 L1-2 (Y)	315	81	96	68	84	66	82	355	60	76
355 L2-2 (Y)	355	81	96	68	84	66	82	400	60	76
355 L3-2 (Y)	400	81	96	68	84	66	82	-	-	-
<b>ns = 1500 rpm, 2p = 4</b>										
132 S-4 (Y)	5,5	57	70	55	68	-	-	-	-	-
132 M-4 (Y)	7,5	57	70	55	68	-	-	-	-	-
160 M-4 (Y)	11	62	75	56	69	-	-	-	-	-
160 L-4 (Y)	15	62	75	56	69	-	-	-	-	-
180 M-4 (Y)	18,5	60	73	57	70	56	69	22	51	64
180 L-4 (Y)	22	60	73	57	70	56	69	27	51	64
200 L-4 (Y)	30	61	75	58	72	57	71	37	51	65
225 S-4 (Y)	37	63	77	59	73	58	72	45	52	66
225 M-4 (Y)	45	63	77	59	73	58	72	55	52	66
250 M-4 (Y)	55	65	79	64	78	63	77	70	56	70
280 S-4 (Y)	75	68	82	66	80	65	79	90	58	72
280 M-4 (Y)	90	68	82	66	80	65	79	110	58	72
315 S-4 (Y)	110	69	84	66	81	65	80	132	57	72
315 M-4 (Y)	132	69	84	66	81	65	80	160	57	72
315 L1-4 (Y)	160	69	84	66	81	65	80	200	57	72
315 L2-4 (Y)	200	69	84	66	81	65	80	250	57	72
315 L3-4 (Y)	250	69	84	66	81	65	80	315	57	72
355 L1-4 (Y)	315	72	88	68	84	67	83	355	58	74
355 L2-4 (Y)	355	72	88	68	84	67	83	400	58	74
355 L3-4 (Y)	400	72	88	68	84	67	83	400	58	74

On board ships, particularly when installed on the upper deck, on drilling platforms, in harbour facilities and also in wastewater technology, e.g. in sewage treatment plants, the corrosion resistance of electrical machines is under severe stress from high humidity, salty air and short-term flooding. The same applies to fan motors in cooling systems and cooling towers.

Motors with a special corrosion-protected design have been developed for these applications. In addition to the well-known features of the industrial motor series such as

- long life
- long maintenance intervals
- high efficiency and power factor
- low noise pollution of the environment

they are characterized by a series of corrosion and water protection measures in the surface protection, sealing and ventilation areas.

Type examination certificates from various classification societies such as DNV GL, Nippon Kaiji Kyokai and Lloyd's Register, are available for this special motor design. This certifies the special suitability for the maritime area.

To prevent heavy dew formation on the stator winding in the event of large temperature fluctuations and load changes, e.g. for periodic downtimes, the motors can be equipped with a stationary heater.

This can be fitted to the winding heads either in the form of heating tapes or by feeding the stator winding with a reduced voltage.

Potting of the winding heads is possible as another protective measure. This measure can be applied instead of a stationary heater.

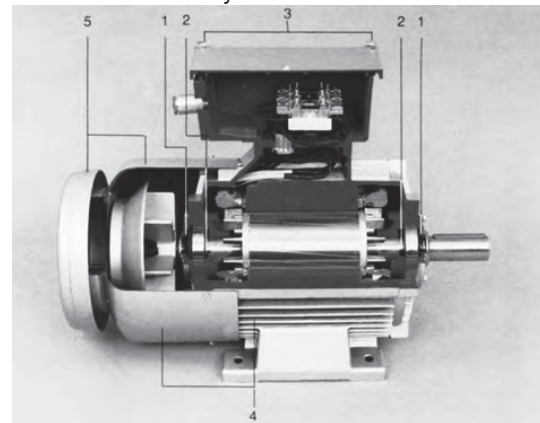

1. Salt water-resistant double seals
2. Stainless steel corrosion resistant shafts
3. Stainless steel fastening screws
4. Salt water-resistant multiple special coating, also with zinc primer
5. Reinforced fan guard with canopy and baffle plate to protect the fan in heavy seas

#### Special designs for upper deck installation

Components	Measures
Motor protection class and terminal compartment	IP56 in accordance with DIN EN 60 034 part 5
Shafts	the motors have stainless steel shafts
Sealing in the shaft area at the D-side and the N-side	radial shaft seals in accordance with DIN 3760 are used up to size 160, and from size 180 the motors have a combined seal consisting of a radial seal and an axial seal
Fan guard, canopy	reinforced fan cowls for size 71 to 160; material thickness 2mm from size 180 for all designs Fan cowls with protective roof and baffle plate; material thickness ≤3mm
Fan	Fan in salt water-resistant Al alloy or steel
Fastening screws	General use of stainless steel screws (A 2-70)
Cable entry	When supplied with cable glands, metal glands certified in accordance with DIN EN 60079 are used
Paint	Special coating with zinc primer

# Customised motors

## Universal Chemistry Motor

The Universal Chemistry Motor was designed to realize cost-saving warehousing by means of universal use of a motor.

The picture shows how to replace the flanges, the feet, the lifting lugs and the canopy. This means that all possible designs in accordance with EN 60034-7 can be realized from the starting point of a basic motor.

All of these operations can be performed without opening the flameproof compartment. Authorization by an expert is not required for recommissioning. The conversion is reversible, meaning that a motor can be used successively in different locations.

The basic version includes:

- PTC thermistor protection and an identification plate for operation on any frequency inverter
- VIK version
- IE3 version in accordance with EN 60079-30

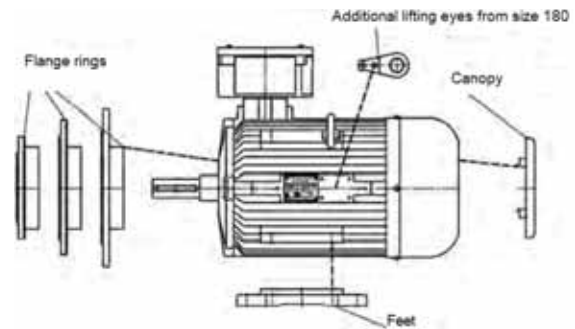

### Flanges available

Size	FF-flanges Ø in mm <sup>1)</sup>												FT-flanges Ø in mm <sup>1)</sup>								
	100	115	130	165	215	265	300	350	400	500	600	740	65	75	85	100	115	130	165	215	
	A-flanges Ø in mm <sup>1)</sup>						C-flanges Ø in mm <sup>1)</sup>														
	120	140	160	200	250	300	350	400	450	550	660	800	80	90	105	120	140	160	200	250	
63	0	X	0	0	0	0	0	0	0	0	0	0	0	0	X	0	0	0	0	0	
71	0	0	X	0	0	0	0	0	0	0	0	0	0	0	0	X	0	0	0	0	
80	0	0	0	X	0	0	0	0	0	0	0	0	0	0	0	X	0	0	0	0	
80 Y		0	0	X	0	0	0	0	0	0	0	0	0	0	0	X	0	0	0	0	
90 (Y)		0	0	X	0	0	0	0	0	0	0	0			0	0	X	0	0	0	
100 (Y)			0	0	X	0	0	0	0	0	0	0				0*	0	X	0	0	
112 (Y)			0	0	X	0	0	0	0	0	0	0						X	0	0	
132 (Y)					0	X	0	0	0	0	0	0						0	X	0	
160 (Y)					0	0	X	0	0	0	0	0								X	
180 (Y)					0	0	X	0	0	0	0	0									
200 (Y)							0	X	0	0	0	0									
225 (Y)								0	X	0	0	0									
250 (Y)									0	X	0	0									
280 (Y)									0	X	0	0									
315 (Y)										0	X	0									
355 (Y)											0	X									

X = standard

\* = not available for design Y

0 = Special flange (additional price)

All other versions require an intermediate ring (additional price).

#### Notes

<sup>1)</sup> new marking in accordance with EN 50347

old marking in accordance with DIN 42948

Our motors are designed for a wide range of applications. A number of attachments and built-in components have been developed to fulfil the different applications. The standardized mounting or installation of brakes, tachometers, pulse generators and backstops is therefore particularly cost-effective. Combinations of different designs can easily be realized by installing one component.

The possibility of attachment exists from size 80. The explosion-proof equipment is mounted on a reinforced fan guard and connected to the motor shaft either directly or by means of a backlash-free coupling.

In the case of IE2 and IE3 motors, the axial dimension may be exceeded during installation due to the design.

For sizes 80 - 132 of the IE1 version, it is also possible to install brakes or encoders directly in the flameproof motor enclosure.

### Speed sensor

Actual value transmitters are used for electrical remote measurement and for controlling the motor speed. These devices convert the "speed" input variable into an analog or digital electrical signal.

Attached devices are connected in a separate terminal box.

For motors with a built-in encoder (series ...R) the connection is made in the main terminal compartment of the motor.



Motor with built-in incremental encoder

### Backstop

When transport systems or pumps are being operated, the backstop prevents backwashing after switching off the motor.

For sizes 80 to 100 it is possible to install a blocking ball bearing. This is particularly recommended if this design is going to be combined with another attachment. Although the locking elements are integrated in the bearing, the load carrying capacity of the bearing is only marginally reduced compared to a normal bearing. However, since the blocking elements come into contact with the raceways, the maximum speed is limited to 1500 rpm, and the service life of the bearing will be reduced.

From size 90, the backstop can also be mounted on a reinforced fan guard directly on the extended motor shaft. This backstop is designed so that the clamping pieces are lifted up from the stationary outer race by centrifugal force, whereby the minimum speed is maintained. There are therefore no additional frictional forces or noises with this design.

### Technical data of the backstop

Size	Blocking Bearing DS type	Nominal torque [Nm]	Service life with 1500 rpm [h]
80	ZZ 6204 L	32	3800
80 Y / 90	FC 6205	40	5600
90 Y / 100	ZZ 6206 M	110	1900
Size	Backstop Type	Nominal torque [Nm]	Lift-off speed [rpm]
90	FXM 31-17 NX	100	890
100	FXM 38-17 NX	150	860
112	FXM 38-17 NX	150	860
132	FXM 38-17 NX	150	860
160	FXM 66-25 NX	800	700
180	FXM 66-25 NX	800	700
200	FXM 86-25 NX	1350	630
225	FXM 86-25 NX	1350	630
250	by request		
280	by request		

# Customised motors

## Brake motors with mounted brake type CD...SM(N)

Our motors can be supplied with several variants of spring-applied brakes with a flameproof enclosure. Mounted in a flanged version at the drive side (type...SM and SV) or on a reinforced fan guard at the non-drive side of the motor (type ...SMN, SVN and S). The electrical connection is made in a separate terminal compartment on the brake.

### Series ...SM and ...SMN

The SM and SMN brakes are available for sizes 71 to 160. The brake can be mounted at the drive side (SM) as well as the NDE (SMN) to a reinforced fan guard. The electrical connection is made optionally in an Ex eb or Ex db terminal compartment that can be rotated in steps of 90°.

This brake is available in the following versions:

- Size 71 - 160
- 4 - 150 Nm depending on size
- 24 - 207 VDC
- 230 - 460 VAC
- Category 2G / 2D/ 2GD
- Protection class Ex db / Ex db eb
- Protection group IIC
- Temperature class T3 / T4 / T5 / T6
- Max. surface temperature 200 °C / 135 °C / 100 °C / 85 °C
- Protection class IP66
- Ambient temperature -20 °C to + 40 °C / -60 °C to + 60 °C
- Thermal protection via PTC thermistor temperature sensor
- Manual release (optional)
- Release control via microswitch or initiator (optional)
- Wear control via microswitch
- Anti-condensation heating (optional)
- Special flange or special shaft by request



Motor with attached brake type CD...SM

### Braking torques<sup>1)</sup>, wear values

Size CD...SM(N)	Braking torques	Friction work	
	M <sub>2</sub> [Nm]	Q <sub>r 0,1</sub> [J]	Q <sub>r ges</sub> [J]
71	5	8x10 <sup>6</sup>	20x10 <sup>6</sup>
	4 <sup>1)</sup>	8x10 <sup>6</sup>	20x10 <sup>6</sup>
	3	8x10 <sup>6</sup>	20x10 <sup>6</sup>
	2	8x10 <sup>6</sup>	20x10 <sup>6</sup>
80	11,8	20x10 <sup>6</sup>	100x10 <sup>6</sup>
	8 <sup>1)</sup>	20x10 <sup>6</sup>	100x10 <sup>6</sup>
	6,8	20x10 <sup>6</sup>	100x10 <sup>6</sup>
	5,5	20x10 <sup>6</sup>	100x10 <sup>6</sup>
90	20	20x10 <sup>6</sup>	100x10 <sup>6</sup>
	16 <sup>1)</sup>	20x10 <sup>6</sup>	100x10 <sup>6</sup>
	13,5	20x10 <sup>6</sup>	100x10 <sup>6</sup>
	11,8	20x10 <sup>6</sup>	100x10 <sup>6</sup>
112	60	29x10 <sup>6</sup>	159x10 <sup>6</sup>
	50 <sup>1)</sup>	29x10 <sup>6</sup>	159x10 <sup>6</sup>
	42	29x10 <sup>6</sup>	159x10 <sup>6</sup>
	30	29x10 <sup>6</sup>	159x10 <sup>6</sup>
132	125	29x10 <sup>6</sup>	159x10 <sup>6</sup>
	100 <sup>1)</sup>	29x10 <sup>6</sup>	159x10 <sup>6</sup>
	85	29x10 <sup>6</sup>	159x10 <sup>6</sup>
	70	29x10 <sup>6</sup>	159x10 <sup>6</sup>
160	50	29x10 <sup>6</sup>	159x10 <sup>6</sup>
	180	47x10 <sup>6</sup>	282x10 <sup>6</sup>
	150 <sup>1)</sup>	47x10 <sup>6</sup>	282x10 <sup>6</sup>
	125	47x10 <sup>6</sup>	282x10 <sup>6</sup>
	100	47x10 <sup>6</sup>	282x10 <sup>6</sup>
	75	47x10 <sup>6</sup>	282x10 <sup>6</sup>

#### Notes:

<sup>1)</sup> Standard torque

Holding brakes with higher braking torque and friction power by request

The possible friction work Q<sub>r</sub> can be calculated in accordance with the following formulas. Please refer to the table for the wear limits.

$$Q_r = \frac{J \times n^2}{182.4} \times \frac{M_2}{M_v} \text{ [J]}$$

$$M_v = M_2 + [-] \times ML$$

\* Sign in brackets [-] applies with load braked downwards

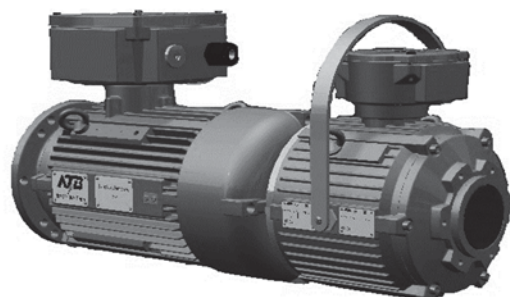

Motor with mounted brake type CD...SMN

## Switching times, after-run revolutions

Size	Nominal torque	Link time		Response - time		After-run AC side - disconnection	DC side - disconnection -
		t <sub>1</sub> =	t <sub>1</sub> ~	t <sub>11</sub> =	t <sub>11</sub> ~		
CD...SM(N)	[Nm]	[ms]	[ms]	[ms]	[ms]	Revolutions	Revolutions
71M1-2	4	18	160	12	130	4,6	11,1
71M2-2	4	18	160	12	130	5,0	11,5
80M1-2	8	55	300	40	250	8,1	19,4
80M2-2	8	55	300	40	250	9,1	20,4
90S-2	16	55	300	40	250	8,0	19,4
90L-2	16	55	300	40	250	9,0	20,4
100L-2	50	55	500	35	400	6,8	27,0
112M-2	50	55	450	50	400	8,3	27,0
132S1-2	100	68	640	50	400	7,9	30,9
132S2-2	100	68	640	50	400	8,7	31,8
160M1-2	150	80	730	40	400	9,4	34,7
160M2-2	150	80	730	40	400	10,6	35,8
160L-2	150	80	730	40	400	11,5	36,8
71M1-4	4	18	160	12	130	2,1	5,4
71M2-4	4	18	160	12	130	2,3	5,5
80M1-4	8	55	300	40	250	3,1	8,7
80M2-4	8	55	300	40	250	4,0	9,7
90S-4	16	55	300	40	250	3,6	9,3
90L-4	16	55	300	40	250	3,9	9,6
100L1-4	50	85	450	50	400	3,9	12,8
100L2-4	50	85	450	50	400	3,9	12,8
112M-4	50	85	450	50	400	4,8	13,7
132S-4	100	68	640	38	400	3,9	15,5
132M-4	100	68	640	38	400	4,3	16,0
160M-4	150	80	730	40	450	5,0	18,2
160L-4	150	80	730	40	450	5,3	18,6
71M2-6	4	18	160	12	130	1,6	3,8
80M1-6	8	55	300	40	250	2,1	5,9
80M2-6	8	55	300	40	250	2,2	6,0
90S-6	16	55	300	40	250	2,5	6,3
90L-6	16	55	300	40	250	2,7	6,5
100L-6	50	85	450	50	400	2,6	8,6
112M-6	50	85	450	50	400	3,1	9,0
132S-6	100	68	640	38	400	2,3	10,1
132M1-6	100	68	640	38	400	2,4	10,2
132M2-6	100	68	640	38	400	2,6	10,4
160M-6	150	80	730	40	450	3,3	12,1
160L-6	150	80	730	40	450	3,5	12,4
71M2-8	4	18	160	12	130	1,1	2,7
80M1-8	8	55	300	40	250	1,5	4,3
80M2-8	8	55	300	40	250	1,6	4,4
90S-8	16	55	300	40	250	1,4	4,3
90L-8	16	55	300	40	250	1,5	4,4
100L1-8	50	85	450	50	400	1,8	6,3
100L2-8	50	85	450	50	400	1,8	6,3
112M-8	50	85	450	50	400	2,1	6,5
132S-8	100	68	640	38	400	1,6	7,4
132M-8	100	68	640	38	400	1,7	7,5
160M1-8	150	80	730	40	450	1,8	8,5
160M2-8	150	80	730	40	450	2,1	8,7
160L-8	150	80	730	40	450	2,3	8,9

Size	Nominal torque	Link time	Link time	Response delay	Response delay	After-run - DC side - disconnection	AC side - disconnection
CD...SM(N) Y2, Y3, Y	[Nm]	t1 = [ms]	t1 ~ [ms]	t11 = [ms]	t11 ~ [ms]	Revolutions	Revolutions
80M1-2	8	55	300	40	250	9	20
80M2-2	8	55	300	40	250	10	21
90S-2	16	55	300	40	250	8	20
90L-2	16	55	300	40	250	9	21
100L-2	50	85	450	50	400	8	26
112M-2	50	85	450	50	400	10	27
132S1-2	100	68	640	38	400	8	31
132S2-2	100	68	640	38	400	9	32
160M1-2	150	80	730	40	450	10	36
160M2-2	150	80	730	40	450	11	38
160L-2	150	80	730	40	450	12	38
80M2-4	8	55	300	40	250	4	8
90S-4	16	55	300	40	250	4	10
90L-4	16	55	300	40	250	4	10
100L1-4	50	85	450	50	400	4	13
100L2-4	50	85	450	50	400	4	13
112M-4	50	85	640	38	400	5	17
132S-4	100	68	640	38	400	4	16
132M-4	100	68	640	38	400	5	16
160M-4	150	80	730	40	450	5	19
160L-4	150	80	730	40	450	6	19
90S-6	16	55	300	40	250	3	7
90L-6	16	55	300	40	250	3	7
100L-6	50	85	450	50	400	3	9
112M-6	50	85	450	50	400	4	9
132S-6	100	68	640	38	400	3	11
132M1-6	100	68	640	38	400	3	11
132M2-6	100	68	640	38	400	3	11
160M-6	150	80	730	40	450	4	13
160L-6	150	80	730	40	450	4	13
100L1-8	50	85	450	50	400	2	7
100L2-8	50	85	450	50	400	2	7
112M-8	50	85	450	50	400	3	7
132S-8	100	68	640	38	400	2	8
132M-8	100	68	640	38	400	2	8
160M1-8	150	80	730	40	450	3	9
160M2-8	150	80	730	40	450	3	9
160L-8	150	80	730	40	450	3	10

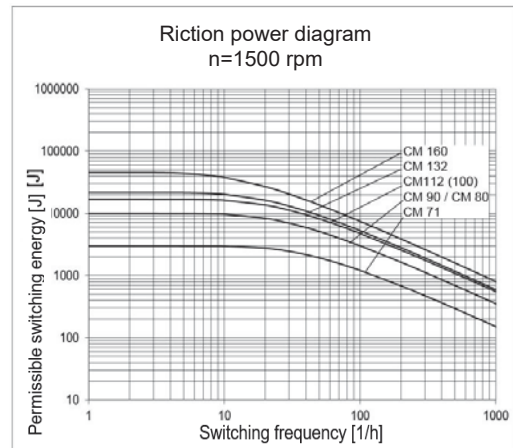
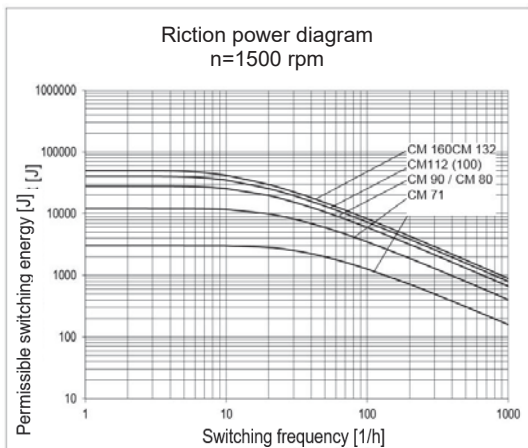

### Type series ...SV and ...SVN

For flange motors of size 180 to 280, e.g. type B5 or B14, it is recommended to fit this brake directly to the drive-side shaft end and the flange of the motor.

The brake then has the IEC connection dimensions for the shaft and flange that are suitable for the motor size for attaching the work machine (type ... SV).

With foot-mounted motors, it is advisable to fit the brake to a reinforced fan guard at the non-drive side of the motor (type ... SVN).

This brake is available in the following versions

- Size 180 - 225 only 4,6,8 pole or 2-pole S3 40 %,
- Size 250 - 280 only 4,6,8 pole
- Terminal compartment Ex d
- 250 to 1200 Nm depending on size
- Standard assignment see page 143
- 24 to 690 VAC 1~, 50/60 Hz, 24 to 300 VDC
- Category 2G /2D/ 2GD
- Protection class Ex d/ Ex tb Protection group IIB/ IIC
- Temperature class T3/T4/T5
- Maximum surface temperature T200 °C/T135°C/T100 °C
- Protection class IP66
- Ambient temperature -20 to +40 °C/-50 to +55°C
- Thermal protection via thermoswitch (optional additional PTC thermistor)
- Manual release (optional; not for 250/280)
- Microswitch (optional)
- Anti-condensation heating (optional)
- Special flange or special shafts by request
- Other versions by request.



Motor with attached brake type CD...SV

### Series ...S

This brake is always fitted to a reinforced fan guard at the non-drive side of the motor. It has the following characteristics:

- Size 180 - 200
- Terminal compartment Ex e
- 72 - 270 Nm depending on size (for standard assignment see page 111)
- 110 to 400 VAC 1~, 50/60 Hz, 12 to 356 VDC
- Category 2 G / 2D / 2GD
- Protection class Ex de / Ex tb
- Protection group IIC
- Temperature class T5
- Maximum surface temperature T100 °C
- Protection class IP67
- Ambient temperature -20 to +40 °C
- Thermal protection via thermoswitch
- Manual release (optional)
- Microswitch (optional)

Other versions by request.



Motor with attached brake type CD...S

**Type series BD...Y3B****Structural design**

With sizes 80-132, the brake is installed in a flameproof enclosure and joined with the motor to form a single unit at the N side. The ignition protection type is II 2G Ex d(e) IIB + H2T4 or II 2D Ex tD A21 IP65 T120°C.

The system is maintenance-free until the brake pads wear out.

**Connection**

The brake coil is excited by a silicon rectifier, which is accommodated inside the ignition-proof enclosure. The brake is switched at the AC or DC side.

For DC-side disconnection, a brake coil connection is led into the terminal compartment. A protective resistor is also built into the motor. If this version is to be used for AC-side switching of the brake, the connection in the terminal box is not required. Instead, the connection shown in the circuit diagram must be made. For pole-changing and inverter-fed motors, the brake coil must be supplied from an external voltage source.

**Motor voltages**

Sizes 80-112: 230 V to 690 V

Size 132: 400 V to 690 V

**Brake voltages**

For coil data, see page 117. Special voltages at additional cost.

**Protective devices**

As protection for the motor, in accordance with EN 60 079-14, VDE 0165 against non-permissible heating, 3 PTC thermistor temperature sensors connected in series are installed in the winding head (warmest point) of the 3 strands of the stator winding.

Each motor is also fitted with a PTC thermistor temperature sensor in the brake coil and on the end shield at non-drive side.

All temperature sensors are connected in series and protect the motor and brake from overloading and excessive heating.

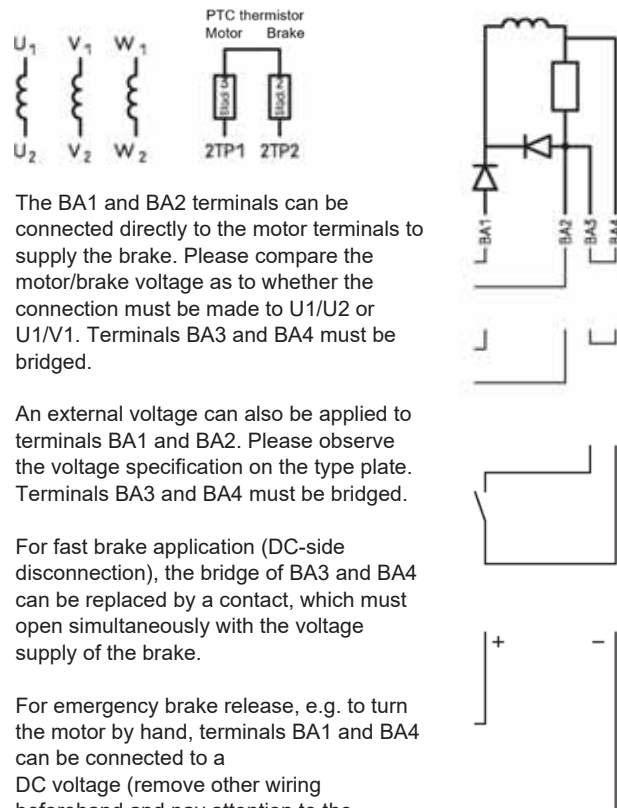
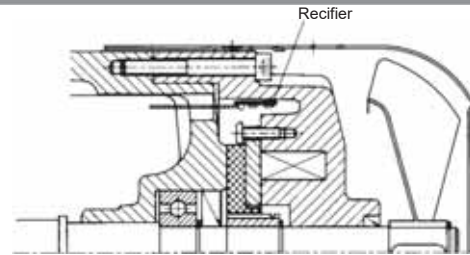

The BA1 and BA2 terminals can be connected directly to the motor terminals to supply the brake. Please compare the motor/brake voltage as to whether the connection must be made to U1/U2 or U1/V1. Terminals BA3 and BA4 must be bridged.

An external voltage can also be applied to terminals BA1 and BA2. Please observe the voltage specification on the type plate. Terminals BA3 and BA4 must be bridged.

For fast brake application (DC-side disconnection), the bridge of BA3 and BA4 can be replaced by a contact, which must open simultaneously with the voltage supply of the brake.

For emergency brake release, e.g. to turn the motor by hand, terminals BA1 and BA4 can be connected to a DC voltage (remove other wiring beforehand and pay attention to the polarity).

Voltage  $U = U_{\sim} \times 0.45$ .

Voltage  $U_{\sim}$  see rated voltage on nameplate.

**Operating data**

The electrical values of the motors which are not mentioned in the operating data (page 113), particularly the magnitudes and the trend of the torques, can be found in the data for three-phase motors (see page 62 ff.).

**Switching times, after-run revolutions**

Guide values for the response and recovery times and also the afterrun revolutions after switching off are listed in the table on the following page, and were obtained from series measurements.

Size	Response time AC side disconnection	DC side disconnection	Disconnection time	After-run <sup>1)</sup> AC side disconnection	DC side disconnection
	t11 ~ [ms]	t11 = [ms]	t2 = [ms]	Revolutions	Revolutions
BD...Y3B					
90S-2	300	50	150	19	3
90L-2	300	50	150	19	3
100L-2	300	50	150	24	3
112M-2	350	50	230	25	4
132S1-2	350	50	230	25	4
132S2-2	350	90	230	27	4
80M1-4	250	45	110	5	1
80M2-4	250	45	110	5	1
90S-4	300	50	150	6	1
90L-4	300	50	150	7	1
100L1-4	300	50	170	11	1
100L2-4	300	50	170	11	1
112M-4	350	90	230	12	2
132S-4	350	90	230	12	2
132M-4	350	90	230	13	2
80M1-6	250	45	110	4	1
80M2-6	250	45	110	4	1
90S-6	300	50	150	6	1
90L-6	300	50	150	6	1
100L-6	300	50	150	7	1
112M-6	350	90	230	7	1
132S-6	350	90	230	7	1
132M1-6	350	90	230	8	2
132M2-6	350	90	230	8	2
80M1-8	250	45	110	2	1
80M2-8	250	45	110	2	1
90S-8	300	50	150	3	1
90L-8	300	50	150	3	1
100L1-8	300	50	150	3	1
100L2-8	300	50	150	4	1
112M-8	350	90	230	6	2
132S-8	350	90	230	7	2
132M-8	350	90	230	7	2

**Notes**

<sup>1)</sup> The after-run of the motors was measured without additional flywheel mass.

**Brake components, wear values**

The adjacent braking torques can be set by combining different pressure springs and brake disks (see table).

**Braking torques<sup>1)</sup>, wear values**

Size	Nominal torque M <sub>2</sub> [Nm]	Wear value		Brake disk Thickness new [mm]
		Q <sub>r</sub> 0,1 [J]	Q <sub>r</sub> ges [J]	
BD...Y3B				
80	16	100x10 <sup>6</sup>	500x10 <sup>6</sup>	8
	20 <sup>2)</sup>	100x10 <sup>6</sup>	500x10 <sup>6</sup>	8
	23	20x10 <sup>6</sup>	20x10 <sup>6</sup>	8
	32	20x10 <sup>6</sup>	20x10 <sup>6</sup>	8
	90	32	130x10 <sup>6</sup>	600x10 <sup>6</sup>
90	40	130x10 <sup>6</sup>	600x10 <sup>6</sup>	10,4
	46 <sup>2)</sup>	30x10 <sup>6</sup>	45x10 <sup>6</sup>	10,4
	64	30x10 <sup>6</sup>	45x10 <sup>6</sup>	10,4
	100	32	130x10 <sup>6</sup>	600x10 <sup>6</sup>
100	40	130x10 <sup>6</sup>	600x10 <sup>6</sup>	10,4
	46 <sup>2)</sup>	30x10 <sup>6</sup>	45x10 <sup>6</sup>	10,4
	64	30x10 <sup>6</sup>	45x10 <sup>6</sup>	10,4
	112	60	130x10 <sup>6</sup>	700x10 <sup>6</sup>
112	75	130x10 <sup>6</sup>	700x10 <sup>6</sup>	11,15
	86 <sup>2)</sup>	65x10 <sup>6</sup>	130x10 <sup>6</sup>	11,15
	100	65x10 <sup>6</sup>	130x10 <sup>6</sup>	11,15
132	60	130x10 <sup>6</sup>	700x10 <sup>6</sup>	11,15
	75	130x10 <sup>6</sup>	700x10 <sup>6</sup>	11,15
	86 <sup>2)</sup>	65x10 <sup>6</sup>	130x10 <sup>6</sup>	11,15
	100	65x10 <sup>6</sup>	130x10 <sup>6</sup>	11,15

**Notes:**

<sup>1)</sup> Tolerance -20 %/+40 % at 1m/s friction speed

<sup>2)</sup> Standard torque

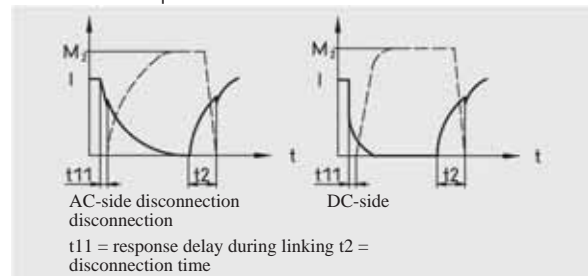

The possible friction work Q<sub>r</sub> can be calculated according to the following formulas. The wear limits can be found in the table.

$$Q_r = \frac{J \times n^2}{182,4} \times \frac{M_2}{M_v} \quad [\text{J}]$$

$$M_v = M_2 + [-]^* M_L$$

Q<sub>r</sub> [J] = available friction work per braking operation  
 Q<sub>r</sub> 0.1 [J] = Friction work per 0.1 mm wear  
 Q<sub>r</sub> tot [J] = Friction work until brake disk replacement  
 J [kgm<sup>2</sup>] = Mass moment of inertia  
 n [rpm] = Speed  
 M<sub>2</sub> [Nm] = Nominal torque  
 M<sub>v</sub> [Nm] = Deceleration torque  
 M<sub>L</sub> [Nm] = Load torque

\* Sign in brackets [-] applies with load braked downwards

# Three-phase asynchronous motors with integrated frequency converter

46

Compact drives

## Type series CD...I Y3 and CD...I

Compact drives with ignition protection type II 2G Ex db eb IIC T4 or II 2D Ex tb IIIC T120°C Db consist of a flameproof motor, type CD..., with an attached frequency inverter, type CEIGL, which is also in a flameproof enclosure. It is suitable for speed-controlled applications in potentially explosive areas in zones 1 and 21.

### Frequency range

The approval covers a frequency range from 2 to 100 Hz. Compact drives can therefore be used for drive solutions up to 6000 rpm. Above 50 Hz, the drive is designed for operation in the field weakening range, i.e. with constant output.

### Monitoring

Thermal monitoring of the motor and the inverter is carried out by PTC thermistor temperature sensors. A certified PTC triggering device and a line contactor are optionally installed in the converter housing. In the event of a fault, the compact drive with galvanic isolation can therefore provide the necessary circuitry for use in potentially explosive areas without additional switchgear.

### Frequency inverter

A frequency inverter from LENZE, type i550 with full power spectrum is used. This operates the motor with field-oriented vector control and a clock frequency of 4 kHz. This results in very good concentricity and control characteristics over the entire speed and torque range. The adaptation of the inverter to the motor with recording of the motor parameters as well as basic parameterization of the frequency inverter is already carried out during the final test.

### Control

The compact drive is controlled via different, interchangeable frequency inverter function modules, depending on the operator's specifications. These function modules are available for bus systems such as PROFIBUS-DP, Applications I/O, Profibus with standard I/O or as I/O modules for conventional control via an analog setpoint and ON/OFF contacts.



Compact drive

### Technical data

<b>Ignition protection type</b>	<b>Flameproof enclosure / dust protection</b> II 2G Ex db eb IIC T4 Gb II 2D Ex td IIIC T120 °C Db
<b>Type examination certificate</b>	
<b>Inverter housing</b>	<b>PTB 08 ATEX 1111X</b>
Sizes	80 to 132
Supply voltage	AC 340 V to 528 V, 45 Hz to 65 Hz
Output range	0.55 to 5.5 kW (FI 1.5 to 5.5 kW)
Maximum current	150 % In for 60 s in 10 min
Leakage current against PE (according to DIN EN 50178)	> 3.5 mA Fixed installation required, with double PE
Output frequency	2 to 50/100 Hz
Frequency resolution absolute	0.02 Hz
Protective insulation from Control circuits	Safe isolation PELV in accordance with DIN EN 50178
EMC	Compliance with the requirements in accordance with EN 61000-3-2

### EMC

Operation on public networks is permitted for 1.5-5.5 kW inverters without further measures. This means that the compact drive fulfils the requirements of the EMC Directive 2014/30/EU and the Low Voltage Directive 2014/35/EU, i.e. conformity with DIN EN 61800-3/A11 and adherence to limit value class A in accordance with DIN EN 55011.

**Connections**

The power supply and control connections are made in an Ex e terminal compartment of the inverter housing. A handheld terminal with keypad and LCD display is available for displaying operating data, parameterization and diagnostics. This "keypad" is connected to the frequency inverter via a connector in the Ex d compartment, where it is accessible via the screw connection in the M63 housing. However, it is not Ex-protected and is therefore only intended for short-term commissioning.



Compact driver terminal compartment

**Power supply line entry**

Size	80	90	100	112
Threaded outlet for cable	2x M25x1,5			
outer -Ø mm	1x M16x1,5	8-17		
		6-11		

Due to the compact connection of a motor with Frequency inverters for use in almost all potentially explosive areas, the user has the following advantages:

- Approval in accordance with ATEX and IECEx allows use in zones 1 and 21 throughout Europe – without further national approvals.
- Simplified planning process
- No additional project planning of control cabinet and switchgear
- Cost reduction due to short supply cable to the motor, a design with shielded cables is not required.
- Supply line to the compact drive without EMC problems by using mains and EMC filters on the motor.
- Fewer individual parts and therefore cost reduction by using one converter wide voltage unit for a mains voltage of 400 V to 480 V.
- No design restrictions, since an Ex d motor with a flameproof enclosure in list version is used.
- The version as a universal chemical motor is possible. Tables with operating data can be found on page 118.

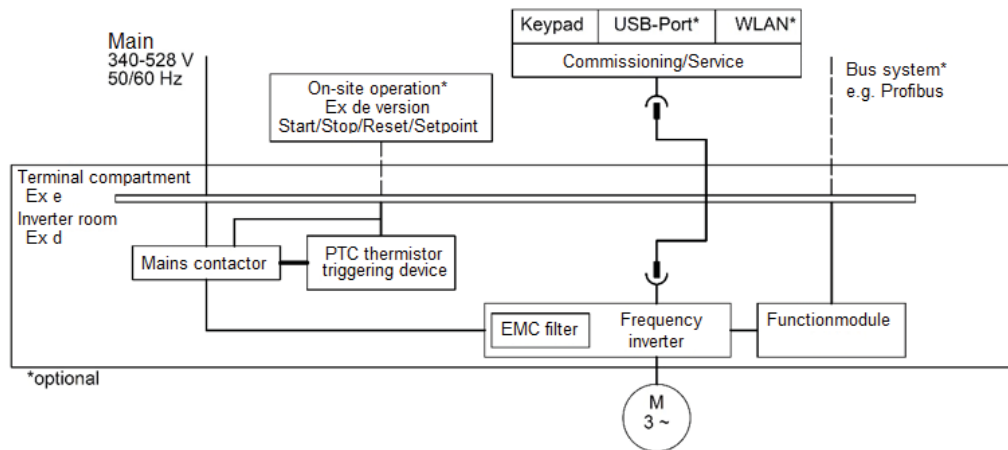

Functional diagram

## Series CD...H

The high-voltage three-phase motors are explosion-protected in the "flameproof enclosure" ignition protection type in accordance with DIN EN 60079-1 for groups IIC and temperature classes T3 to T6.

## Winding

Depending on the design, round wire mesh windings or conventional preformed coils are used. The thermal utilization corresponds to thermal class B. Only in special cases is the class F limit slightly exceeded.

## Version

- Series CD 355...H to CD 450...H
- Acceptance for category II 2G for use in zones 1 and 2
- Acceptance for category II 2D for use in zones 21 and 22
- Temperature class T3 to T6
- Output range from 160 to approx. 700 kW (in relation to 1500 rpm)
- Rated voltage from 3 kV to 6.6 kV
- 50 Hz for 2- to 8-pole and 60 Hz for 4- to 8-pole
- Self-cooling (IC411) with direction of rotation-independent fans
- Low-noise version with direction of rotation-dependent axial fans
- Anti-condensation heating
- Low temperature of up to -55 °C without heating
- Ambient temperatures of up to 60 °C
- Installation altitudes above 1000 m above sea level
- Installation of temperature sensors such as PT 100, PTC thermistors or KTY in windings and bearings as additional protection

Customized special versions Tables with operating data can be found on page 115.



High voltage motor Ex d IIC

### Connection

The motors are connected optionally via terminal boxes with ignition protection type "increased safety" or "flameproof enclosure" for a rated voltage of up to 6.6 kV. The box is located at the top in the standard. Lateral versions are possible. The boxes can each be rotated by  $4 \times 90^\circ$  to allow connection from any direction. This is possible without turning the connection terminals.

The neutral point can be routed to a second terminal compartment by request. The main and star point boxes are then arranged on a flameproof encapsulated intermediate connecting piece, which is mounted on the motor connecting piece.

Because of the fact that the terminals can be exchanged between the two boxes, dual voltage is also possible.

### Bearing

All high-voltage motors are equipped with an insulated bearing at the counter-drive side.

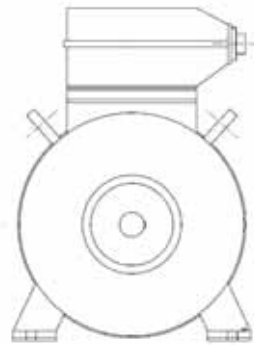

Standard version

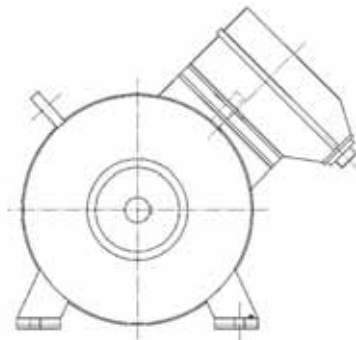

Version with main terminal chamber less than  $45^\circ$

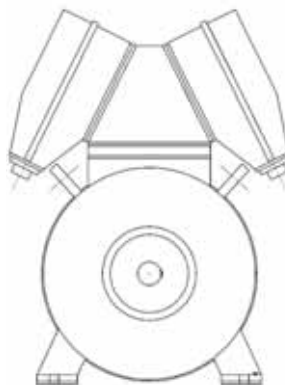

Version with main and neutral point terminal compartment

## Protective device

In accordance with IEC/EN 60079-14, VDE 0165-1, the motors must be protected at all poles against non-permissible heating due to overloading by motor protection switches or equivalent devices.

An equivalent protective device is, for example, winding temperature monitoring using PTC thermistor temperature sensors in accordance with DIN 44081 in combination with an approved tripping device. 2-pole and 4-pole motors up to 200 kW, 6-pole motors up to 160 kW and 8-pole motors with 132 kW can be equipped with such a device for protection.

Temperature sensors for additional motor protection as well as the motor circuit breaker can be used for all motors.

Protection by temperature monitoring alone is mandatory for all operating modes deviating from S1 operation such as inverter operation, short-term operation, switching operation, long-term start-up etc. It also provides protection in the event of reduced cooling air flow and excessive ambient temperature. Motors certified for S1 to S7 as well as S9 and S10 operating modes with temperature sensors for protection are therefore also approved for operation with any frequency inverter (for operating data, see page 62 ff.).

Motors with temperature sensors as additional protection are also generally approved for operation on the frequency inverter. The overload protection is taken care of by the temperature sensor in this case. In this case, the short-circuit protection must be provided by the frequency inverter and/or a motor protection switch.

In the case of protection using temperature sensors, three PTC thermistors connected in series are installed in the winding head (warmest point) of the three strands of the stator winding of the motor. For motors with up to 3 separate windings, 3 temperature sensors are used per winding, all of which are connected in series.

The designations of the temperature sensor terminals in the terminal compartment are .TP1 and .TP2. If the protection is to be provided by the temperature sensors, they must be connected to an approved triggering device marked II(2) G.

Versions with additional temperature sensors, e.g. for prewarning or as reserve, are available by request.

## Stationary heating

Stationary heaters are used to prevent condensation or to protect against motor temperatures of less than -20 °C. Heating to prevent condensate can be implemented via the motor winding or separate heating tapes, and heating for protection against motor temperatures of less than -20 °C is only possible via the motor winding.

## Motor winding

Stationary heating via the motor winding is possible down to -40 °C, and is achieved by feeding via two terminals U1 and V1 with a reduced AC voltage. The specification of the heating voltage in the adjacent table applies to 50 and 60 Hz, with a star or delta motor circuit as well as for all overall lengths of the respective sizes for number of poles  $2p = 2$  to  $2p = 8$ . The specified apparent power is a minimum value, i.e. the next higher unit rating must be selected as the transformer rating. For precise adaptation, voltage taps of  $\pm 10\%$  must be provided on the transformer. It must be ensured that motor voltage and heating voltage cannot be present at the same time.

The heater ratings can be found in the adjacent table.

When using the heater to protect against motor temperatures of less than -20°C, it must be noted that the heater itself is not explosion-proof. It must not be used to heat up the motor from temperatures of less than -20°C to at least -20°C, since the flameproof enclosure loses its approval at motor temperatures of less than -20 °C and therefore does not provide explosion protection. The heater is only suitable for preventing the motor temperature from dropping below -20 °C when stationary.

For applications that require motor temperatures of less than -20 °C (up to max. -55 °C), we provide a specially designed version without a stationary heater, see also page 19.

## Heating tapes

If the heating is designed to protect against condensation, heating tapes protected by temperature switches are used. This ensures that the winding has optimum protection against damage.

Two voltage ranges are available:  
110 V +/- 10 % or 280 V +/- 10 %.

The heater ratings can be found in the adjacent table.

## Stationary heater data

Size	for preventing condensation with heating tape							for protection at temperatures below -20 °C to -40 °C via motor winding						
	Output <sup>1)</sup> per heating tape (total) [W]	via motor winding Output [VA]	Heating voltage					Output [VA]	Heating voltage					
			230 V [V]	400 V [V]	460 V [V]	500 V [V]	690 V [V]		230 V [V]	400 V [V]	460 V [V]	500 V [V]	690 V [V]	
<b>63</b>	28 (28)	25	45	75	90	100	130	65	70	120	140	160	210	
<b>71 (Y)</b>	28 (28)	40	35	65	75	85	110	100	60	100	120	135	175	
<b>80 (Y)</b>	28 (28)	50	30	55	65	75	100	125	50	90	100	115	155	
<b>90 (Y)</b>	28 (28)	70	25	45	50	60	80	175	40	70	80	95	125	
<b>100 (Y)</b>	28 (28)	100	25	40	50	55	70	250	40	65	75	85	115	
<b>112</b>	28 (28)	150	20	40	45	50	65	375	35	60	70	80	105	
<b>132 (Y) und 112 Y</b>	28 (56)	200	20	35	40	45	60	500	30	55	65	70	90	
<b>160 (Y)</b>	28 (56)	300	17	30	35	40	50	750	25	45	55	60	80	
<b>180 (Y)</b>	44 (88)	400	15	25	30	35	45	1000	25	40	50	55	70	
<b>200 (Y)</b>	44 (88)	500	13	20	25	30	40	1250	20	35	40	45	60	
<b>225 (Y)</b>	59 (118)	650	13	20	25	30	40	1650	20	35	40	45	60	
<b>250 (Y)</b>	59 (118)	800		20	25	30	35	2000		35	40	45	60	
<b>280 (Y)</b>	125 (250)	1200		20	20	25	30	3000		30	35	40	50	
<b>315 (Y)</b>	125 (250)	1600		17	20	25	30	4000		30	35	40	50	
<b>355 (Y)</b>	100 (400)	2300		15	18	20	25	5700		25	28	30	40	
<b>400 (Y)</b>	150 (600)	3000		12	14	16	20	7500		20	22	25	30	
<b>450 (Y)</b>	125 (1000)	4000		10	12	13	17	10000		15	18	20	20	

## Notes

1) Output for temperatures as low as -55 °C by request

# Electrical design for motors up to 690 V

## Rated voltage

Explosion-proof, flameproof enclosed three-phase motors are generally available for the following rated voltages:

Rated voltage

<b>50 Hz</b>	230/400 V	Delta/Star <sup>1)</sup>
	400/690 V	Delta/Star <sup>2)</sup>
	500 V	Star <sup>3)</sup>
	500 V	Delta
<b>60 Hz</b>	266/460 V	Delta/Star <sup>1)</sup>
	460 V	Delta <sup>2)</sup>

Notes:

- 1) Standard up to size 112
- 2) Standard from size 132
- 3) Standard tolerances in accordance with IEC/EN 60034-1. Special voltages by request.

## Insulation

All materials used for insulating the winding and the winding leads correspond to thermal class F. Insulation corresponding to thermal class H can be provided at an extra charge by request.

The utilization of the permissible overtemperature limit in continuous operation S1 corresponds to thermal class B for motors with a single-speed design.

Motors in the ...X series with increased power and pole-changing motors are utilized in accordance with thermal class F.

The permissible excess temperature limit for a winding that is insulated in accordance with thermal class F is 105 K at an ambient temperature of 40 °C according to IEC/EN 60034-1.

When utilized in accordance with thermal class B, the permissible winding heating is 80 K at an ambient temperature of 40 °C according to IEC/EN 60034-1. The use of high-quality insulation system materials provides optimal protection against the influence of chemically aggressive gases, vapors, dust, oil and humidity.

## Insulation system

Thermal class in accordance with IEC/EN 60034	Insulation system	Impregnation
F	Wire / surface insulation Enameled wires in accordance with EN 60317-13, Temperature index 200 surface insulating materials based on polyester and aromatic polyamides	Impregnation resins in thermal class F in accordance with DIN EN 60464-2 cured using the continuous impregnation method, using the roller burnishing method from a size of 225

## Winding leads

The motors are given 6 winding leads with the designations U1, V1, W1, U2, V2, W2. In the case of more powerful motors, 2 parallel mains supply lines are required with a delta circuit with a rated current of 400 A or above, due to the permissible current strength of the connecting terminals.

In the case of a delta circuit with 690 A or above and a star circuit with a rated current of 400 A or above, the start of each winding is doubled. The 3 connections of the motor with the 6 connecting terminals then have the designations U, U; V, V; W, W. Here, too, 2 parallel mains supply lines are required in each case.

## Pole-changing motors

The design and dimensions of the pole-changing motors correspond to those of the single-speed three-phase motors. The special features of pole-changing motors are described below.

## Sizes

<b>80–355</b>	4/2-pole
<b>90–355</b>	8/4-pole
<b>90–355</b>	6/4-pole

Other pole number combinations and sizes by request.

In the standard version, the pole-changing motors are designed for approximately the same torque (see page 106 ff.). For motors with a Dahlander circuit, this corresponds to the  $\Delta/YY$  circuit.

For special applications, e.g. fans, centrifugal pumps, etc., the pole-changing motors are designed for approximately quadratic torque (see page 109 ff.). For motors with a Dahlander circuit, this corresponds to the  $Y/YY$  circuit.

The motors are available for rated voltages of 400, 500 and 690 V for a rated frequency of

50 Hz. With special winding, these motors can also be designed for any voltage within the voltage range of 400-690 Volts.

Other voltages and frequencies by request.

The thermal utilization of the motors corresponds to the thermal class "F" that is used.

# Operating characteristics for motors up to 690 V

## Efficiency, power factor

The information in the tables regarding efficiency and power factor apply to operation with rated power, rated voltage and rated frequency. The efficiency values are determined in accordance with IEC/EN 60034-2-1; tolerances in accordance with IEC/EN 60034-1.

Partial load values for the efficiency and the power factor can be found on pages 96 to 101. The values apply to the rated power at 50 Hz.

## Power, operating mode

The performance information in the tables applies to the rated voltage and the rated speed for continuous operation S1 up to a coolant temperature of 40 °C and at installation altitudes of up to 1000 m above sea level.

For higher ambient temperatures and installation altitudes above 1000 m, power reductions are required. The following tables apply to motors with the standard design (temperature class T4).

Coolant temperature [°C]	Reduction of the rated power to about	
40	100%	see „operating data“
45	94%	
50	91%	
55	88%	
60	84%	

Height above sea level [m]	Reduction of the rated power to about	
1000	100%	see „operating data“
1500	97%	
2000	94%	

If the coolant temperature is reduced at installation altitudes of greater than 1000 m above sea level, no power reduction is required in accordance with the allocation in the following table. See also IEC/EN 60034-1.

Installation height above sea level [m]		Highest coolant temperature [°C]
0	bis 1000	40
1000	1500	35
1500	2000	30

Motors with a coolant temperature which deviates from 40 °C and with an installation altitude which deviates from 1000 m above sea level and a modified power allocation compared to the standard version may require additional testing.

Special acceptance tests are also required for operating modes other than S1 in accordance with IEC/EN 60034-1. For this purpose, we request that you provide us with the necessary information in accordance with paragraphs 4 and 6 of these provisions for the design of the motor when you are making inquiries.

Optimum utilization of the motor and safe protection is provided by winding temperature monitoring from PTC thermistors (see page 50).

## Overload, starting current

The motors can be overloaded in accordance with the IEC/EN 60034-1 regulations. They can withstand 1.5 times the rated current for 2 minutes at the operating temperature without damage, and can be loaded with 1.6 times the rated torque for 15 seconds.

The overcurrent relays to be provided in accordance with the installation regulations for electrical systems in hazardous areas only allow limited start-up times. This results in limited mass moments of inertia to be accelerated. The permissible start-up times are shown in the table on page 54. Up to size 315, 2 successive start-ups are possible, and 1 start-up from size 355.

### Starting current, apparent startup power

The values of the starting current as a multiple of the rated current that are specified in the operating data are measured quantities of the type sample. From the values of the starting current ratio, the ratio of the apparent starting power to the rated power of the motor results from the relationship

$$\frac{S_A}{P_2} = I_A/I_N \frac{1}{\eta \times \cos \varphi}$$

### Torque

The motors have squirrel-cage rotors, whose cages are manufactured in accordance with the list in the size range of 63-315L2, 2-pole to 8-pole in die-cast aluminum and also in hard-soldered copper high-bar design and are designed for immediate switch-on. The starting and breakdown torques that occur here - as multiples of the rated-load torques - can be found in the technical tables. The specifications are measured values of the type specimen.

If the voltage deviates from the rated value, the torques (starting torque, the ramp-up torque and the breakdown torque) change approximately in the ratio of the squares of the voltages.

### Direction of rotation

The motors can generally be used for both directions of rotation. Motors with a self-driven axial fan (series ...A, ...AR) are an exception. These fans are dependent on the direction of rotation. The direction of rotation is indicated by an arrow on the fan shroud. Binding wiring diagrams are enclosed with the motors on delivery.

Rated power $P_2$ [kW]	2p = 2 permissible start-up time <sup>1)</sup>		2p = 4 permissible start-up time <sup>1)</sup>		2p = 6 permissible start-up time <sup>1)</sup>		2p = 8 permissible start-up time <sup>1)</sup>	
	cold	warm	cold	warm	cold	warm	cold	warm
	t [s]	t [s]	t [s]	t [s]	t [s]	t [s]	t [s]	t [s]
0,12	-	-	90	62	-	-	100	59
0,18	60	40	90	62	-	-	100	59
0,25	60	40	90	62	80	63	100	59
0,37	60	40	90	62	79	62	100	59
0,55	60	40	90	62	55	40	100	59
0,75	50	36	75	50	85	55	95	56
1,1	47	31	60	38	80	50	108	69
1,5	45	27	46	26	73	42	108	81
2,2	45	20	46	25	65	46	104	72
3	42	20	46	22	51	39	80	50
4	35	19	39	23	46	34	85	55
5,5	30	19	43	25	45	29	84	54
7,5	35	19	42	22	35	22	87	58
11	35	19	39	23	38	19	81	45
15	41	21	46	24	43	22	59	41
18,5	39	20	46	23	46	27	46	29
22	39	20	52	24	43	21	59	40
30	39	20	52	25	60	31	57	33
37	53	21	56	28	57	28	66	45
45	69	32	62	26	75	45	74	44
55	74	29	45	25	80	56	77	48
75	85	39	56	23	64	36	61	40
90	84	42	59	25	49	22	60	30
110	97	45	62	23	60	30	60	30
132	103	48	63	26	60	30	60	30
160	100	50	60	30	60	30	60	30
200	100	50	60	30	60	30	60	30
250	100	50	60	30	60	30	60	30
315	100	50	60	30	60	30	60	30
355	100	50	60	30	60	30	60	30
400	100	50	60	30	60	30	60	30
450	-	-	60	30	60	30	-	-

#### Note

<sup>1)</sup> These times can only be achieved with winding temperature monitoring with PTC thermistor temperature sensors

### Switching frequencies

For motors with the standard design (temperature class T4), the start-ups specified in the table are permissible if heat class "F" is used and the winding temperature is monitored by PTC thermistors.

A distinction is made between:

1. Number of starts against a constant load torque.
2. Number of starts against a load torque the increases quadratically with the speed up to the nominal point.

The specified values apply to the inertia factor  $FI = 1$ , i.e. without taking the external moment of inertia into consideration. The external moments of inertia can be taken into consideration done via the FI-factor, according to the relationship

$$S = \frac{S_{list}}{FI} \text{ [S/h]} \quad \text{with } FI = \frac{J_{add} + J_{mot.}}{J_{mot.}}$$

In contrast to the no-load switching frequency, the switching frequencies specified for the loaded motor are pure ramp-ups.

If the motors are braked by countercurrent, the values must be divided by the K-factor.

This K-factor is:

- K = 2.5 for constant counter torque
- K = 3.2 for quadratically increasing counter torque

This results in the relationship:

$$S = \frac{S_{list} \text{ [S/h]}}{FI \times K}$$

[S/h] Switchings per hour

### Startups per hour

Rated power $P_2$ [kW]	2p = 2		2p = 4		2p = 6		2p = 8	
	Startups per hr. FI = 1		Startups per hr. FI = 1		Startups per hr. FI = 1		Startups per hr. FI = 1	
	Counter torque const.	Counter torque quadr.	Counter torque const.	Counter torque quadr.	Counter torque const.	Counter torque quadr.	Counter torque const.	Counter torque quadr.
	[S/h]	[S/h]	[S/h]	[S/h]	[S/h]	[S/h]	[S/h]	[S/h]
0,12	-	-	11000	12000	-	-	6000	10200
0,18	8000	11000	11000	12000	-	-	6000	10200
0,25	8000	11000	11000	12000	10800	11450	6000	10200
0,37	8000	11000	11000	12000	10800	11450	5000	8500
0,55	8000	11000	10800	11500	10800	11450	5000	8500
0,75	7850	10500	10800	11550	6300	10590	4000	6800
1,1	5700	7560	6200	9550	5900	8880	6100	9900
1,5	3260	4410	3420	6480	2950	4580	9200	10500
2,2	1410	1960	2960	4400	2800	4100	4500	6930
3	980	1260	1930	2690	2600	3780	3900	5500
4	820	1200	2600	3490	2400	3460	2750	4530
5,5	610	880	1520	2050	2300	3150	2420	3480
7,5	780	1040	1000	1360	1340	1800	2190	3180
11	300	400	990	1360	720	1000	1100	1640
15	240	320	510	750	630	860	1330	1850
18,5	180	240	460	620	540	820	770	1040
22	130	170	130	180	400	540	1080	1430
30	65	100	300	400	290	380	410	560
37	55	75	230	310	170	240	370	560
45	50	65	110	170	200	280	205	305
55	40	55	95	130	220	310	270	305
75	30	45	70	100	100	170	220	330
90	25	35	40	65	90	150	120	180
110	18	27	23	30	80	125	170	230
132	16	25	30	55	70	100	150	190
160	12	22	30	45	55	85	150	190
200	8	20	22	35	50	75	150	190
250	8	18	18	30	40	60	-	-
315	8	18	18	30	-	-	-	-

#### Notes

Size 355 to 450 by request  
 Switching operation can only take place if there is winding temperature monitoring using a PTC thermistor temperature sensor.

### Frequencies above the nominal frequency of 50 Hz

If the frequency is increased further above the nominal point of the drive, appropriately faster speeds will occur.

The speeds corresponding to the maximum frequencies must not exceed the limit speeds of the motors. If the motors are operated above the nominal frequency, attention must be paid to the additional noise development.

To reduce the noise levels, it is advisable to use a motor with externally driven external fan.

For operation above the nominal frequency (50 Hz) there are two basic methods of operation:

### Three-phase motors with operation on a frequency converter with constant flux up to 87 Hz

If the motor is operated above the mains frequency with a voltage that increases linearly with the frequency increase, the magnetic flux remains constant. Due to the disproportionate increase in iron losses with the frequency, the maximum torque is reduced compared to 50 Hz (see torque curve diagrams on pages 58 and 61).

The technical tables contain the power specification in relation to 87 Hz or the maximum frequency with 2-pole motors. When the voltage is being increased linearly with the frequency, make sure that the voltage limits are not exceeded (see permissible voltage stress).

### Three-phase motors when operated on the frequency converter with constant voltage above 50 Hz

If the motor is operated above the mains frequency with constant voltage, field weakening operation is present in this range.

The flux of the motor decreases inversely proportional to the increase in frequency. The power of the motor remains almost constant in the range above the nominal frequency (50 Hz) up to 87 Hz, i.e. the torque decreases in inverse proportion to the frequency (see torque curve on pages 58 and 59).

The maximum frequency for 2-pole motors can be found in the technical tables.

### Power and torques

The power ratings for inverter operation shown in the operating data tables apply to continuous operation S1 at an ambient temperature of up to 40 °C and an installation altitude of up to 1000 m. Power ratings for higher ambient temperatures and installation altitudes are available by request.

The power rating are in relation to inverters with

- DC link (I inverter)
- DC link with block-shaped or pulsed voltage (U inverter)

The thermal utilization of the motors corresponds to the thermal class F that is used.

Torque curves can be found on pages 58 and 59.

### Noise of the three-phase motors during operation at the frequency inverter

With inverter operation, the noise increases due to the harmonics compared to mains operation. The increase is approx. 7-15 dB(A) at the U inverter without using a sinusoidal phase filter, i.e. approx. 3 dB(A) at the I inverter.

With the filter on the U inverter, the noise values at frequencies  $\leq 50$  Hz do not exceed the values with mains operation.

The noise increase for self-ventilated motors and frequencies > 50 Hz is shown in the table below.

Guide values for the increase in sound pressure level due to the increase in fan noise.

F [Hz]	$\Delta$ LP [dB(A)]
50	0
60	$\leq 5$
70	$\leq 9$
80	$\leq 12$
87	$\leq 15$

For low-noise drives with inverters we provide special motors in accordance with page 35.

### Motors with externally driven external fans

Motors with externally driven external fans are preferably used with drives with bigger control ranges and constant counter-torque and for operation above 50 Hz to avoid an increase in noise.

The fan motor corresponds to the "flameproof enclosure" ignition protection type.

The electrical control system must ensure that the main motor can only be operated with the forced cooling switched on.

### Installation note

If the inverter output with current limiting is not galvanically isolated from the mains, the requirements of DIN EN 50178, VDE 0160 (Electronic equipment for use in power installations) must be observed for the overload protection of the protective conductor.

When the protective device in the phase conductors is being dimensioned, it must be taken into consideration that in the event of a fault, the protective conductor current may be greater than the phase conductor current. The protective earth conductor must then be designed for this fault current.

All of the inverter manufacturer's information concerning this error case must be observed.

### Permissible stress load

When the motors are being operated on frequency converters, the switching operations cause voltage peaks which additionally put the terminals and the winding insulation under stress. In an extreme way, this is the case when pulse inverters with very steep edges excite oscillations on the lines, which can also overlap in unfavorable cases.

The following values of the permissible voltage load capacity caused by voltage peaks (limit values of the terminals and the winding insulation) are safely controlled.

1. **Connection terminals** have clearances and creepage distances which are designed for an effective rated voltage of 690 V on the basis of DIN EN 60079-7 - Equipment protection by increased safety "e".  
The permissible transient overvoltage in frequency converter operation of the motors is 2.15 kV phase to phase and phase to ground.
2. **Standard windings** for effective rated voltages of 230/400 V and 500 V have a peak electric strength of 1.6 kV phase to phase and phase to ground with continuous heating in accordance with thermal class F. These motors are suitable for frequency converters without an additional filter.
3. **Standard windings** for an effective rated voltage of 400/690 V have a peak electric strength of 1.6 kV phase to phase and phase to ground with continuous heating in accordance with thermal class F. These motors are suitable for frequency converters with an additional filter.
4. **Special windings** for an effective rated voltage of 690 V have a peak electric strength of 2.15 kV phase to phase and phase to ground with continuous heating in accordance with thermal class F. These motors are suitable for frequency converters without additional filters. They are marked with a "U" at the end of the type designation of the motor. This special winding is available from size 315 and requires a power reduction. The efficiencies correspond to the manufacturer's standard.

# Operation at frequency inverter

Torque curve at frequency inverter, 50 Hz mains  
Temperature class T4  
2p = 2

Diagram 1: Size 63–160

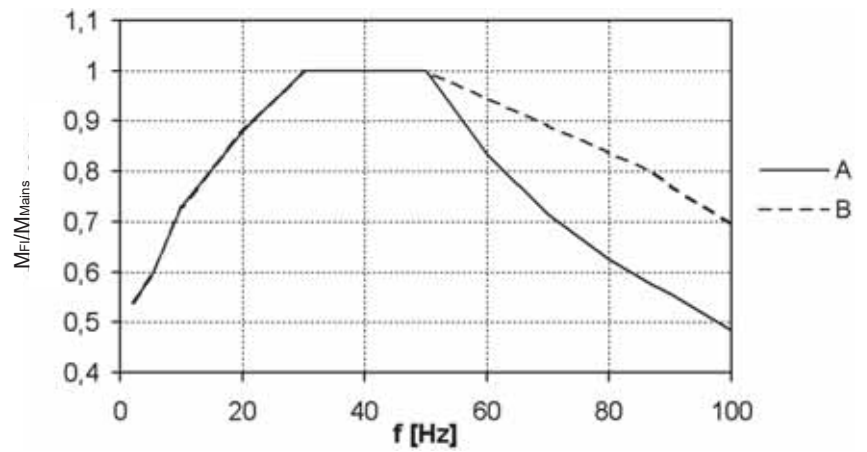

Diagram 2: Size 180–225

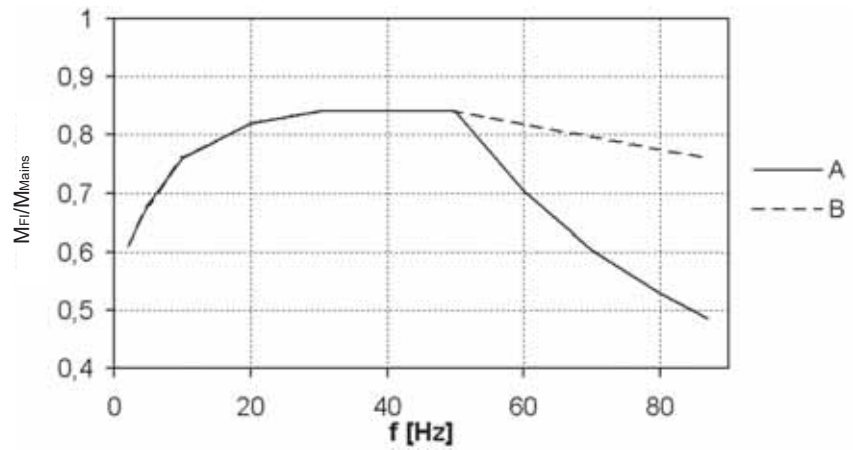
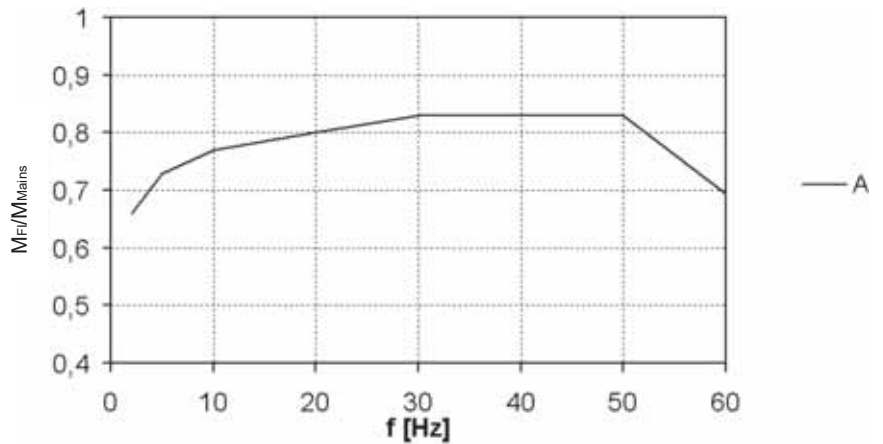

Diagram 3: Size 250–400



Curve A: Field weakening range from 50 Hz  
Curve B: Field weakening range from 87 Hz

Diagram 4: Size 63–160

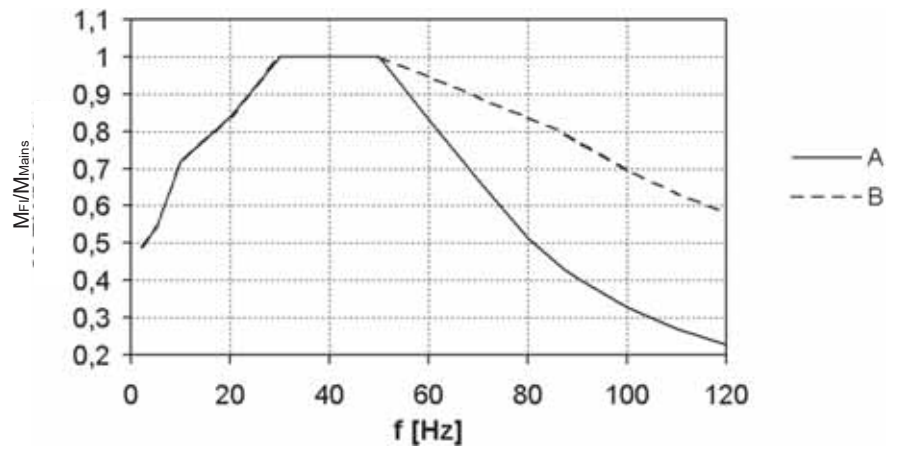

Diagram 5: Size 180–225

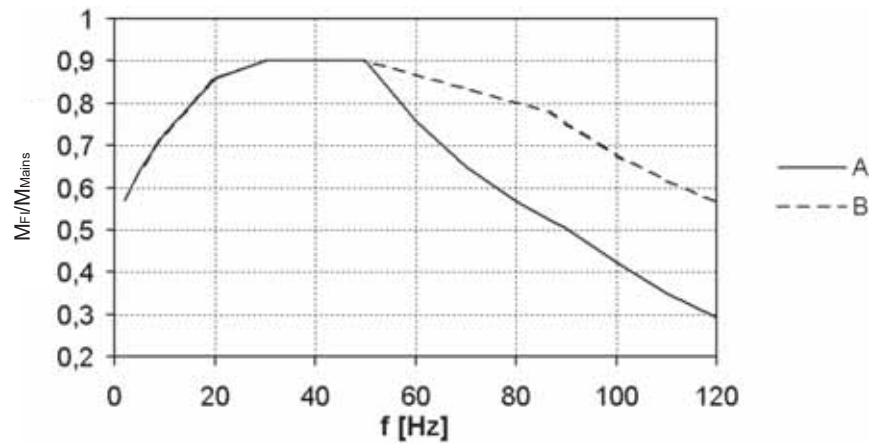
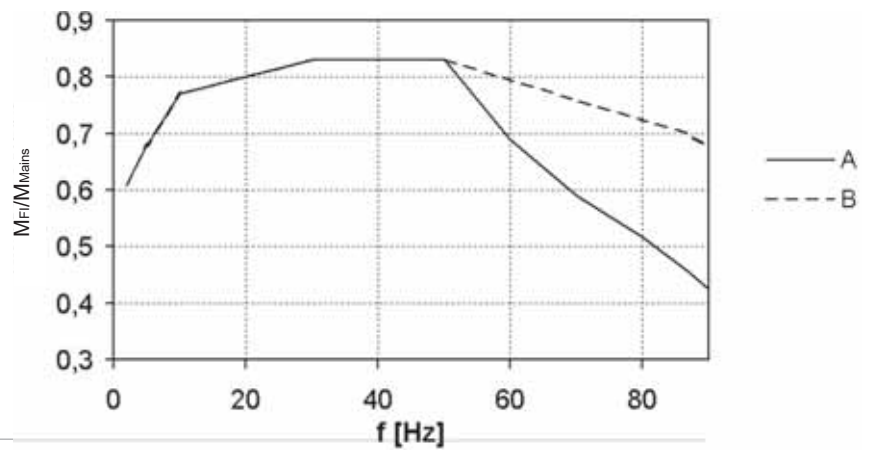

Diagram 6: Size 250–400



Curve A: Field weakening range from 50 Hz  
 Curve B: Field weakening range from 87 Hz

# Operation at frequency inverter

Torque curve at frequency inverter, 60 Hz mains  
Temperature class T4  
2p = 2

Diagram 1: Size 63–160

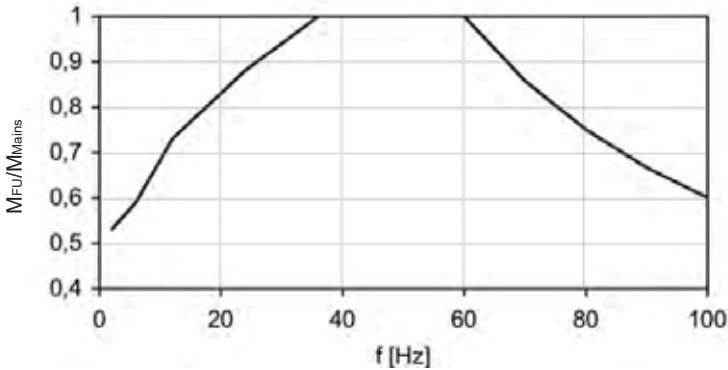

Diagram 2: Size 180–225

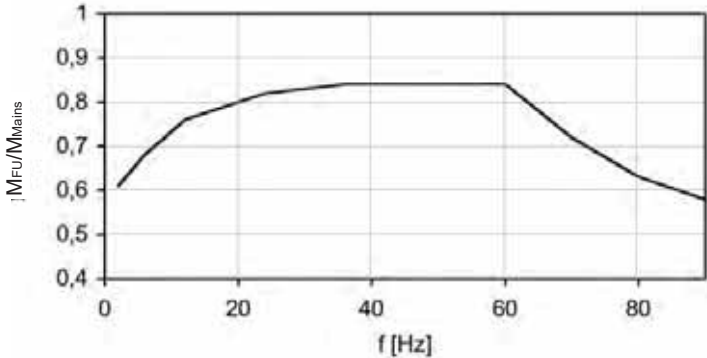
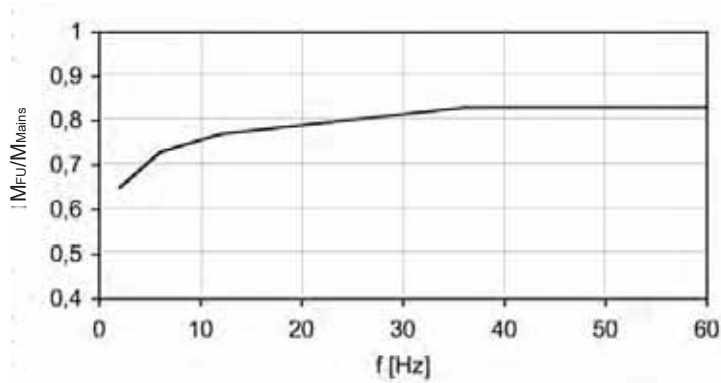

Diagram 3: Size 250–400



Curve A: Field weakening range from 60 Hz

Diagram 4: Size 63–160

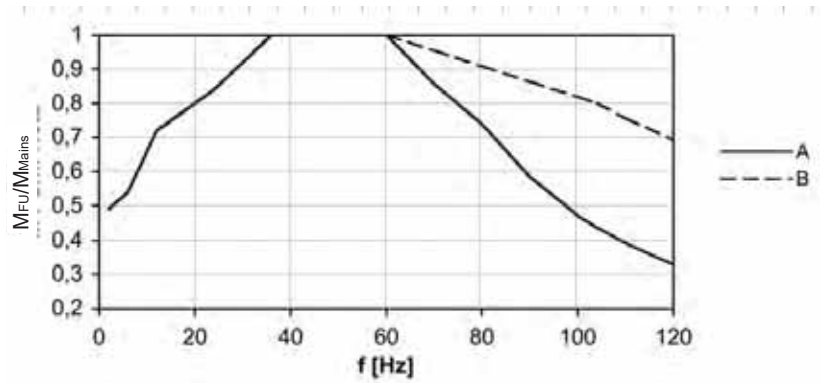

Diagram 5: Size 180–225

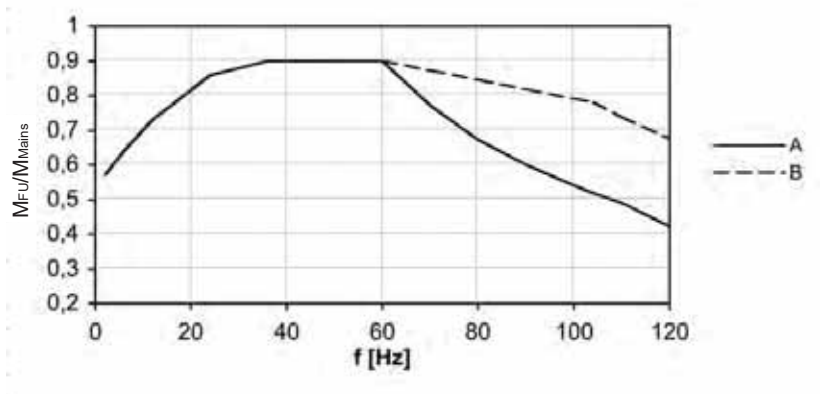
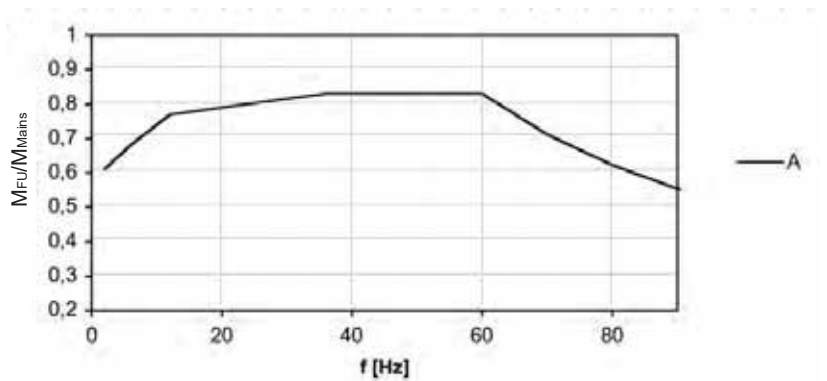

Diagram 6: Size 250–400



Curve A: Field weakening range from 60 Hz  
 Curve B: Field weakening range from 104 Hz

# IE3 Mains operation 50 Hz

Temperature class T4,  
ns = 3000 rpm, 2p = 2

62

Size	Output P <sub>2</sub> [kW]	Rated current at		Speed n [rpm]	Efficiency level η [%]	Performance factor cos φ	Torque M [Nm]	Starting torque M <sub>A</sub> / M <sub>N</sub>	Starting current I <sub>A</sub> / I <sub>N</sub>	Break-down torque M <sub>K</sub> / M <sub>N</sub>	Mass-moment of inertia J [kgm <sup>2</sup> ]	Weight <sup>2)</sup> m [kg]	Noise values with radial fan		Noise values with axial fan	
		400 V I [A]	500 V I [A]										L <sub>P</sub> [dB(A)]	L <sub>W</sub> [dB(A)]	L <sub>P</sub> [dB(A)]	L <sub>W</sub> [dB(A)]
<b>CD...Y3</b>					<b>IE3</b>	<b>Efficiency according to IEC 60034-30</b>										
63M1-2	0.18	0.45	0.36	2835	70	0.83	0.61	3.2	6	4.7	0.00028	16	49	61	-	-
63M2-2	0.25	0.6	0.48	2825	73	0.83	0.85	3.1	5.8	4.5	0.00028	16	49	61	-	-
71M1-2	0.37	0.83	0.66	2825	74	0.87	1.25	2.6	5.7	3.4	0.00058	24	51	63	-	-
71M2-2	0.55	1.17	0.94	2830	78	0.87	1.86	2.7	6.1	3.6	0.00080	25	51	63	-	-
80M1-2	0.75	1.5	1.20	2890	82.8	0.87	2.48	3	6.6	3.6	0.0013	31	55	67	-	-
80M2-2	1.1	2.2	1.74	2885	83.7	0.87	3.64	3.2	7.1	3.5	0.0018	35	55	67	-	-
90S-2	1.5	2.9	2.3	2895	84.7	0.88	4.95	3	6.8	3.5	0.0029	45	60	72	-	-
90L-2	2.2	4.2	3.35	2900	86.4	0.88	7.2	3	6.9	3.6	0.0039	48	60	72	-	-
100L-2	3	5.6	4.45	2910	88.1	0.88	9.8	2.5	6.9	2.9	0.0051	53	63	75	-	-
112M-2	4	7.5	6	2930	88.4	0.87	13	2.8	6.9	3.6	0.0089	95	63	76	55	67
132S1-2	5.5	10	8	2925	89.5	0.89	18	2.5	7	3.3	0.0125	103	63	76	55	68
132S2-2	7.5	13.5	10.8	2930	90.3	0.89	24.4	2.7	7.1	3.5	0.0177	115	63	76	55	68
160M1-2	11	20	16	2940	91.3	0.87	35.7	3	7.3	3.6	0.032	163	66	79	56	69
160M2-2	15	26	21	2940	92	0.9	48.7	2.8	7.2	3.2	0.043	173	66	79	56	69
160L-2	18.5	31.5	25.5	2940	92.5	0.91	60	2.7	7.2	3.1	0.052	188	66	79	56	69
180M-2	22	37.5	30	2945	92.9	0.91	71	2.6	7.5	3.2	0.075	196	69	82	58	71
200L1-2	30	51	41	2955	93.5	0.9	97	2.7	7.5	3.1	0.13	254	71	85	60	74
200L2-2	37	63	51	2955	93.8	0.9	120	2.8	7.6	3.2	0.16	278	71	85	60	74
225M-2	45	77	61	2960	94.2	0.9	145	2.7	7.3	3	0.24	400	72	86	60	74
250M-2	55	96	76	2970	94.4	0.88	177	2.8	7.5	3.1	0.4	545	75	89	64	78
280S-2	75	130	103.8	2975	94.8	0.88	241	2.3	7.1	2.8	0.65	700	76	90	66	80
280M-2	90	157	126	2980	95.1	0.87	288	2.4	7.4	2.9	0.78	762	76	90	66	80
315S-2	110	187	150	2975	95.4	0.89	353	2.2	7.1	2.6	1.4	960	76	91	66	81
315M-2	132	220	177	2975	95.8	0.9	424	2.1	6.8	2.5	1.6	1025	76	91	66	81
315L1-2	160	270	215	2980	95.9	0.9	514	2.4	7.4	2.7	1.7	1065	76	91	66	81
315L2-2	200	335	265	2980	96	0.9	614	2.3	6.9	2.6	2.2	1270	76	91	66	81
315L3-2	250	410 <sup>1)</sup>	325	2980	96	0.92	801	1.7	7.2	2.7	2.8	1420	76	91	66	81
355L1-2	315	510 <sup>1)</sup>	410 <sup>1)</sup>	2980	96.6	0.92	1009	1.5	6.7	2.8	4.5	1900	81	97	68	84
355L2-2	355	570 <sup>1)</sup>	455 <sup>1)</sup>	2985	96.8	0.93	1136	1.4	6.9	2.7	5	2050	81	97	68	84
355L3-2	400	640 <sup>1)</sup>	515 <sup>1)</sup>	2985	96.8	0.93	1280	1.3	7	2.8	5.5	2350	81	97	68	84
400L-2	450	710 <sup>1)</sup>	570 <sup>1)</sup>	2990	97	0.94	1437	1.1	7.2	2.8	8.5	2910	81	97	-	-

**Note:**

- 1) Two parallel supply lines are required
- 2) Type B3 with terminal compartment type EAR

The values are also valid for series BD..

# IE3 Mains operation 50 Hz

Temperature class T4,  
ns = 1500 rpm, 2p = 4

63

Size	Output P <sub>2</sub> [kW]	Rated current at		Speed n [rpm]	Efficiency η [%]	Power factor cos φ	Torque M [Nm]	Starting torque M <sub>A</sub> /M <sub>N</sub>	Starting current I <sub>A</sub> /I <sub>N</sub>	Break down torque M <sub>K</sub> /M <sub>N</sub>	Mass-moment of inertia J [kgm <sup>2</sup> ]	Weight <sup>2)</sup> m [kg]	Noise values with radial fan		Noise values with axial fan	
		400 V I [A]	500 V I [A]										L <sub>P</sub> [dB(A)]	L <sub>W</sub> [dB(A)]	L <sub>P</sub> [dB(A)]	L <sub>W</sub> [dB(A)]
<b>CD...Y3</b>	<b>IE3 Efficiency according to IEC 60034-30</b>															
63M1-4	0.12	0.37	0.29	1430	68	0.69	0.80	3.4	5.3	3.7	0.00046	16	44	56	-	-
63M2-4	0.18	0.51	0.41	1425	72	0.71	1.21	2.8	5.2	3.4	0.00063	17	44	56	-	-
71M1-4	0.25	0.68	0.54	1445	73.8	0.72	1.65	3.1	5.7	3.7	0.00092	24	45	57	-	-
71M2-4	0.37	0.97	0.78	1435	77.5	0.71	2.46	3.6	6.3	3.9	0.0013	25	45	57	-	-
80M1-4	0.55	1.24	0.99	1440	81	0.79	3.65	2.9	6.8	3.5	0.0021	31	46	58	-	-
80M2-4	0.75	1.68	1.34	1445	82.6	0.78	5	3.2	6.8	4.2	0.0029	35	46	58	-	-
90S-4	1.1	2.35	1.89	1455	84.2	0.8	7.2	2.4	6.8	3.1	0.0046	44	49	61	-	-
90L-4	1.5	3.15	2.5	1450	85.5	0.81	9.9	2.5	6.9	3.2	0.0056	46	49	61	-	-
100L1-4	2.2	4.35	3.45	1450	87.1	0.84	14.5	2.9	7.3	3.3	0.011	59	52	64	-	-
100L2-4	3	5.9	4.7	1450	87.8	0.84	18.8	3.1	7.4	3.6	0.011	59	52	64	-	-
112M-4	4	7.8	6.3	1460	88.7	0.83	26.2	3	7.2	3.4	0.022	100	54	66	-	-
132S-4	5.5	10.4	8.3	1460	89.6	0.85	36	3.2	7.1	3.5	0.03	113	57	70	55	68
132M-4	7.5	13.9	11.1	1460	90.5	0.86	49	3.1	7.4	3.3	0.041	125	57	70	55	68
160M-4	11	20.5	16.3	1470	91.5	0.85	71	2.8	7.1	3.1	0.079	184	62	75	59	69
160L-4	15	28.5	22.5	1470	92.1	0.83	97	3.1	7.4	3.4	0.092	208	62	75	59	69
180M-4	18.5	34.5	28	1470	92.7	0.83	120	3.3	7.4	3.4	0.155	217	60	73	57	70
180L-4	22	38.5	32.8	1470	93.2	0.83	143	3.2	7.3	3.4	0.25	244	60	73	57	70
200L-4	30	54	43.5	1470	93.8	0.85	195	3.1	7.6	3.3	0.25	274	61	75	58	72
225S-4	37	67	54	1475	93.9	0.85	240	3	7.1	2.9	0.4	372	63	77	59	73
225M-4	45	80	64	1475	94.3	0.86	291	3.1	7.2	3	0.48	402	63	77	59	73
250M-4	55	95	76	1475	94.6	0.88	356	3.1	7.3	3	0.75	588	65	79	64	78
280S-4	75	134	107	1480	95.2	0.85	484	3	7.4	2.8	1.25	740	68	82	66	80
280M-4	90	160	128	1485	95.3	0.85	579	3.2	7.8	3	1.48	820	68	82	66	80
315S-4	110	198	158	1485	95.6	0.84	707	2.7	6.9	2.7	2.2	1040	69	84	66	81
315M-4	132	235	189	1485	95.8	0.84	849	2.7	7	2.7	2.7	1120	69	84	66	81
315L1-4	160	285	230	1490	96	0.84	1026	2.8	7.4	2.8	3.1	1210	69	84	66	81
315L2-4	200	355	285	1490	96.1	0.85	1286	2.6	6.9	2.6	3.9	1430	69	84	66	81
315L3-4	250	430 <sup>1)</sup>	345	1490	96.2	0.87	1602	1.7	7.3	2.7	4.6	1565	69	84	66	81
355L1-4	315	525 <sup>1)</sup>	420 <sup>1)</sup>	1490	96.3	0.90	2019	1.5	6.9	2.7	6.1	2050	72	88	68	84
355L2-4	355	590 <sup>1)</sup>	470 <sup>1)</sup>	1490	96.6	0.90	2275	1.6	6.9	2.8	6.7	2200	72	88	68	84
355L3-4	400	665 <sup>1)</sup>	530 <sup>1)</sup>	1490	97	0.90	2564	1.5	7	2.8	7.4	2430	72	88	68	84
400M-4	450	735 <sup>1)</sup>	590 <sup>1)</sup>	1495	97	0.91	2875	1.1	7.3	2.7	18	2850	78	94		
400L-4	500	815 <sup>1)</sup>	655 <sup>1)</sup>	1495	97.1	0.91	3194	1.1	7.3	2.7	20	3230	78	94		
450M-4	560	915 <sup>1)</sup>	730 <sup>1)</sup>	1495	97.2	0.91	3577	1	6.8	2.7	26	3500	79	95		
450L-4	630	1025 <sup>1)</sup>	820 <sup>1)</sup>	1495	97.4	0.91	4024	1	6.8	2.7	31	3800	79	95		
500...	by request															

## Note

- 1) Two parallel supply lines are required
- 2) Type B3 with terminal compartment type EAR

The values are also valid for series BD..

# IE3

## Mains operation 50 Hz

Temperature class T4  
ns = 1000 rpm, 2p = 6

64

Size	Output P <sub>2</sub> [kW]	Rated current at		Speed n [rpm]	Efficiency η [%]	Power factor cos φ	Torque M [Nm]	Starting torque M <sub>A</sub> / M <sub>N</sub>	Starting current I <sub>A</sub> / I <sub>N</sub>	Break-down torque M <sub>K</sub> / M <sub>N</sub>	Mass moment of inertia J [kgm <sup>2</sup> ]	Weight <sup>2)</sup> m [kg]	Noise values with radial fan		
		400 V I [A]	500 V I [A]										L <sub>P</sub> [dB(A)]	L <sub>W</sub> [dB(A)]	
<b>CD...Y3</b>					<b>IE3</b>		<b>Efficiency according to IEC 60034-30</b>								
<b>71M2-6</b>	0.25	0.75	0.60	935	69	0.70	2.55	2.5	4.4	3.2	0.0025	25	44	56	
<b>80M1-6</b>	0.37	1.02	0.82	950	73.8	0.71	3.70	1.7	4.4	3	0.0033	31	44	56	
<b>80M2-6</b>	0.55	1.41	1.12	945	77.4	0.73	5.3	1.8	4.5	3.1	0.0046	35	44	56	
<b>90S-6</b>	0.75	1.96	1.56	955	79.1	0.70	7.5	2.7	5.5	3.1	0.0080	44	47	59	
<b>90L-6</b>	1.1	2.7	2.15	955	81.4	0.72	11	2.8	5.9	3.1	0.0095	46	47	59	
<b>100L-6</b>	1.5	3.65	2.9	965	83.5	0.71	14.8	3	6.8	3.3	0.017	59	50	62	
<b>112M-6</b>	2.2	4.75	3.8	965	85.5	0.78	21.8	2.6	6.8	3.1	0.031	100	53	65	
<b>132S-6</b>	3	6.8	5.5	970	85.7	0.74	29.5	3.2	7.1	3.7	0.031	100	56	69	
<b>132M1-6</b>	4	8.7	7	965	87	0.76	39.6	2.9	6.9	3.7	0.037	104	56	69	
<b>132M2-6</b>	5.5	11.5	9.2	965	88.3	0.78	54	2.9	7.2	3.7	0.048	117	56	69	
<b>160M-6</b>	7.5	14.4	11.5	970	89.4	0.84	74	2.8	7.5	3.8	0.12	190	58	71	
<b>160L-6</b>	11	21	16.7	975	90.5	0.84	108	3	7.6	3.9	0.14	220	58	71	
<b>180L-6</b>	15	29	23	975	91.5	0.82	147	2.7	7.4	3.8	0.19	215	58	71	
<b>200L1-6</b>	18.5	35	28	975	92	0.83	181	2.5	7	3.5	0.28	270	58	71	
<b>200L2-6</b>	22	41	32.5	975	92.4	0.84	215	2.2	6.9	3.2	0.31	280	58	72	
<b>225M-6</b>	30	56	45	985	93	0.83	291	3	6.9	2.7	0.69	404	58	72	
<b>250M-6</b>	37	69	55	985	93.5	0.83	359	3	6.8	2.7	1.03	570	58	76	
<b>280S-6</b>	45	84	67	990	93.9	0.82	434	2.8	6.6	2.4	1.35	720	62	77	
<b>280M-6</b>	55	104	83	985	94.4	0.81	533	2.8	6.5	2.4	1.7	770	62	77	
<b>315S-6</b>	75	130	104	990	94.9	0.88	723	3	7.2	2.7	4.3	995	65	79	
<b>315M-6</b>	90	155	124	990	95.2	0.88	868	3.2	7.7	2.8	5	1050	65	79	
<b>315L1-6</b>	110	189	151	990	95.5	0.88	1061	3.3	7.8	2.8	6	1145	69	84	
<b>315L2-6</b>	132	225	181	990	95.6	0.88	1273	3.2	7.7	2.8	7.3	1265	69	84	
<b>315L3-6</b>	160	275	220	990	95.8	0.88	1543	3.3	7.8	2.8	8.3	1440	69	84	
<b>355M-6</b>	200	345	275	990	95.9	0.87	1929	1.8	6.7	2.7	11.3	1750	74	90	
<b>355L1-6</b>	250	430 <sup>1)</sup>	345	990	95.9	0.88	2411	1.8	6.7	2.7	13.8	1950	74	90	
<b>355L2-6</b>	315	540 <sup>1)</sup>	430 <sup>1)</sup>	990	96	0.88	3039	1.7	6.9	2.6	17.6	2300	74	90	
<b>400M-6</b>	355	595 <sup>1)</sup>	475 <sup>1)</sup>	994	96.6	0.89	3411	1.1	6.6	2.7	27	2850	78	94	
<b>400L-6</b>	400	670 <sup>1)</sup>	535 <sup>1)</sup>	994	96.6	0.89	3843	1.1	6.8	2.6	31	3230	78	94	
<b>450M-6</b>	450	755 <sup>1)</sup>	605 <sup>1)</sup>	995	96.6	0.89	4319	1.2	6.8	2.8	46	3500	78	94	
<b>450L-6</b>	500	835 <sup>1)</sup>	670 <sup>1)</sup>	995	97	0.89	4799	1.1	6.8	2.7	51	3800	78	94	
<b>500..</b>	by request														

**Note:**

- 1) Two parallel supply lines are required
- 2) Type B3 with terminal compartment type EAR

The values are also valid for series BD..

# IE3 Mains operation 50 Hz

Temperature class T4  
ns = 750 rpm, 2p = 8

65

Size	Output P <sub>2</sub> [kW]	Rated current at		Speed n [rpm]	Efficiency η [%]	Power factor cos φ	Torque M [Nm]	Starting torque M <sub>A</sub> / M <sub>N</sub>	Starting current I <sub>A</sub> / I <sub>N</sub>	Break-down torque M <sub>K</sub> / M <sub>N</sub>	Mass moment of inertia J [kgm <sup>2</sup> ]	Weight <sup>2)</sup> m [kg]	Noise values with radial fan	
		400 V I [A]	500 V I [A]										L <sub>P</sub> [dB(A)]	L <sub>W</sub> [dB(A)]
<b>CD...Y3</b>	<b>IE3 Efficiency according to IEC 60034-30</b>													
<b>71M2-8</b>	0.12	0.45	0.36	700	62.5	0.61	1.64	2.2	3.5	2.7	0.0025	25	41	53
<b>80M1-8</b>	0.18	0.71	0.57	705	63	0.58	2.43	1.9	3.2	2.7	0.0033	31	42	54
<b>80M2-8</b>	0.25	0.90	0.72	710	67	0.60	3.35	1.7	3.3	2.5	0.0046	35	42	54
<b>90S-8</b>	0.37	1.16	0.93	715	72	0.64	4.95	1.7	4.4	3	0.008	44	46	58
<b>90L-8</b>	0.55	1.68	1.34	715	74	0.64	7.3	1.8	4.5	3.1	0.0095	46	46	58
<b>100L1-8</b>	0.75	2.25	1.80	720	76	0.64	9.9	2.3	5	2.9	0.008	44	49	61
<b>100L2-8</b>	1.1	3.1	2.5	715	78	0.67	14.7	2.2	4.8	2.7	0.0095	46	49	61
<b>112M-8</b>	1.5	3.5	2.8	705	80.6	0.77	20.3	2	4.9	2.6	0.017	59	52	64
<b>132S-8</b>	2.2	5.4	4.3	710	82	0.72	29.6	2.8	6.3	3.2	0.029	97	53	66
<b>132M-8</b>	3	7.2	5.8	715	83.5	0.72	40	2.7	6.3	3.1	0.036	113	53	66
<b>160M1-8</b>	4	8.8	7	725	85.5	0.77	53	1.9	5.6	2.6	0.071	157	54	67
<b>160M2-8</b>	5.5	12	9.7	725	86.5	0.76	72	2.3	6	3.1	0.105	170	54	67
<b>160L-8</b>	7.5	16.6	13.3	725	87.9	0.74	99	2.4	6.5	3.2	0.136	190	54	67
<b>180L-8</b>	11	23	18.3	725	89.2	0.78	145	2.6	6.9	3.3	0.22	215	56	69
<b>200L-8</b>	15	31	25	730	90.3	0.77	196	2.4	7.1	3.3	0.4	280	56	70
<b>225S-8</b>	18.5	37.5	30	735	90.7	0.78	240	2.3	7.1	3.4	0.56	372	57	71
<b>225M-8</b>	22	44.5	35.5	735	91.2	0.78	286	2.4	7.2	3.5	0.69	404	57	71
<b>250M-8</b>	30	59	47	735	92.5	0.8	390	2.5	7.1	3.4	1.2	550	58	72
<b>280S-8</b>	37	70	56	735	92.7	0.82	481	2	6.5	2.9	1.9	740	61	75
<b>280M-8</b>	45	85	68	740	92.9	0.82	581	2.2	6.7	2.9	2.3	800	61	75
<b>315S-8</b>	55	103	82	740	93.2	0.83	710	2.7	6	2.5	4.3	995	68	83
<b>315M-8</b>	75	139	111	740	93.6	0.83	968	2.8	6.3	2.6	5	1050	68	83
<b>315L1-8</b>	90	166	133	740	94.1	0.83	1161	2.9	6.6	2.7	6	1145	68	83
<b>315L2-8</b>	110	205	164	740	94.5	0.82	1420	2.9	6.8	2.7	7.3	1265	68	83
<b>315L3-8</b>	132	245	196	740	94.6	0.82	1704	2.8	6.3	2.6	8.3	1440	68	83
<b>355M-8</b>	160	290	235	745	95.4	0.83	2051	1.7	6.4	2.6	11.4	1750	70	86
<b>355L1-8</b>	200	370	295	745	95.6	0.82	2564	1.6	6.6	2.6	13.9	1950	70	86
<b>355L2-8</b>	250	460 <sup>1)</sup>	370	745	95.6	0.82	3205	1.4	6.1	2.6	17.7	2300	70	86
<b>400M-8</b>	315	570 <sup>1)</sup>	455 <sup>1)</sup>	745	96.2	0.83	4038	1.2	6.2	2.7	30	3100	73	89
<b>400L-8</b>	355	640 <sup>1)</sup>	515 <sup>1)</sup>	745	96.3	0.83	4551	1	6.1	2.6	34	3440	73	89
<b>450M-8</b>	400	710 <sup>1)</sup>	570 <sup>1)</sup>	745	96.6	0.84	5128	1	6.1	2.8	51	3750	74	90
<b>450L-8</b>	450	800 <sup>1)</sup>	640 <sup>1)</sup>	745	96.7	0.84	5768	1	6.1	2.8	57	4050	74	90
<b>500..</b>	by request													

**Note:**

- 1) Two parallel supply lines are required
- 2) Type B3 with terminal compartment type EAR

The values are also valid for series BD..

# IE3

## Mains operation 60 Hz

Temperature class T4,  
ns = 3600 rpm, 2p = 2

66

Size	Output		Rated current at		Speed n [rpm]	Efficiency $\eta$ [%]	Power factor cos $\varphi$	Torque M [Nm]	Starting torque M <sub>A</sub> / M <sub>N</sub>	Starting current I <sub>A</sub> / I <sub>N</sub>	Break down torque M <sub>K</sub> / M <sub>N</sub>	Mass-moment of inertia J [kgm <sup>2</sup> ]	Weight <sup>2)</sup> m [kg]	Noise values with radial fan	
	P <sub>2</sub> [kW]	I [A]	400 V I [A]	500 V I [A]										L <sub>P</sub> [dB(A)]	L <sub>W</sub> [dB(A)]
<b>CD...Y3</b>	<b>IE3 Efficiency according to IEC 60034-30</b>														
<b>63M1-2</b>	0.18	0.4	0.26	3465	71.5	0.79	0.5	3.7	7	5.5	0.00028	16	53	65	
<b>63M2-2</b>	0.25	0.52	0.35	3455	74	0.81	0.69	3.6	6.7	5.3	0.00028	16	53	65	
<b>71M1-2</b>	0.37	0.73	0.49	3440	75.5	0.84	1.03	3	6.7	3.9	0.00058	24	56	68	
<b>71M2-2</b>	0.55	1.03	0.67	3445	79.5	0.84	1.52	3.1	7.1	4.2	0.00080	25	56	68	
<b>80M1-2</b>	0.75	1.4	0.94	3490	79.9	0.84	2.11	3.3	7.7	4.2	0.0013	31	60	72	
<b>80M2-2</b>	1.1	1.93	1.31	3490	84	0.85	3.64	3.5	7.9	4.3	0.0018	35	60	72	
<b>90S-2</b>	1.5	2.55	1.71	3505	85.6	0.87	4.1	3.4	8.5	3.8	0.0029	45	65	77	
<b>90L-2</b>	2.2	3.6	2.45	3505	87	0.88	6	3.4	8.5	3.9	0.0039	48	65	77	
<b>100L-2</b>	3	4.85	3.35	3520	89.5	0.87	8.1	2.9	8.2	3.4	0.0051	53	68	80	
<b>112M-2</b>	4	6.4	4.4	3530	89.5	0.87	10.8	3.2	8.3	4	0.0089	95	68	80	
<b>132S1-2</b>	5.5	8.7	5.9	3520	89.5	0.89	14.9	2.9	8.3	3.7	0.0125	103	68	81	
<b>132S2-2</b>	7.5	11.7	7.9	3525	90.5	0.89	20.3	3.1	8.4	4	0.0177	115	68	81	
<b>160M1-2</b>	11	18.1	12.1	3540	91	0.84	29.7	3.3	8.5	4	0.032	163	71	84	
<b>160M2-2</b>	15	23	15.6	3545	91.5	0.89	40.5	3.6	8.5	4	0.043	173	71	84	
<b>160L-2</b>	18.5	27.5	18.6	3545	92	0.91	49.8	3.3	8.4	3.9	0.052	188	71	84	
<b>180M-2</b>	22	34	23	3560	92.2	0.88	59	3.2	8.6	3.8	0.075	196	75	88	
<b>200L1-2</b>	30	45	30.5	3555	92.5	0.9	81	3.1	8.4	3.6	0.13	254	77	91	
<b>200L2-2</b>	37	55	37	3560	93	0.9	99	3.3	8.6	3.8	0.16	278	77	91	
<b>225M-2</b>	45	68	45	3555	93.6	0.89	121	3	8.4	3.3	0.24	400	78	92	
<b>250M-2</b>	55	85	57	3575	93.6	0.87	147	3	8.3	3.3	0.4	545	81	95	
<b>280S-2</b>	75	115	77	3570	94.1	0.87	201	2.7	8.2	3.1	0.65	700	82	96	
<b>280M-2</b>	90	137	92	3570	95.1	0.87	241	3.1	8.4	3.4	0.78	762	82	96	
<b>315S-2</b>	110	163	109	3575	95.1	0.89	294	2.7	8.2	3.1	1.4	960	82	96	
<b>315M-2</b>	132	193	129	3575	95.4	0.9	353	2.9	8.5	3.2	1.6	1025	82	96	
<b>315L1-2</b>	160	235	156	3580	95.4	0.9	427	2.8	8.6	3	1.7	1065	82	96	
<b>315L2-2</b>	200	290	195	3580	95.8	0.9	533	2.6	8	3	2.2	1270	82	96	
<b>315L3-2</b>	250	360	240	3580	95.8	0.91	667	2	8.4	3.1	2.8	1420	82	96	
<b>355L1-2</b>	345	490 <sup>1)</sup>	325	3575	96.1	0.92	922	1.6	7.1	3	4.5	1900	87	103	
<b>355L2-2</b>	390	545 <sup>1)</sup>	365	3580	96.3	0.93	1040	1.5	7.3	2.8	5	2050	87	103	
<b>355L3-2</b>	440	615 <sup>1)</sup>	410 <sup>1)</sup>	3580	96.3	0.93	1174	1.4	7.4	2.8	5.5	2350	87	103	
<b>400L-2</b>	495	685 <sup>1)</sup>	455 <sup>1)</sup>	3585	96.5	0.94	1319	1.15	7.6	3	8.5	2910	87	103	

**Note:**

- 1) Two parallel supply lines are required
- 2) Type B3 with terminal compartment type EAR

The values are also valid for series BD..

# IE3 Mains operation 60 Hz

Temperature class T4,  
ns = 1800 rpm, 2p = 4

67

Size	Output P <sub>2</sub> [kW]	Rated current at		Speed n [rpm]	Efficiency η [%]	Power factor cos φ	Torque M [Nm]	Starting torque M <sub>A</sub> / M <sub>N</sub>	Starting current I <sub>A</sub> / I <sub>N</sub>	Breakdown torque M <sub>k</sub> / M <sub>N</sub>	Mass-moment of inertia J [kgm <sup>2</sup> ]	Weight <sup>2)</sup> m [kg]	Noise values with radial fan		Noise values with axial fan		
		400 V I [A]	500 V I [A]										L <sub>P</sub> [dB(A)]	L <sub>W</sub> [dB(A)]	L <sub>P</sub> [dB(A)]	L <sub>W</sub> [dB(A)]	
<b>CD...Y3</b>					<b>IE3 Efficiency according to IEC 60034-30</b>												
63M1-4	0.12	0.33	0.22	1745	69.5	0.66	0.66	3.9	6.1	4.3	0.00046	16	48	60	-	-	
63M2-4	0.18	0.44	0.29	1735	74	0.69	0.99	3.3	6.1	3.9	0.00063	17	48	60	-	-	
71M1-4	0.25	0.62	0.41	1750	74.5	0.68	1.36	3.6	6.6	4.3	0.00092	24	49	61	-	-	
71M2-4	0.37	0.86	0.57	1745	78.5	0.69	2	4.2	7.3	4.5	0.0013	25	49	61	-	-	
80M1-4	0.55	1.08	0.72	1755	82	0.78	3	3.4	7.9	4.1	0.0021	31	50	62	-	-	
80M2-4	0.75	1.48	0.99	1750	83.5	0.77	4.1	3.7	7.8	4.8	0.0029	35	50	62	-	-	
90S-4	1.1	2.05	1.37	1760	86.5	0.78	6	3	8.2	3.7	0.0056	44	53	65	-	-	
90L-4	1.5	2.8	1.88	1760	86.5	0.79	8.1	3	8.3	3.8	0.0056	46	53	65	-	-	
100L1-4	2.2	3.85	2.55	1775	89.5	0.79	11.8	2.9	8.9	4.5	0.011	59	57	69	-	-	
100L2-4	3	5.4	3.6	1770	89.5	0.83	16.2	2.3	8.4	4	0.011	59	57	69	-	-	
112M-4	4	7.1	4.8	1765	89.5	0.8	21.6	3.6	8.6	4.1	0.022	100	59	71	-	-	
132S-4	5.5	9.5	6.3	1775	91.5	0.82	29.6	4.2	8.9	4.5	0.041	113	62	75	59	72	
132M-4	7.5	12.4	8.3	1775	91.5	0.81	40.4	4.3	8.9	4.6	0.041	125	62	75	59	72	
160M-4	11	17.8	11.9	1770	92.4	0.85	59	3.8	8.4	4	0.079	184	67	80	60	73	
160L-4	15	24.5	16.3	1770	93	0.84	81	3.4	8.5	3.6	0.083	208	67	80	60	73	
180M-4	18.5	32	21	1772	93.6	0.83	100	3.6	8.9	3.6	0.164	217	65	78	61	74	
180L-4	22	35.5	23.5	1770	93.6	0.84	119	3.8	9	3.8	0.164	244	65	78	61	74	
200L-4	30	50	33	1770	94.1	0.82	162	3.5	8.5	3.8	0.25	274	66	80	62	76	
225S-4	37	59	39	1780	94.5	0.87	199	3.5	8.1	3.3	0.48	372	68	82	64	78	
225M-4	45	70	47	1781	95	0.85	241	3.8	8.4	3.6	0.48	402	68	82	64	78	
250M-4	55	84	56	1787	95.4	0.84	294	2.7	8.3	3.5	0.75	588	70	84	68	82	
280S-4	75	120	80	1780	95.4	0.83	402	3.7	8.1	3.5	1.48	740	74	88	71	85	
280M-4	90	140	93	1787	95.4	0.85	481	3.7	8.1	3.5	1.48	820	74	88	71	85	
315S-4	110	173	115	1785	95.8	0.84	589	3	8	2.8	2.2	1040	76	91	72	87	
315M-4	132	205	138	1786	96.2	0.84	706	3	8.1	2.8	2.7	1120	76	91	72	87	
315L1-4	160	250	165	1786	96.2	0.85	856	3.4	8.2	3.2	3.1	1210	76	91	72	87	
315L2-4	200	310	210	1788	96.2	0.84	1068	3.2	7.7	3	3.9	1430	76	91	72	87	
315L3-4	250	370	250	1792	96.3	0.88	1337	2	8.5	3.1	4.6	1565	76	91	72	87	
355L1-4	345	505 <sup>1)</sup>	335	1790	96.3	0.89	1841	1.6	7.3	2.8	6.1	2050	78	94	74	90	
355L2-4	390	570 <sup>1)</sup>	380	1790	96.6	0.89	2081	1.7	7.3	3	6.7	2200	78	94	74	90	
355L3-4	440	635 <sup>1)</sup>	420 <sup>1)</sup>	1790	97	0.9	2347	1.6	7.4	3	7.4	2430	78	94	74	90	
400M-4	495	705 <sup>1)</sup>	470 <sup>1)</sup>	1794	97	0.91	2635	1.15	7.7	2.8	18.0	2850	84	100	-	-	
400L-4	550	780 <sup>1)</sup>	520 <sup>1)</sup>	1794	97.1	0.91	2928	1.15	7.7	2.8	20.0	3230	84	100	-	-	
450M-4	610	865 <sup>1)</sup>	575 <sup>1)</sup>	1794	97.2	0.91	3247	1.05	7.2	2.8	26.0	3500	85	101	-	-	
450L-4	690	975 <sup>1)</sup>	650 <sup>1)</sup>	1794	97.4	0.91	3673	1.05	7.2	2.8	31.0	3800	85	101	-	-	

**Note:**

- 1) Two parallel supply lines are required
- 2) Type B3 with terminal compartment type EAR

The values are also valid for series BD..

# IE3 Mains operation 60 Hz

Temperature class T4  
ns = 1200 rpm, 2p = 6

68

Size	Output P <sub>2</sub> [kW]	Rated current at		Speed n [rpm]	Efficiency η [%]	Power factor cos φ	Torque M [Nm]	Starting torque M <sub>A</sub> / M <sub>N</sub>	Starting current I <sub>A</sub> / I <sub>N</sub>	Breakdown torque M <sub>K</sub> / M <sub>N</sub>	Mass moment of inertia J [kgm <sup>2</sup> ]	Weight <sup>2)</sup> m [kg]	Noise values with radial fan		
		400 V I [A]	500 V I [A]										L <sub>P</sub> [dB(A)]	L <sub>W</sub> [dB(A)]	
CD...Y3					IE3	Efficiency according to IEC 60034-30									
71M2-6	0.25	0.67	0.45	1147	69	0.68	2.1	2.9	5.1	3.7	0.00250	25	48	60	
80M1-6	0.37	0.96	0.64	1158	75.5	0.64	3.05	2.5	4.9	3.2	0.00330	31	48	60	
80M2-6	0.55	1.33	0.88	1153	76.5	0.68	4.6	2.1	5.3	3.6	0.00460	35	48	60	
90S-6	0.75	1.76	1.17	1165	82.5	0.65	6.1	3.2	6.4	3.6	0.00800	44	51	63	
90L-6	1.1	2.3	1.52	1170	87.5	0.69	9	3	7.1	4.1	0.017	59	54	66	
100L-6	1.5	3.2	2.1	1170	88.5	0.67	12.2	3.5	7.8	4.4	0.017	59	54	66	
112M-6	2.2	4.15	2.8	1170	89.5	0.74	19	3	7.9	3.6	0.031	100	58	70	
132S-6	3	5.8	3.9	1170	89.5	0.72	24.5	3.7	8.2	4.3	0.031	100	61	74	
132M1-6	4	7.5	5	1170	89.5	0.75	32.6	3.4	7.9	4.3	0.037	104	61	74	
132M2-6	5.5	10.5	7	1174	91	0.72	44.7	3.6	8.3	4.7	0.057	127	61	74	
160M-6	7.5	13.1	8.7	1177	91	0.79	61	3.1	8.6	4.5	0.12	190	63	76	
160L-6	11	19.3	12.9	1177	91.7	0.78	89	3.2	8.8	4.6	0.14	220	63	76	
180L-6	15	26	17.3	1179	91.7	0.79	122	3.1	8.8	4.7	0.19	215	63	76	
200L1-6	18.5	31	21	1182	93	0.8	149	3	8.8	4.2	0.28	270	63	77	
200L2-6	22	37	24.5	1181	93	0.8	178	3	8.8	4.2	0.31	280	63	77	
225M-6	30	52	34.5	1190	94.4	0.77	241	2.3	7.8	2.9		404	67	81	
250M-6	37	by request			94.1					by request					
280S-6	45	by request			94.5					by request					
280M-6	55	92	62	1187	94.5	0.79	443	3.3	7.6	2.8	1.7	770	70	84	
315S-6	75	115	77	1190	95	0.86	602	3.6	8.7	3.3	4.3	995	75	90	
315M-6	90	135	90	1190	95	0.88	722	3.6	8.6	3.3	5	1050	75	90	
315L1-6	110			1190							6				
315L2-6	132	199	133	1190	95.8	0.87	1059	3.5	8.5	3.3	7.3	1265	75	90	
315L3-6	160	240	159	1190	95.8	0.88	1284	3.6	8.7	3.3	8.3	1440	75	90	
355M-6	220	330	220	1190	95.8	0.88	1766	1.9	7.1	2.8	11.3	1750	80	96	
355L1-6	275	410	275	1190	95.9	0.88	2207	1.9	7.1	2.8	13.8	1950	80	96	
355L2-6	345	515	340	1190	96	0.88	2769	1.05	6.9	2.7	23	2650	80	96	
400M-6	390	570	380	1193	96.6	0.89	3122	1.15	7	2.8	27	2850	84	100	
400L-6	440	640	430	1193	96.6	0.89	3522	1.15	7.2	2.7	31	3230	84	100	
450M-6	495	725	480	1194	96.6	0.89	3959	1.3	7.2	3	46	3500	84	100	
450L-6	550	800	535	1194	97	0.89	4399	1.15	7.2	2.8	51	3800	84	100	

#### Note:

- 1) Two parallel supply lines are required
- 2) Type B3 with terminal compartment type EAR

The values are also valid for series BD..

# IE3 Mains operation 60 Hz

Temperature class T4  
ns = 900 rpm, 2p = 8

69

Size	Output P <sub>2</sub> [kW]	Rated current at		Speed n [rpm]	Efficiency η [%]	Power factor cos φ	Torque M [Nm]	Starting torque M <sub>A</sub> / M <sub>N</sub>	Starting current I <sub>A</sub> / I <sub>N</sub>	Break down torque M <sub>K</sub> / M <sub>N</sub>	Mass moment of inertia J [kgm <sup>2</sup> ]	Weight <sup>2)</sup> m [kg]	Noise values with radial fan		
		400 V I [A]	500 V I [A]										L <sub>P</sub> [dB(A)]	L <sub>W</sub> [dB(A)]	
<b>CD...Y3</b>	<b>IE3 Efficiency according to IEC 60034-30</b>														
71M2-8	0.12							by request							
80M1-8	0.18							by request							
80M2-8	0.25							by request							
90S-8	0.37							by request							
90L-8	0.55							by request							
100L1-8	0.75							by request							
100L2-8	1.1							by request							
112M-8	1.5							by request							
132S-8	2.2	4.6	3.1	869	85.5	0.7	24	2.9	5.9	3.5	0.029	97			
132M-8	3							by request							
160M1-8	4							by request							
160M2-8	5.5	11.1	7.4	879	86.5	0.72	60	2.6	6.2	3.3	0.105	170	60	73	
160L-8	7.5							by request							
180L-8	11							by request							
200L-8	15							by request							
225S-8	18.5							by request							
225M-8	22							by request							
250M-8	30							by request							
280S-8	37							by request							
280M-8	45	76	51	888	92.4	0.8	483.6	2.44	8	3.88	2.3	800			
315S-8	55	98	65	890	94.2	0.75	588	3.88	7.91	3.79	4.3	995	68	83	
315M-8	75							by request							
315L1-8	90							by request							
315L2-8	110							by request							
315L3-8	132							by request							
355M-8	176	280	187	890	95.1	0.83	1889	2	6.5	2.5	11.4	1750	76	92	
355L1-8	220	350	230	895	95.5	0.83	2347	1.8	7	2.5	13.9	1950	76	92	
355L2-8	275	440	295	895	95.6	0.82	2934	1.8	7	2.5	17.7	2300	76	92	
400M-8	345	535	355	895	96.2	0.84	3681	1.3	6.5	2.5	30	3100	79	95	
400L-8	390	610	410	895	96.3	0.83	4161	1.05	6.4	2.3	34	3440	80	96	
450M-8	440	680	455	895	96.6	0.84	4695	1.05	6.4	2.3	51.0	3750	80	96	
450L-8	495	765	510	895	96.7	0.84	5282	1.05	6.4	2.3	57.0	4050	80	96	

**Note:**

- 1) Two parallel supply lines are required
- 2) Type B3 with terminal compartment type EAR

The values are also valid for series BD..

# IE1

## Mains operation 50 Hz

Temperature class T4,  
ns = 3000 rpm, 2p = 2

70

Size	Output P <sub>2</sub> [kW]	Rated current at		Speed n [rpm]	Efficiency η [%]	Power factor cos φ	Torque M [Nm]	Starting torque M <sub>A</sub> / M <sub>N</sub>	Starting current I <sub>A</sub> / I <sub>N</sub>	Break down torque M <sub>K</sub> / M <sub>N</sub>	Mass moment of inertia J [kgm <sup>2</sup> ]	Weight <sup>2)</sup> m [kg]	Noise values with radial fan		Noise values with axial fan	
		400 V I [A]	500 V I [A]										L <sub>P</sub> [dB(A)]	L <sub>W</sub> [dB(A)]	L <sub>P</sub> [dB(A)]	L <sub>W</sub> [dB(A)]
<b>CD..</b>					<b>IE1</b>		<b>Efficiency according to IEC 60034-30</b>									
63M1-2	0.18	0.59	0.47	2905	66	0.67	0.59	4.6	6.8	6.5	0.00028	16	49	61	-	-
63M2-2	0.25	0.69	0.55	2860	70	0.75	0.83	3.4	5.8	4.7	0.00028	16	49	61	-	-
71M1-2	0.37	0.89	0.71	2800	71.5	0.84	1.26	2.7	5.2	3.5	0.00028	16	51	63	-	-
71M2-2	0.55	1.34	1.08	2810	72	0.82	1.87	2.8	5.5	3.6	0.00039	17	51	63	-	-
80M1-2	0.75	1.73	1.38	2790	74.5	0.84	2.57	2.7	4.8	3.3	0.00058	24	55	67	-	-
80M2-2	1.1	2.5	1.99	2820	78	0.82	3.73	2.8	5.5	3.5	0.0008	25	55	67	-	-
90S-2	1.5	3.25	2.6	2840	77.8	0.86	5	2.9	5.9	3.2	0.0013	31	60	72	-	-
90L-2	2.2	4.55	3.65	2850	82	0.85	7.4	3	6.3	3.5	0.0018	35	60	72	-	-
100L-2	3	6.1	4.85	2850	82	0.87	10.1	2.7	6.8	3.3	0.0029	45	63	75	-	-
112M-2	4	7.7	6.2	2880	85	0.88	13.3	2.3	6.5	3.1	0.0051	53	63	75	55	67
132S1-2	5.5	10.7	8.5	2880	85.5	0.87	18.2	2.5	6.4	3.3	0.0089	95	63	76	55	68
132S2-2	7.5	14.4	11.5	2910	86.5	0.87	24.6	2.7	6.8	3.5	0.0125	100	63	76	55	68
160M1-2	11	20	16	2925	89	0.89	36	2.8	6.6	3.2	0.032	163	66	79	56	69
160M2-2	15	26.5	21.5	2920	89	0.91	49	2.8	6.8	3.2	0.043	173	66	79	56	69
160L-2	18.5	32	25.5	2925	90.5	0.92	60	2.6	6.8	3.1	0.052	188	66	79	56	69
180M-2	22	38	30.5	2925	91.2	0.92	72	2.5	6.9	3	0.075	196	69	82	58	71
200L1-2	30	52	42	2955	92	0.90	97	2.6	7.2	2.9	0.13	254	71	85	60	74
200L2-2	37	79	51	2955	92.5	0.91	120	2.7	7.2	3	0.16	278	71	85	60	74
225M-2	45	79	63	2960	92.8	0.89	145	2.5	7.1	3	0.24	400	72	86	60	74
250M-2	55	96	77	2970	93.2	0.89	177	2.4	7.1	2.8	0.4	545	75	89	64	78
280S-2	75	130	104	2970	93.6	0.89	241	2.2	6.8	2.7	0.65	700	76	90	66	80
280M-2	90	154	123	2970	93.8	0.90	289	2.4	6.8	2.8	0.78	762	76	90	66	80
315S-2	110	190	152	2975	94	0.89	353	2	6.5	2.4	1.4	960	76	91	66	81
315M-2	132	225	182	2975	94.3	0.89	424	2.1	6.8	2.5	1.6	1025	76	91	66	81
315L1-2	160	270	215	2975	94.5	0.90	514	2.4	6.9	2.7	1.9	1065	76	91	66	81
315L2-2	200	340	270	2980	94.7	0.90	641	2.3	6.9	2.6	2.2	1270	76	91	66	81
315L3-2	250	410 <sup>1)</sup>	325	2980	96	0.92	801	1.7	7.2	2.7	2.8	1420	76	91	66	81
355L1-2	315	510 <sup>1)</sup>	410 <sup>1)</sup>	2980	96.6	0.92	1009	1.5	6.7	2.8	4.5	1900	81	97	68	84
355L2-2	355	570 <sup>1)</sup>	455 <sup>1)</sup>	2985	96.8	0.93	1136	1.4	6.9	2.7	5	2050	81	97	68	84
355L3-2	400	640 <sup>1)</sup>	515 <sup>1)</sup>	2985	96.8	0.93	1280	1.3	7	2.8	5.5	2350	81	97	68	84
400L-2	450	710 <sup>1)</sup>	570 <sup>1)</sup>	2990	97	0.94	1437	1.1	7.2	2.8	8.5	2910	81	97	-	-

**Note:**

- 1) Two parallel supply lines are required
- 2) Type B3 with terminal compartment type EAR

The values are also valid for series BD..

# Inverter operation 50 Hz

Temperature class T4,  
ns = 3000 rpm, 2p = 2

71

40 °C ambient temperature. winding heating within heat class F

Operation on	Mains	Inverter										Inverter	
Ventilation		Self-ventilation										Forced ventilation	
Torque trend	-	square decreasing	constant	constant	constant	constant	constant	constant	constant	constant	constant	constant	constant
Frequency	50 Hz	5-50 Hz		20-50 Hz		10-50 Hz		5-50 Hz		50-87 Hz <sup>1)</sup>		5-87 Hz <sup>1)</sup>	
Control range	-	1:10		1:2.5		1:5		1:10		3000-5220 rpm		300-5220 rpm	
Speed range	-	300-3000 rpm		1200-3000 rpm		600-3000 rpm		300-3000 rpm		3000-5220 rpm		300-5220 rpm	
Power/torque CD..	P <sub>2</sub> [kW]	P <sub>U</sub> [kW]	M <sub>U</sub> [Nm]	P <sub>U</sub> [kW]	M <sub>U</sub> [Nm]	P <sub>U</sub> [kW]	M <sub>U</sub> [Nm]	P <sub>U</sub> [kW]	M <sub>U</sub> [Nm]	P <sub>U</sub> [kW]	M <sub>U</sub> [Nm]	P <sub>U</sub> [kW]	P <sub>U</sub> [kW]
		50 Hz		50 Hz		50 Hz		50 Hz		87 Hz		50 Hz 87 Hz	
63M1-2	0.18	0.18	0.59	0.16	0.52	0.14	0.46	0.12	0.39	0.25	0.47	-	-
63M2-2	0.25	0.25	0.83	0.22	0.73	0.19	0.63	0.15	0.49	0.37	0.7	-	-
71M1-2	0.37	0.37	1.25	0.35	1.2	0.3	1	0.22	0.74	0.55	1	-	-
71M2-2	0.55	0.55	1.9	0.52	1.8	0.45	1.5	0.33	1.1	0.8	1.5	-	-
80M1-2	0.75	0.75	2.57	0.7	2.4	0.6	2	0.5	1.7	1.1	2	-	-
80M2-2	1.1	1.1	3.73	1	3.4	0.9	3	0.75	2.5	1.6	2.9	-	-
90S-2	1.5	1.5	5	1.4	4.7	1.2	4	1	3.3	2.2	4	-	-
90L-2	2.2	2.2	7.4	2	6.7	1.7	5.7	1.4	4.7	3.3	6	-	-
100L-2	3	3	10.1	2.7	8.9	2.2	7.2	1.8	5.9	4.5	8.2	-	-
112M-2	4	4	13.3	3.7	12	3.2	11	2.5	8.2	6	11	-	-
132S1-2	5.5	5.5	18.2	5	16	4.5	15	3.7	12	8	15	5.5	8
132S2-2	7.5	7.5	24.6	7	23	6	20	5	16	11	20	7.5	10.5
160M1-2	11	11	36	10	32	9	29	7.5	24	16	29	11	15
160M2-2	15	14.5 <sup>2)</sup>	47	13	42	12	39	10	32	21	38	14.5	20
160L-2	18.5	17.5 <sup>2)</sup>	57	16	52	15	49	12.5	41	26	48	17.5	25
180M-2	22	21 <sup>2)</sup>	68	20	65	18	58	15	49	30	55	21	29
200L1-2	30	28 <sup>2)</sup>	90	27	87	24	77	22	71	40	73	28	38
200L2-2	37	32 <sup>2)</sup>	103	31	100	28	90	27	87	49	90	32	45
225M-2	45	38 <sup>2)</sup>	123	37	119	34	110	32	103	60	110	38	55

Frequency											50-60 Hz <sup>1)</sup>		5-60 Hz <sup>1)</sup>	
Speed range											3000-3600 rpm		300-3600 rpm	
250M-2	55	47 <sup>2)</sup>	151	45	145	43	138	41	132	47	126	47	47	
280S-2	75	62 <sup>2)</sup>	199	60	193	58	186	55	177	62	166	62	62	
280M-2	90	75 <sup>2)</sup>	241	73	234	70	225	67	215	75	201	75	75	
315S-2	110	95 <sup>2)</sup>	304	90	288	88	282	85	272	95	258	95	95	
315M-2	132	115	369	110	353	105	336	100	320	115	307	115	115	
315L1-2	160	140	449	135	433	128	410	120	385	140	374	140	140	
315L2-2	200	175	560	165	528	160	512	150	480	175	467	175	175	
315L3-2	250	215	688	205	656	200	640	185	592	215	574	215	215	
355L1-2	315	270	865	260	832	250	800	235	752	270	813	270	270	
355L2-2	355	305	976	295	944	285	912	265	848	305	918	305	305	
355L3-2	400	345	1104	335	1072	320	1024	300	960	345	1038	345	345	
400L-2	450	390	1245	375	1197	360	1149	340	1085	390	201	390	-	

## Notes

<sup>1)</sup> Higher frequencies by request.

<sup>2)</sup> For inverter operation with output filter and practically sinusoidal output voltage. or clock frequency  $\geq 4$  kHz. output like P<sub>2</sub>.

Output during operation at the inverter (guide values). torque curves page 58

Overload protection via temperature sensor

ATTENTION: From 01.07.2021, motors with efficiency classes IE1 and IE2 may only be supplied to the EU area as replacement motors for identical ATB motors that are already in operation.

# IE1

## Mains operation 50 Hz

Temperature class T4,  
ns = 1500 rpm, 2p = 4

72

Size	Output	Rated current at		Speed	Efficiency	Power factor	Torque	Starting torque	Starting current	Break down torque	Mass moment of inertia	Weight <sup>2)</sup>	Noise values with radial fan		Noise values with axial fan	
		400 V	500 V										L <sub>P</sub>	L <sub>W</sub>	L <sub>P</sub>	L <sub>W</sub>
CD..	P <sub>2</sub> [kW]	I [A]	I [A]	n [rpm]	η [%]	cos φ	M [Nm]	M <sub>A</sub> /M <sub>N</sub>	I <sub>A</sub> /I <sub>N</sub>	M <sub>K</sub> /M <sub>N</sub>	J [kgm <sup>2</sup> ]	m [kg]	L <sub>P</sub> [dB(A)]	L <sub>W</sub> [dB(A)]	L <sub>P</sub> [dB(A)]	L <sub>W</sub> [dB(A)]
					<b>IE1</b>	<b>Efficiency according to IEC 60034-30</b>										
63M1-4	0.12	0.43	0.34	1445	67	0.60	0.79	3.9	5.6	3.9	0.00046	16	44	56	-	-
63M2-4	0.18	0.53	0.42	1415	70	0.70	1.21	2.7	4.7	2.7	0.00046	16	44	56	-	-
71M1-4	0.25	0.66	0.53	1370	68.5	0.80	1.74	2	3.9	2.3	0.00046	16	45	57	-	-
71M2-4	0.37	0.94	0.75	1380	71	0.80	2.56	2.2	3.9	2.3	0.00063	17	45	57	-	-
80M1-4	0.55	1.38	1.10	1380	72	0.80	3.8	2	3.8	2.3	0.00092	24	46	58	-	-
80M2-4	0.75	1.81	1.45	1400	75.5	0.79	5.1	2.1	4.5	2.5	0.0013	25	46	58	-	-
90S-4	1.1	2.55	2.05	1400	76	0.83	7.5	2.1	4.8	2.5	0.0021	31	49	61	-	-
90L-4	1.5	3.35	2.65	1405	79	0.82	10.2	2.3	5	2.7	0.0029	35	49	61	-	-
100L1-4	2.2	4.95	3.95	1420	80	0.80	14.8	2.4	5.4	2.8	0.0046	44	52	64	-	-
100L2-4	3	6.5	5.2	1415	81.7	0.82	20.2	2.3	5.5	2.7	0.0056	46	52	64	-	-
112M-4	4	8.1	6.5	1435	85	0.84	26.6	2.7	6.8	3.2	0.0110	59	54	66	-	-
132S-4	5.5	10.8	8.6	1440	86.5	0.85	36.5	2.5	6.4	2.7	0.0220	100	57	70	55	68
132M-4	7.5	14.3	11.4	1440	88	0.86	50	2.7	6.5	2.8	0.030	110	57	70	55	68
160M-4	11	21	16.7	1460	89.5	0.85	72	2.5	6.6	2.8	0.057	168	62	75	56	69
160L-4	15	28	22.5	1455	90	0.86	98	2.8	6.7	3.1	0.079	184	62	75	56	69
180M-4	18.5	35	28	1460	91	0.84	121	2.9	6.7	3	0.13	198	60	73	57	70
180L-4	22	41.5	33	1460	91.5	0.84	144	3	6.9	3	0.155	217	60	73	57	70
200L-4	30	53	42.5	1460	92.2	0.88	196	2.6	6.8	2.9	0.25	274	61	75	58	72
225S-4	37	66	52	1465	92.6	0.88	241	2.7	6.7	2.6	0.4	372	63	77	59	73
225M-4	45	80	64	1470	92.8	0.88	292	2.7	6.5	2.6	0.48	402	63	77	59	73
250M-4	55	96	77	1470	93.2	0.89	357	2.9	7.1	2.9	0.75	573	65	79	64	78
280S-4	75	134	107	1480	93.8	0.86	484	2.6	6.8	2.5	1.25	740	68	82	66	80
280M-4	90	161	129	1480	94	0.86	581	2.8	6.9	2.6	1.48	820	68	82	66	80
315S-4	110	198	159	1485	94.2	0.85	707	2.5	6.7	2.5	2.2	1040	69	84	66	81
315M-4	132	235	190	1485	94.4	0.85	849	2.6	6.8	2.6	2.7	1120	69	84	66	81
315L1-4	160	285	225	1485	94.7	0.86	1029	2.7	6.9	2.6	3.1	1210	69	84	66	81
315L2-4	200	355	285	1485	94.9	0.86	1286	2.7	6.9	2.6	3.9	1430	69	84	66	81
315L3-4	250	430 <sup>1)</sup>	345	1490	96.2	0.87	1602	1.7	7.3	2.7	4.6	1565	69	84	66	81
355L1-4	315	525 <sup>1)</sup>	420 <sup>1)</sup>	1490	96.3	0.90	2019	1.5	6.9	2.7	6.1	2050	72	88	68	84
355L2-4	355	590 <sup>1)</sup>	470 <sup>1)</sup>	1490	96.6	0.90	2275	1.6	6.9	2.8	6.7	2200	72	88	68	84
355L3-4	400	665 <sup>1)</sup>	530 <sup>1)</sup>	1490	97	0.90	2564	1.5	7	2.8	7.4	2430	72	88	68	84
400M-4	450	735 <sup>1)</sup>	590 <sup>1)</sup>	1495	97	0.91	2875	1.1	7.3	2.7	18	2850	78	94	-	-
400L-4	500	815 <sup>1)</sup>	655 <sup>1)</sup>	1495	97.1	0.91	3194	1.1	7.3	2.7	20	3230	78	94	-	-
450M-4	560	915 <sup>1)</sup>	730 <sup>1)</sup>	1495	97.2	0.91	3577	1	6.8	2.7	26	3500	79	95	-	-
450L-4	630	1025 <sup>1)</sup>	820 <sup>1)</sup>	1495	97.4	0.91	4024	1	6.8	2.7	31	3800	79	95	-	-
500...	by request															

### Note

- 1) Two parallel supply lines are required
- 2) Type B3 with terminal compartment EAR

The values are also valid for series BD..

# Inverter operation 50 Hz

Temperature class T4,  
ns = 1500 rpm, 2p = 4

73

40 °C ambient temperature. winding heating within heat class F

Operation on	Mains		Inverter										
			Self-ventilation										
Ventilation			Forced ventilation										
Torque trend	-	square decreasing	constant	constant	constant	constant	constant	constant	constant	constant	constant	constant	constant
Frequency	50 Hz	5-50 Hz	20-50 Hz	10-50 Hz	5-50 Hz	50-87 Hz <sup>1)</sup>	5-87 Hz <sup>1)</sup>						
Control range	-	1:10	1:2.5	1:5	1:10								
Speed range	-	150-1500 rpm	600-1500 rpm	300-1500 rpm	150-1500 rpm	1500-2610 rpm	150-2610 rpm						
Power/torque CD..	P <sub>2</sub> [kW]	P <sub>U</sub> [kW] 50 Hz	M <sub>U</sub> [Nm]	P <sub>U</sub> [kW] 50 Hz	M <sub>U</sub> [Nm]	P <sub>U</sub> [kW] 50 Hz	M <sub>U</sub> [Nm]	P <sub>U</sub> [kW] 50 Hz	M <sub>U</sub> [Nm]	P <sub>U</sub> [kW] 87 Hz	M <sub>U</sub> [Nm]	P <sub>U</sub> [kW] 50 Hz	P <sub>U</sub> [kW] 87 Hz
63M1-4	0.12	0.12	0.79	0.11	0.73	0.09	0.59	0.08	0.53	0.18	0.68	-	-
63M2-4	0.18	0.18	1.2	0.16	1.08	0.14	0.94	0.11	0.79	0.25	0.96	-	-
70M1-4	0.25	0.25	1.74	0.22	1.5	0.19	1.25	0.15	1	0.37	1.4	-	-
71M2-4	0.37	0.37	2.56	0.33	2.2	0.28	1.9	0.22	1.5	0.55	2	-	-
80M1-4	0.55	0.55	3.8	0.52	3.5	0.45	3	0.33	2.2	0.8	2.9	-	-
80M2-4	0.75	0.75	5.1	0.7	4.8	0.6	4	0.5	3.3	1.1	4	-	-
90S-4	1.1	1.1	7.5	1	6.7	0.9	6	0.75	5	1.6	5.9	-	-
90L-4	1.5	1.5	10.2	1.4	9.5	1.2	8	1	6.7	2.2	8	-	-
100L1-4	2.2	2.2	14.8	2	13	1.7	11	1.4	9.3	3.3	12	-	-
100L2-4	3	3	20.2	2.8	19	2.2	15	1.8	12	4.5	16	-	-
112M-4	4	4	26.6	3.6	24	3	20	2.5	16	6	22	-	-
132S-4	5.5	5.5	36.5	5	33	4.4	29	3.7	24	8	29	5.5	8
132M-4	7.5	7.5	50	7	46	6	39	5	33	11	40	7.5	10.5
160M-4	11	11	72	10	65	9	58	7.5	49	16	59	11	15
160L-4	15	15	98	13.5	88	12	78	10	65	21	79	15	20
180M-4	18.5	18 <sup>2)</sup>	118	98	111	15	97	12.5	81	26	95	18	25
180L-4	22	21 <sup>2)</sup>	137	20	130	18	117	15	97	30	110	21	29
200L-4	30	28 <sup>2)</sup>	183	27	176	24	156	21	136	40	146	28	37
225S-4	37	32 <sup>2)</sup>	208	31	201	29	188	26	168	49	179	32	45
225M-4	45	38 <sup>2)</sup>	247	37	240	35	227	32	207	60	220	38	55
250M-4	55	46 <sup>2)</sup>	298	45	291	43	278	41	265	70	256	46	65
280S-4	75	62 <sup>2)</sup>	400	60	386	58	373	55	354	95	348	62	88
280M-4	90	75 <sup>2)</sup>	482	73	470	70	450	66	424	110	402	75	105
315S-4	110	95 <sup>2)</sup>	610	90	577	88	564	83	532	140	512	95	130
315M-4	132	115	737	110	705	105	673	100	641	165	604	115	157
315L1-4	160	140	897	135	865	128	820	120	769	200	732	140	190
315L2-4	200	175	1122	165	1058	160	1026	150	961	250	915	175	240
315L3-4	250	215	1378	205	1314	200	1282	185	1186	310	1134	215	305
355L1-4	315	270	1731	260	1666	250	1602	235	1506	395	1445	270	385
355L2-4	355	305	1955	295	1891	285	1827	265	1698	440	1610	305	425
355L3-4	400	345	2209	335	2145	320	2048	300	1920	495	1820	345	480
400M-4	450	390	2500	375	2405	360	2307	340	2179	560	2050	390	540
400L-4	500	435	2778	415	2650	400	2553	380	2425	620	2274	435	600
450M-4	560	485	3097	465	2969	450	2873	425	2713	695	2549	485	670
450L-4	630	545	3480	525	3352	505	3224	475	3032	785	2879	545	755

## Notes

<sup>1)</sup> Higher frequencies by request.

<sup>2)</sup> For inverter operation with output filter and practically sinusoidal output voltage. or clock frequency  $\geq 4$  kHz. output like P<sub>2</sub>.

Output during operation at the inverter (guide values). torque curves page 59

Overload protection via temperature sensor

# IE1

## Mains operation 50 Hz

Temperature class T4,  
ns = 1000 rpm, 2p = 6

74

Size	Output P <sub>2</sub> [kW]	Rated current at		Speed n [rpm]	Efficiency η [%]	Power factor cos φ	Torque M [Nm]	Starting torque M <sub>A</sub> / M <sub>N</sub>	Starting current I <sub>A</sub> / I <sub>N</sub>	Break down torque M <sub>K</sub> / M <sub>N</sub>	Mass moment of inertia J [kgm <sup>2</sup> ]	Weight <sup>2)</sup>		Noise values with radial fan	
		400 V I [A]	500 V I [A]									m [kg]	L <sub>P</sub> [dB(A)]	L <sub>W</sub> [dB(A)]	
<b>CD..</b>					<b>IE1</b>	<b>Efficiency according to IEC60034-30</b>									
<b>71M2-6</b>	<b>0.25</b>	0.82	0.66	920	62	0.71	2.6	2.2	3.5	2.6	0.0012	17	44	56	
<b>80M1-6</b>	<b>0.37</b>	1.12	0.90	925	67	0.71	3.8	2.5	4.1	2.8	0.0019	24	44	56	
<b>80M2-6</b>	<b>0.55</b>	1.6	1.28	925	69	0.72	5.7	2.4	4	2.7	0.0025	25	44	56	
<b>90S-6</b>	<b>0.75</b>	2.15	1.72	910	70.2	0.75	7.9	1.8	3.4	2.1	0.0033	31	47	59	
<b>90L-6</b>	<b>1.1</b>	3.05	2.45	920	73	0.73	11.4	2	3.7	2.2	0.0046	35	47	59	
<b>100L-6</b>	<b>1.5</b>	3.75	3	945	77	0.75	15.2	2.5	4.9	3	0.0095	46	50	62	
<b>112M-6</b>	<b>2.2</b>	5.2	4.2	950	81	0.75	22.1	2.7	5.6	3.1	0.017	59	53	65	
<b>132S-6</b>	<b>3</b>	6.7	5.4	965	82.6	0.78	29.7	2.7	6.3	3.1	0.031	100	56	69	
<b>132M1-6</b>	<b>4</b>	8.7	7	965	83.6	0.79	39.6	2.6	6	3	0.037	104	56	69	
<b>132M2-6</b>	<b>5.5</b>	11.6	9.3	960	84.6	0.81	55	2.6	6.4	3	0.043	112	56	69	
<b>160M-6</b>	<b>7.5</b>	14.8	11.8	960	86.1	0.85	75	2.5	6.8	3.3	0.087	170	58	71	
<b>160L-6</b>	<b>11</b>	21	16.9	965	87.5	0.86	109	2.5	6.7	3.2	0.12	190	58	71	
<b>180L-6</b>	<b>15</b>	29	23	965	89.1	0.84	148	2.4	6.9	3.2	0.19	215	58	71	
<b>200L1-6</b>	<b>18.5</b>	35.5	28.5	975	89.7	0.84	181	1.9	6.3	2.7	0.28	270	58	71	
<b>200L2-6</b>	<b>22</b>	41.5	33	970	90.4	0.85	217	2.2	6.8	3	0.31	280	58	72	
<b>225M-6</b>	<b>30</b>	57	45.5	975	90.9	0.84	294	2.8	6.6	2.5	0.69	404	58	72	
<b>250M-6</b>	<b>37</b>	70	56	980	91.4	0.84	361	2.8	6.6	2.6	1.03	570	58	76	
<b>280S-6</b>	<b>45</b>	85	68	985	92.4	0.83	436	2.8	5.8	2.4	1.35	720	62	77	
<b>280M-6</b>	<b>55</b>	105	84	985	92.5	0.82	533	2.7	5.8	2.3	1.7	770	62	77	
<b>315S-6</b>	<b>75</b>	134	107	990	93	0.87	723	2.6	6.4	2.4	4.3	995	65	79	
<b>315M-6</b>	<b>90</b>	158	127	990	93.3	0.88	868	2.6	6.5	2.4	5	1050	65	79	
<b>315L1-6</b>	<b>110</b>	193	154	990	93.6	0.88	1061	2.7	6.5	2.5	6	1145	69	84	
<b>315L2-6</b>	<b>132</b>	230	185	990	93.8	0.88	1273	2.7	6.7	2.5	7.3	1265	69	84	
<b>315L3-6</b>	<b>160</b>	280	225	990	94.3	0.88	1543	2.6	6.8	2.5	8.3	1440	69	84	
<b>355M-6</b>	<b>200</b>	345	275	990	94.8	0.88	1929	1.8	6.7	2.7	11.3	1750	74	90	
<b>355L1-6</b>	<b>250</b>	430 <sup>1)</sup>	345	990	95.9	0.88	2411	1.8	6.7	2.7	13.8	1950	74	90	
<b>355L2-6</b>	<b>315</b>	540 <sup>1)</sup>	430 <sup>1)</sup>	990	96	0.88	3039	1.7	6.9	2.6	17.6	2300	74	90	
<b>400M-6</b>	<b>355</b>	595 <sup>1)</sup>	475 <sup>1)</sup>	994	96.6	0.89	3411	1.1	6.6	2.7	27	2850	78	94	
<b>400L-6</b>	<b>400</b>	670 <sup>1)</sup>	535 <sup>1)</sup>	994	96.6	0.89	3843	1.1	6.8	2.6	31	3230	78	94	
<b>450M-6</b>	<b>450</b>	755 <sup>1)</sup>	605 <sup>1)</sup>	995	96.6	0.89	4319	1.2	6.8	2.8	46	3500	78	94	
<b>450L-6</b>	<b>500</b>	835 <sup>1)</sup>	670 <sup>1)</sup>	995	97	0.89	4799	1.1	6.8	2.7	51	3800	78	94	
<b>500..</b>	by request														

**Note:**

- 1) Two parallel supply lines are required
- 2) Type B3 with terminal compartment EAR

The values are also valid for series BD..

# Inverter operation 50 Hz

Temperature class T4,  
ns = 1000 rpm, 2p = 6

75

40 °C Umgebungstemperatur, Wicklungserwärmung innerhalb der Wärmeklasse F

Operation on	Inverter												
	Mains	Self-ventilation										Inverter Forced ventilation	
Ventilation													
Torque trend	-	square decreasing	constant	constant	constant	constant	constant	constant	constant	constant	constant	constant	constant
Frequency	50 Hz	5-50 Hz	20-50 Hz	10-50 Hz	5-50 Hz	50-87 Hz <sup>1)</sup>	5-87 Hz <sup>1)</sup>						
Control range	-	1:10	1:2.5	1:5	1:10								
Speed range	-	100-1000 rpm	400-1000 rpm	200-1000 rpm	100-1000 rpm	1000-1740 rpm	100-1740 rpm						
Power/torque CD..	P2 [kW]	P <sub>U</sub> [kW] 50 Hz	M <sub>U</sub> [Nm]	P <sub>U</sub> [kW] 50 Hz	M <sub>U</sub> [Nm]	P <sub>U</sub> [kW] 50 Hz	M <sub>U</sub> [Nm]	P <sub>U</sub> [kW] 50 Hz	M <sub>U</sub> [Nm]	P <sub>U</sub> [kW] 87 Hz	M <sub>U</sub> [Nm]	P <sub>U</sub> [kW] 50 Hz	P <sub>U</sub> [kW] 87 Hz
71M2-6	0.25	0.25	2.6	0.22	2.2	0.18	1.8	0.16	1.6	0.37	2	-	-
80M1-6	0.37	0.37	3.8	0.33	3.4	0.27	2.7	0.22	2.2	0.55	3	-	-
80M2-6	0.55	0.55	5.7	0.5	5.1	0.4	4	0.33	3.3	0.8	4.4	-	-
90S-6	0.75	0.75	7.9	0.65	6.7	0.55	5.5	0.42	4.2	1.1	6	-	-
90L-6	1.1	1.1	11.4	0.9	9.2	0.8	8	0.6	6	1.6	8.8	-	-
100L-6	1.5	1.5	15.2	1.4	14	1.1	11	0.9	9	2.2	12	-	-
112M-6	2.2	2.2	22.1	2	20	1.7	17	1.3	13	3.3	18	-	-
132S1-6	3	3	29.7	2.7	27	2.2	22	1.8	18	4.5	25	3	4.2
132M1-6	4	4	40	3.5	35	3	30	2.5	25	6	33	4	5.5
132M2-6	5.5	5.5	55	4.8	48	4	40	3.3	33	8	44	5.5	7.6
160M-6	7.5	7.5	75	7	69	6	59	5	49	11	60	7.5	10.5
160L-6	11	11	109	10	98	9	88	7.5	73	16	88	11	15
180L-6	15	15	148	13	128	12	118	10	98	21	115	15	20
200L1-6	18.5	17.5 <sup>2)</sup>	171	16	157	14	137	12	118	26	143	17.5	24
200L2-6	22	20 <sup>2)</sup>	196	19	186	17	167	15	147	30	165	20	28
225M-6	30	27 <sup>2)</sup>	262	25	242	23	223	21	204	40	220	27	37
250M-6	37	33 <sup>2)</sup>	320	31	301	29	281	26	252	49	269	33	45
280S-6	45	40 <sup>2)</sup>	386	37	357	35	338	32	309	60	329	40	55
280M-6	55	47 <sup>2)</sup>	453	45	434	43	415	41	396	70	384	47	65
315S-6	75	65 <sup>2)</sup>	627	62	598	58	559	56	540	95	521	65	88
315M-6	90	78 <sup>2)</sup>	752	73	704	70	675	68	656	110	604	78	105
315L1-6	110	95 <sup>2)</sup>	916	90	868	88	849	85	820	140	768	95	130
315L2-6	132	115	1109	110	1061	105	1013	100	965	165	906	115	157
315L3-6	160	140	1351	135	1302	128	1235	120	1158	200	1098	140	190
355M-6	200	170	1640	165	1592	160	1543	150	1447	250	1372	170	240
355L1-6	250	215	2074	205	1978	200	1929	190	1833	310	1701	215	305
355L2-6	315	270	2605	260	2508	250	2412	235	2267	395	2168	270	385
400M-6	355	305	2942	295	2846	285	2749	265	2556	440	2115	305	425
400L-6	400	345	3328	335	3232	320	3087	300	2894	495	2717	345	480
450M-6	450	390	3762	375	3617	360	3473	340	3280	560	3074	390	540
450L-6	500	435	4196	415	4003	400	3859	375	3618	620	3404	435	600

## Notes

<sup>1)</sup> Higher frequencies by request.

<sup>2)</sup> For inverter operation with output filter and practically sinusoidal output voltage, or clock frequency  $\geq 4$  kHz. output like P<sub>2</sub>.

Output during operation at the inverter (guide values), torque curves page 59

Overload protection via temperature sensor

ATTENTION: From 01.07.2021, motors with efficiency classes IE1 and IE2 may only be supplied to the EU area as replacement motors for identical ATB motors that are already in operation.

# IE1

## Mains operation 50 Hz

Temperature class T4,  
ns = 750 rpm, 2p = 8

76

Size	Output P <sub>2</sub> [kW]	Rated current at		Speed n [rpm]	Efficiency η [%]	Power factor cos φ	Torque M [Nm]	Starting torque M <sub>A</sub> / M <sub>N</sub>	Starting current I <sub>A</sub> / I <sub>N</sub>	Breakdown torque M <sub>K</sub> / M <sub>N</sub>	Mass moment of inertia J [kgm <sup>2</sup> ]	Weight <sup>2)</sup> m [kg]	Noise values with radial fan		
		400 V I [A]	500 V I [A]										L <sub>P</sub> [dB(A)]	L <sub>W</sub> [dB(A)]	
<b>IE1 Efficiency according to IEC 60034-30</b>															
CD..															
71M2-8	0.12	0.54	0.43	680	49.5	0.65	1.7	1.9	2.6	2.4	0.0012	17	41	53	
80M1-8	0.18	0.74	0.59	690	54	0.65	2.5	2.2	3.2	2.6	0.0019	24	42	54	
80M2-8	0.25	0.96	0.77	690	58.5	0.64	3.5	2.2	3.2	2.5	0.0025	25	42	54	
90S-8	0.37	1.36	1.10	690	60	0.65	5.1	1.8	3	2.2	0.0033	31	46	58	
90L-8	0.55	1.94	1.55	690	63	0.65	7.6	1.8	3.1	2.2	0.0046	35	46	58	
100L1-8	0.75	2.45	1.96	710	67	0.66	10.1	2.4	4	2.6	0.008	44	49	61	
100L2-8	1.1	3.15	2.5	695	69	0.73	15.1	2	3.8	2.4	0.0095	46	49	61	
112M-8	1.5	4.15	3.3	710	76	0.67	20.2	2.2	4.6	2.8	0.017	59	52	64	
132S-8	2.2	5.2	4.2	695	77	0.79	30	2	4.1	2.3	0.029	97	53	66	
132M-8	3	7	5.6	705	80.5	0.77	41	2.4	4.6	2.7	0.036	113	53	66	
160M1-8	4	8.8	7.1	715	83.8	0.78	53	1.8	4.6	2.3	0.071	157	54	67	
160M2-8	5.5	12.2	9.7	720	84.7	0.77	73	2.1	5.4	2.8	0.105	170	54	67	
160L-8	7.5	16.5	13.2	720	85.2	0.77	99	2.2	5.6	2.9	0.136	190	54	67	
180L-8	11	23	18.5	725	87.1	0.79	145	2.4	6.4	3	0.22	215	56	69	
200L-8	15	30.5	24.5	730	88.5	0.80	196	2.4	6.9	3.2	0.4	280	56	70	
225S-8	18.5	38	30.5	730	89	0.79	242	2.2	6.3	3	0.56	372	57	71	
225M-8	22	45	36	730	89.5	0.79	288	2.2	6.6	3	0.69	404	57	71	
250M-8	30	59	47	735	90.1	0.82	390	2	6.8	3	1.2	550	58	72	
280S-8	37	71	57	735	91.1	0.82	481	2.1	6.2	2.8	1.9	740	61	75	
280M-8	45	87	69	735	91.3	0.82	585	2	6.3	2.6	2.3	800	61	75	
315S-8	55	104	83	740	91.8	0.83	710	2.7	6	2.5	4.3	995	68	83	
315M-8	75	141	113	740	92.6	0.83	968	2.8	6.3	2.6	5	1050	68	83	
315L1-8	90	169	135	740	92.8	0.83	1161	2.9	6.6	2.7	6	1145	68	83	
315L2-8	110	210	167	740	93	0.82	1420	2.9	6.8	2.7	7.3	1265	68	83	
315L3-8	132	250	200	735	93.1	0.82	1715	2.8	6.3	2.6	8.3	1440	68	83	
355M-8	160	295	235	740	95.1	0.83	2065	1.7	6.4	2.7	11.4	1750	70	86	
355L1-8	200	370	295	745	95.6	0.82	2564	1.6	6.6	2.6	13.9	1950	70	86	
355L2-8	250	460 <sup>1)</sup>	370	745	95.6	0.82	3205	1.4	6.1	2.6	17.7	2300	70	86	
400M-8	315	570 <sup>1)</sup>	455 <sup>1)</sup>	745	96.2	0.83	4038	1.2	6.2	2.7	30	3100	73	89	
400L-8	355	640 <sup>1)</sup>	515 <sup>1)</sup>	745	96.3	0.83	4551	1	6.1	2.6	34	3440	73	89	
450M-8	400	710 <sup>1)</sup>	570 <sup>1)</sup>	745	96.6	0.84	5128	1	6.1	2.8	51	3750	74	90	
450L-8	450	800 <sup>1)</sup>	640 <sup>1)</sup>	745	96.7	0.84	5768	1	6.1	2.8	57	4050	74	90	
500..	by request														

**Note:**

- 1) Two parallel supply lines are required
- 2) Type B3 with terminal compartment type EAR

The values are also valid for series BD..

# Inverter operation 50 Hz

Temperature class T4,  
ns = 750 rpm, 2p = 8

77

40 °C ambient temperature. winding heating within heat class F

Operation on	Inverter												
	Mains	Self-ventilation										Forced ventilation	
Ventilation													
Torque trend	-	square decreasing	constant	constant	constant	constant	constant	constant	constant	constant	constant	constant	constant
Frequency	50 Hz	5-50 Hz	20-50 Hz	10-50 Hz	5-50 Hz	50-87 Hz <sup>1)</sup>	5-87 Hz <sup>1)</sup>						
Control range	-	1:10	1:2.5	1:5	1:10								
Speed range	-	100-1000 rpm	400-1000 rpm	200-1000 rpm	100-1000 rpm	1000-1740 rpm	100-1740 rpm						
Power/torque CD..	P2 [kW]	P <sub>U</sub> [kW] 50 Hz	M <sub>U</sub> [Nm]	P <sub>U</sub> [kW] 50 Hz	M <sub>U</sub> [Nm]	P <sub>U</sub> [kW] 50 Hz	M <sub>U</sub> [Nm]	P <sub>U</sub> [kW] 50 Hz	M <sub>U</sub> [Nm]	P <sub>U</sub> [kW] 87 Hz	M <sub>U</sub> [Nm]	P <sub>U</sub> [kW] 50 Hz	P <sub>U</sub> [kW] 87 Hz
71M2-8	0.12	0.12	1.7	0.11	1.5	0.1	1.4	0.08	1.1	0.18	1.3	-	-
80M1-8	0.18	0.18	2.5	0.16	2.2	0.13	1.7	0.11	1.5	0.25	1.8	-	-
80M2-8	0.25	0.25	3.5	0.22	3	0.18	2.4	0.16	2.2	0.37	2.7	-	-
90S-8	0.37	0.37	5.1	0.33	4.4	0.27	3.6	0.22	3	0.55	4	-	-
90L-8	0.55	0.55	7.6	0.5	6.7	0.4	5.4	0.33	4.4	0.8	5.9	-	-
100L1-8	0.75	0.75	10.1	0.65	8.7	0.55	7.4	0.42	5.6	1.1	8	-	-
100L2-8	1.1	1.1	15.1	0.9	12	0.8	11	0.6	8.1	1.6	12	-	-
112M-8	1.5	1.5	20.2	1.4	19	1.1	15	0.9	12	2.2	16	-	-
132S-8	2.2	2.2	30	2	27	1.7	23	1.3	17	3.3	24	2.2	3.1
132M-8	3	3	41	2.7	36	2.2	29	1.8	24	4.5	33	3	4.2
160M1-8	4	4	53	3.5	46	3	40	2.5	33	6	44	4	5.5
160M2-8	5.5	5.5	73	4.8	64	4	52	3.3	44	8	59	5.5	7.6
160L-8	7.5	7.5	99	7	92	5.5	72	4.5	59	11	80	7.5	10.5
180L-8	11	11	145	10	131	8	104	7	91	16	117	11	15
200L-8	15	15	196	13	170	11	143	10	130	21	154	15	20
225S-8	18.5	18.5	242	16	208	14	181	12	155	26	190	18.5	25
225M-8	22	22	288	19	245	17	219	15	194	30	220	22	29
250M-8	30	27 <sup>2)</sup>	348	25	323	23	297	21	271	40	293	27	37
280S-8	37	33 <sup>2)</sup>	426	31	400	29	374	26	336	49	359	33	45
280M-8	45	40 <sup>2)</sup>	516	37	478	35	452	32	413	60	439	40	55
315S-8	55	48 <sup>2)</sup>	619	45	581	43	555	41	529	70	512	48	65
315M-8	75	65 <sup>2)</sup>	839	62	800	58	749	56	723	95	695	65	88
315L1-8	90	78 <sup>2)</sup>	1007	73	942	70	903	68	878	110	805	78	105
315L2-8	110	95 <sup>2)</sup>	1226	90	1161	88	1136	85	1097	140	1025	95	130
315L3-8	132	115	1484	110	1420	105	1309	100	1247	165	1027	115	157
355M-8	160	140	1807	135	1743	128	1596	120	1496	200	1464	140	190
355L1-8	200	170	2194	165	2129	160	1994	150	1870	250	1830	170	240
355L2-8	250	215	2775	205	2646	200	2493	190	2368	310	2269	215	305
400M-8	315	270	3484	260	3355	250	3116	235	2929	395	2891	270	385
400L-8	355	305	3935	295	3807	285	3553	265	3303	440	3220	305	425
450M-8	400	345	4452	335	4323	320	3989	300	3740	495	3622	345	480
450L-8	450	390	5033	375	4839	360	4488	340	4239	560	4098	390	540

## Notes

<sup>1)</sup> Higher frequencies by request.

<sup>2)</sup> For inverter operation with output filter and practically sinusoidal output voltage. or clock frequency  $\geq 4$  kHz. output like P<sub>2</sub>.

Output during operation at the inverter (guide values). torque curves page 59

Overload protection via temperature sensor

# IE1 Mains operation 60 Hz

Temperature class T4,  
ns = 3600 rpm, 2p = 2

78

Size	Output	Rated current at		Speed n [rpm]	Efficiency $\eta$ [%]	Power factor $\cos \varphi$	Torque M [Nm]	Starting torque $M_A / M_N$	Starting current $I_A / I_N$	Break down torque $M_k / M_N$	Mass moment of inertia J [kgm <sup>2</sup> ]	Weight <sup>2)</sup> m [kg]	Noise values with radial fan		Noise values with axial fan	
		460 V I [A]	690 V I [A]										$L_P$ [dB(A)]	$L_W$ [dB(A)]	$L_P$ [dB(A)]	$L_W$ [dB(A)]
<b>CD.. Efficiency according to manufacturer's standard</b>																
63M1-2	0.21	0.6	0.4	3485	66	0.67	0.59	4.6	6.8	6.5	0.00028	16	53	65	-	-
63M2-2	0.29	0.69	0.46	3430	70	0.75	0.83	3.4	5.8	4.7	0.00028	16	53	65	-	-
71M1-2	0.44	0.92	0.61	3360	71.5	0.84	1.26	2.7	5.2	3.5	0.00028	16	56	68	-	-
71M2-2	0.65	1.38	0.92	3370	72	0.82	1.87	2.8	5.5	3.6	0.00039	17	56	68	-	-
80M1-2	0.86	1.72	1.15	3350	74.5	0.84	2.57	2.7	4.8	3.3	0.00058	24	60	72	-	-
80M2-2	1.26	2.45	1.65	3385	78	0.82	3.73	2.8	5.5	3.5	0.0008	25	60	72	-	-
90S-2	1.8	3.5	2.25	3410	77.8	0.86	5	2.9	5.9	3.2	0.0013	31	65	77	-	-
90L-2	2.5	4.5	3	3420	82	0.85	7.4	3	6.3	3.5	0.0018	35	65	77	-	-
100L-2	3.6	6.3	4.2	3420	82	0.87	10.1	2.7	6.8	3.3	0.0029	45	68	80	-	-
112M-2	4.8	8.1	5.4	3455	85	0.88	13.3	2.3	6.5	3.1	0.0051	53	68	80	-	-
132S1-2	6.6	11.1	7.4	3470	85.5	0.87	18.2	2.5	6.4	3.3	0.0089	95	68	81	60	73
132S2-2	9	15	10	3490	86.5	0.87	24.6	2.7	6.8	3.5	0.0125	100	68	81	60	73
160M1-2	12.8	20.5	13.5	3510	89	0.89	36	2.8	6.6	3.2	0.032	163	71	84	61	74
160M2-2	17.5	27	18.1	3505	89	0.91	49	2.8	6.8	3.2	0.043	173	71	84	61	74
160L-2	22	33	22	3510	91	0.92	60	2.6	6.8	3.1	0.052	188	71	84	61	74
180M-2	26	39	26	3510	91.2	0.92	72	2.5	6.9	3	0.075	196	75	88	64	77
200L1-2	36	55	36.5	3545	92	0.90	97	2.6	7.2	2.9	0.13	254	77	91	65	79
200L2-2	43	64	42.5	3545	92.5	0.91	120	2.7	7.2	3	0.16	278	77	91	65	79
225M-2	52	79	53	3550	92.8	0.89	145	2.5	7.1	3	0.24	400	78	92	66	80
250M-2	64	97	65	3565	93.2	0.89	177	2.4	7.1	2.8	0.4	545	81	95	70	84
280S-2	87	131	87	3565	93.6	0.89	241	2.2	6.8	2.7	0.65	700	82	96	72	86
280M-2	105	156	104	3565	93.8	0.90	289	2.4	6.8	2.8	0.78	762	82	96	72	86
315S-2	121	182	121	3570	94	0.89	353	2.1	6.8	2.5	1.4	960	82	96	73	88
315M-2	145	215	145	3570	94.3	0.89	424	2.2	7.2	2.6	1.6	1025	82	96	73	88
315L1-2	176	260	173	3570	94.5	0.90	514	2.5	7.3	2.8	1.9	1065	82	96	73	88
315L2-2	220	325	215	3575	94.7	0.90	641	2.4	7.3	2.7	2.2	1270	82	96	73	88
315L3-2	275	395	260	3575	95.5	0.92	801	1.8	7.6	2.8	2.8	1420	82	96	73	88
355L1-2	345	490 <sup>1)</sup>	325	3575	96.1	0.92	1009	1.6	7.1	3	4.5	1900	87	103	75	91
355L2-2	390	545 <sup>1)</sup>	365	3580	96.3	0.93	1136	1.5	7.3	2.8	5	2050	87	103	75	91
355L3-2	440	615 <sup>1)</sup>	410 <sup>1)</sup>	3580	96.3	0.93	1280	1.4	7.4	2.8	5.5	2350	87	103	75	91
400L-2	495	685 <sup>1)</sup>	455 <sup>1)</sup>	3585	96.5	0.94	1437	1.15	7.6	3	8.5	2910	87	103	81	97

**Note:**

- 1) Two parallel supply lines are required
- 2) Type B3 with terminal compartment type EAR

The values are also valid for series BD..

# Inverter operation 60 Hz

Temperature class T4,  
ns = 3600 rpm, 2p = 2

79

40 °C ambient temperature. winding heating within heat class F

Operation on	Mains		Inverter								
			Self-ventilation				Forced ventilation				
Ventilation											
Torque trend	-	square decreasing	constant	constant	constant	constant	constant	constant	constant	constant	constant
Frequency	60 Hz	6-60 Hz	24-60 Hz	12-60 Hz	6-60 Hz	6-60 Hz	6-60 Hz	6-60 Hz	6-60 Hz	6-60 Hz <sup>1)</sup>	6-60 Hz <sup>1)</sup>
Control range	-	1:10	1:2.5	1:5	1:10	1:10	1:10	1:10	1:10	1:10	1:10
Speed range	-	360-3600 rpm	1440-3600 rpm	720-3600 rpm	360-3600 rpm	360-3600 rpm	360-3600 rpm	360-3600 rpm	360-3600 rpm	360-3600 rpm	360-3600 rpm
Power/torque CD..	P <sub>2</sub> [kW]	P <sub>U</sub> [kW] 60 Hz	M <sub>U</sub> [Nm]	P <sub>U</sub> [kW] 60 Hz	M <sub>U</sub> [Nm]	P <sub>U</sub> [kW] 60 Hz	M <sub>U</sub> [Nm]	P <sub>U</sub> [kW] 60 Hz	M <sub>U</sub> [Nm]	P <sub>U</sub> [kW] 60 Hz	M <sub>U</sub> [Nm]
63M1-2	0.21	0.21	0.58	0.19	0.52	0.16	0.44	0.14	0.38	-	-
63M2-2	0.29	0.29	0.81	0.26	0.72	0.22	0.61	0.17	0.46	-	-
71M1-2	0.44	0.44	1.25	0.42	1.19	0.36	1.01	0.26	0.72	-	-
71M2-2	0.65	0.65	1.83	0.61	1.72	0.53	1.48	0.39	1.08	-	-
80M1-2	0.86	0.86	2.45	0.8	2.25	0.69	1.94	0.57	1.59	-	-
80M2-2	1.26	1.26	3.55	1.15	3.25	1.03	2.85	0.86	2.4	-	-
90S-2	1.8	1.8	5	1.7	4.75	1.4	3.85	1.2	3.3	-	-
90L-2	2.5	2.5	7	2.3	6.4	1.9	5.2	1.6	4.4	-	-
100L-2	3.6	3.6	10.1	3.2	8.9	2.6	7.2	2.2	6	-	-
112M-2	4.8	4.8	13.3	4.4	12.1	3.8	10.4	3	8.2	-	-
132S1-2	6.6	6.6	18.2	6	16.5	5.4	14.8	4.4	12	6.6	18.2
132S2-2	9	9	24.6	8.4	23	7.2	19.6	6	16.2	9	24.6
160M1-2	12.8	12.8	34.8	11.6	31.5	10.5	28.5	8.7	23.5	12.8	34.8
160M2-2	17.5	16.9 <sup>2)</sup>	46	15.2	41.5	14	38	11.7	31.5	16.9	46
160L-2	22	20.8 <sup>2)</sup>	57	19	52	17.8	48	14.9	40	20.8	57
180M-2	26	25 <sup>2)</sup>	68	24	65	21	57	18	48.5	25	68
200L1-2	36	34 <sup>2)</sup>	92	32	86	29	78	26	70	34	92
200L2-2	43	37 <sup>2)</sup>	99	36	97	33	89	31	83	37	99
225M-2	52	44 <sup>2)</sup>	118	43	115	39	105	37	99	44	118
250M-2	64	55 <sup>2)</sup>	147	52	139	50	134	48	128	55	147
280S-2	87	72 <sup>2)</sup>	193	70	187	67	179	64	171	72	193
280M-2	105	88 <sup>2)</sup>	235	85	227	82	219	78	208	88	235
315S-2	121	105 <sup>2)</sup>	281	99	264	97	259	94	251	105	281
315M-2	145	126	337	121	323	115	307	110	294	126	337
315L1-2	176	154	412	149	398	141	377	132	352	154	412
315L2-2	220	193	515	182	486	176	469	165	440	193	515
315L3-2	275	237	632	226	603	220	587	204	544	237	632
355L1-2	345	296	790	285	760	274	731	257	685	296	790
355L2-2	390	335	893	324	863	313	834	291	775	335	893
355L3-2	440	380	1013	369	983	352	938	330	879	380	1013
400L-2	495	429	1142	412	1097	396	1054	374	995	429	1142

## Notes

<sup>1)</sup> Higher frequencies by request.

<sup>2)</sup> For inverter operation with output filter and practically sinusoidal output voltage. or clock frequency  $\geq 4$  kHz. output like P<sub>2</sub>.

Output during operation at the inverter (guide values). torque curves page 60

Overload protection via temperature sensor

# IE1 Mains operation 60 Hz

Temperature class T4,  
ns = 1800 rpm, 2p = 4

80

Size	Output P <sub>2</sub> [kW]	Rated current at		Speed n [rpm]	Efficiency η [%]	Power factor cos φ	Torque M [Nm]	Starting torque M <sub>A</sub> / M <sub>N</sub>	Starting current I <sub>A</sub> / I <sub>N</sub>	Break down torque M <sub>K</sub> / M <sub>N</sub>	Mass-moment of inertia J [kgm <sup>2</sup> ]	Weight <sup>2)</sup> m [kg]	Noise values with radial fan		Noise values with axial fan		
		460 V I [A]	690 V I [A]										L <sub>P</sub> [dB(A)]	L <sub>W</sub> [dB(A)]	L <sub>P</sub> [dB(A)]	L <sub>W</sub> [dB(A)]	
<b>Efficiency according to manufacturer's standard</b>																	
CD..																	
63M1-4	0.14	0.44	0.29	1735	67	0.60	0.77	3.9	5.6	3.9	0.00046	16	48	60	-	-	
63M2-4	0.21	0.54	0.36	1700	70	0.70	1.18	2.7	4.7	2.7	0.00046	16	48	60	-	-	
71M1-4	0.3	0.69	0.46	1645	68.5	0.80	1.74	2	3.9	2.3	0.00046	16	49	61	-	-	
71M2-4	0.44	0.97	0.65	1655	71	0.80	2.54	2.2	3.9	2.3	0.00063	17	49	61	-	-	
80M1-4	0.63	1.37	0.92	1655	72	0.80	3.6	2	3.8	2.3	0.00092	24	50	62	-	-	
80M2-4	0.86	1.81	1.21	1680	75.5	0.79	4.9	2.1	4.5	2.5	0.0013	25	50	62	-	-	
90S-4	1.3	2.6	1.72	1680	76	0.83	7.4	2.1	4.8	2.5	0.0021	31	53	65	-	-	
90L-4	1.8	3.5	2.3	1685	79	0.82	10.2	2.3	5	2.7	0.0029	35	53	65	-	-	
100L1-4	2.6	5.1	3.4	1705	80	0.80	14.6	2.4	5.4	2.8	0.0046	44	57	69	-	-	
100L2-4	3.6	6.7	4.5	1700	81.7	0.82	20.2	2.3	5.5	2.7	0.0056	46	57	69	-	-	
112M-4	4.8	8.4	5.6	1720	85	0.84	26.7	2.7	6.8	3.2	0.0110	59	59	71	-	-	
132S-4	6.6	11.3	7.5	1730	86.5	0.85	36.4	2.5	6.4	2.7	0.0220	100	62	75	59	72	
132M-4	8.5	14.1	9.4	1730	88	0.86	47	2.7	6.5	2.8	0.030	110	62	75	59	72	
160M-4	12.6	21	13.9	1750	89.5	0.85	69	2.5	6.6	2.8	0.057	168	67	80	60	73	
160L-4	17.2	28	18.6	1745	90	0.86	94	2.8	6.7	3.1	0.079	184	67	80	60	73	
180M-4	22	36	24	1750	91	0.84	120	2.9	6.7	3	0.13	198	65	78	61	74	
180L-4	26	44	28.5	1750	91.5	0.84	142	3	6.9	3	0.155	217	65	78	61	74	
200L-4	34.5	53	35.5	1750	92.2	0.88	188	2.6	6.8	2.9	0.25	274	66	80	62	76	
225S-4	43	65	44	1760	92.6	0.88	233	2.7	6.7	2.6	0.4	372	68	82	64	78	
225M-4	52	80	53	1765	92.8	0.88	281	2.7	6.5	2.6	0.48	402	68	82	64	78	
250M-4	64	97	65	1765	93.2	0.89	346	2.9	7.1	2.9	0.75	573	70	84	68	82	
280S-4	87	135	90	1775	93.8	0.86	468	2.6	6.8	2.5	1.25	740	74	88	71	85	
280M-4	105	163	109	1775	94	0.86	565	2.8	6.9	2.6	1.48	820	74	88	71	85	
315S-4	121	190	126	1780	94.2	0.85	649	2.6	7.2	2.6	2.2	1040	76	91	72	87	
315M-4	145	225	151	1780	94.4	0.85	778	2.7	7.2	2.7	2.7	1120	76	91	72	87	
315L1-4	176	270	181	1780	94.7	0.86	944	2.8	7.3	2.7	3.1	1210	76	91	72	87	
315L2-4	220	340	225	1780	94.9	0.87	1180	2.8	7.3	2.7	3.9	1430	76	91	72	87	
315L3-4	275	410 <sup>1)</sup>	275	1785	96.2	0.87	1471	1.8	7.7	2.8	4.6	1565	76	91	72	87	
355L1-4	345	500 <sup>1)</sup>	335	1790	96.3	0.90	1841	1.5	7.3	2.8	6.1	2050	78	94	74	90	
355L2-4	390	565 <sup>1)</sup>	375	1790	96.6	0.90	2081	1.6	7.3	3	6.7	2200	78	94	74	90	
355L3-4	440	635 <sup>1)</sup>	420 <sup>1)</sup>	1790	97	0.90	2347	1.5	7.4	3	7.4	2430	78	94	74	90	
400M-4	495	705 <sup>1)</sup>	470 <sup>1)</sup>	1794	97	0.91	2635	1.1	7.7	2.8	18	2850	84	100	-	-	
400L-4	550	780 <sup>1)</sup>	520 <sup>1)</sup>	1794	97.1	0.91	2928	1.1	7.7	2.8	20	3230	84	100	-	-	
450M-4	610	865 <sup>1)</sup>	575 <sup>1)</sup>	1794	97.2	0.91	3247	1	7.2	2.8	26	3500	85	101	-	-	
450L-4	690	975 <sup>1)</sup>	650 <sup>1)</sup>	1794	97.4	0.91	3673	1	7.2	2.8	31	3800	85	101	-	-	
500..	by request																

## Note

- 1) Two parallel supply lines are required
- 2) Type B3 with terminal compartment type EAR

The values are also valid for series BD..

# Inverter operation 60 Hz

Temperature class T4,  
ns = 1800 rpm, 2p = 4

81

40 °C ambient temperature. winding heating within heat class F

Operation on	Mains		Inverter								
	Self-ventilation		Self-ventilation				Forced ventilation				
Ventilation											
Torque trend	-	square decreasing	constant	constant	constant	constant	constant	constant	constant	constant	constant
Frequency	60 Hz	6-60 Hz	24-60 Hz	12-60 Hz	6-60 Hz	6-60 Hz	6-60 Hz	6-60 Hz	6-60 Hz	6-60 Hz <sup>1)</sup>	6-60 Hz <sup>1)</sup>
Control range	-	1:10	1:2.5	1:5	1:10	1:10	1:10	1:10	1:10	1:10	1:10
Speed range	-	180-1800 rpm	720-1800 rpm	360-1800 rpm	180-1800 rpm	180-1800 rpm	180-1800 rpm	180-1800 rpm	180-1800 rpm	180-1800 rpm	180-1800 rpm
Power/torque CD..	P <sub>2</sub> [kW]	P <sub>U</sub> [kW] 60 Hz	M <sub>U</sub> [Nm]	P <sub>U</sub> [kW] 60 Hz	M <sub>U</sub> [Nm]	P <sub>U</sub> [kW] 60 Hz	M <sub>U</sub> [Nm]	P <sub>U</sub> [kW] 60 Hz	M <sub>U</sub> [Nm]	P <sub>U</sub> [kW] 60 Hz	M <sub>U</sub> [Nm]
63M1-4	0.14	0.14	0.77	0.13	0.71	0.11	0.6	0.09	0.49	-	-
63M2-4	0.21	0.21	1.18	0.19	1.06	0.16	0.89	0.13	0.71	-	-
70M1-4	0.3	0.3	1.74	0.26	1.49	0.23	1.31	0.18	1.01	-	-
71M2-4	0.44	0.44	2.55	0.39	2.25	0.33	1.86	0.26	1.45	-	-
80M1-4	0.63	0.63	3.65	0.6	3.45	0.52	2.95	0.38	2.1	-	-
80M2-4	0.86	0.86	4.9	0.8	4.55	0.69	3.85	0.57	3.15	-	-
90S-4	1.3	1.3	7.4	1.2	6.8	1.1	6.2	0.9	5	-	-
90L-4	1.8	1.8	10.2	1.7	9.6	1.4	7.8	1.2	6.6	-	-
100L1-4	2.6	2.6	14.6	2.4	13.4	2	11.1	1.7	9.3	-	-
100L2-4	3.6	3.6	20	3.4	19	2.6	14.4	2.2	12.1	-	-
112M-4	4.8	4.8	26.5	4.3	24	3.6	19.8	3	16.4	-	-
132S-4	6.6	6.6	36.5	6	33	5.3	29	4.4	24	6.6	36.5
132M-4	8.5	8.5	47	7.9	43.5	6.8	37	5.7	31	8.5	47
160M-4	12.6	12.6	69	11.5	63	10.3	56	8.6	46.5	12.6	69
160L-4	17.2	17.2	94	15.5	85	13.8	75	11.5	62	17.2	94
180M-4	22	121.4 <sup>2)</sup>	117	20.2	109	17.8	97	14.9	81	21.4	117
180L-4	26	24.8 <sup>2)</sup>	136	23.6	128	21.3	117	17.7	96	24.8	136
200L-4	34.5	32.2 <sup>2)</sup>	174	31.1	169	27.6	149	24.2	130	32.2	174
225S-4	43	37 <sup>2)</sup>	200	36	195	34	184	30	162	37	200
225M-4	52	44 <sup>2)</sup>	237	43	232	40	215	37	199	44	237
250M-4	64	54 <sup>2)</sup>	291	52	280	50	269	48	258	54	291
280S-4	87	72 <sup>2)</sup>	386	70	376	67	359	64	343	72	386
280M-4	105	88 <sup>2)</sup>	472	85	456	82	440	77	413	8	472
315S-4	121	105 <sup>2)</sup>	563	99	530	97	519	91	487	105	563
315M-4	145	126	675	121	648	115	616	110	589	126	675
315L1-4	176	154	825	149	798	141	755	132	703	154	825
315L2-4	220	193	1034	182	975	176	942	165	883	193	1034
315L3-4	275	237	1267	226	1207	220	1175	204	1089	237	1267
355L1-4	345	296	1578	285	1519	274	1460	257	1369	296	1578
355L2-4	390	335	1786	324	1727	313	1668	291	1550	335	1786
355L3-4	440	380	2026	369	1967	352	1876	330	1758	380	2026
400M-4	495	429	2283	413	2197	396	2107	374	1989	429	2283
400L-4	550	479	2549	457	2431	440	2341	418	2223	479	2549
450M-4	610	528	2809	507	2697	490	2607	463	2463	528	2809
450L-4	690	597	3177	575	3059	553	2942	520	2766	597	3177

## Notes

<sup>1)</sup> Higher frequencies by request.

<sup>2)</sup> For inverter operation with output filter and practically sinusoidal output voltage. or clock frequency  $\geq 4$  kHz. output like P<sub>2</sub>.

Output during operation at the inverter (guide values). torque curves page 61

Overload protection via temperature sensor

# IE1

## Mains operation 60 Hz

Temperature class T4,  
ns = 1200 rpm, 2p = 6

82

Size	Output P <sub>2</sub> [kW]	Rated current at		Speed n [rpm]	Efficiency η [%]	Power factor cos φ	Torque M [Nm]	Starting torque M <sub>A</sub> / M <sub>N</sub>	Starting current I <sub>A</sub> / I <sub>N</sub>	Break-down torque M <sub>K</sub> / M <sub>N</sub>	Mass moment of inertia J [kgm <sup>2</sup> ]	Weight <sup>2)</sup> m [kg]	Noise values with radial fan	
		460 V I [A]	690 V I [A]										L <sub>P</sub> [dB(A)]	L <sub>W</sub> [dB(A)]
<b>CD.. Efficiency according to manufacturer's standard</b>														
71M2-6	0.3	0.86	0.57	1105	62	0.71	2.6	2.2	3.5	2.6	0.0012	17	48	60
80M1-6	0.42	1.11	0.74	1110	67	0.71	3.6	2.5	4.1	2.8	0.0019	24	48	60
80M2-6	0.64	1.62	1.08	1110	69	0.72	5.5	2.4	4	2.7	0.0025	25	51	60
90S-6	0.9	2.15	1.43	1090	70.2	0.75	7.9	1.8	3.4	2.1	0.0033	31	51	63
90L-6	1.3	3.05	2.05	1105	73	0.73	11.2	2	3.7	2.2	0.0046	35	51	63
100L-6	1.8	3.9	2.6	1135	77	0.75	15.1	2.5	4.9	3	0.0095	46	54	66
112M-6	2.6	5.4	3.6	1140	81	0.75	21.8	2.7	5.6	3.1	0.017	59	58	70
132S-6	3.6	7	4.7	1160	82.6	0.78	29.6	2.7	6.3	3.1	0.031	100	61	74
132M1-6	4.8	9.1	6.1	1150	93.6	0.79	40	2.6	6	3	0.037	104	61	74
132M2-6	6.6	12.1	8.1	1150	84.6	0.81	55	2.6	6.4	3	0.043	112	61	74
160M-6	8.6	14.7	9.8	1150	86.1	0.85	71	2.5	6.8	3.3	0.087	170	63	76
160L-6	12.6	21	14	1160	87.5	0.86	104	2.5	6.7	3.2	0.12	190	63	76
180L-6	18	30	20.1	1160	89.1	0.84	148	2.4	6.9	3.2	0.19	215	63	76
200L1-6	21.3	35.5	23.5	1170	89.7	0.84	174	1.9	6.3	2.7	0.28	270	63	77
200L2-6	26	42.5	28.5	1165	90.4	0.85	213	2.2	6.8	3	0.31	280	63	77
225M-6	35	58	38.5	1170	90.9	0.84	286	2.8	6.6	2.5	0.69	404	67	81
250M-6	44	72	48	1175	91.4	0.84	358	2.8	6.6	2.6	1.03	570	68	82
280S-6	52	85	57	1180	92.4	0.83	421	2.8	5.8	2.4	1.35	720	70	84
280M-6	64	106	71	1180	92.5	0.82	518	2.7	5.8	2.3	1.7	770	70	84
315S-6	87	135	90	1190	93	0.87	698	2.6	6.4	2.4	4.3	995	75	90
315M-6	105	161	107	1190	93.3	0.88	842	2.6	6.5	2.4	5	1050	75	90
315L1-6	121	184	123	1190	93.6	0.88	971	2.8	6.9	2.6	6	1145	75	90
315L2-6	145	220	147	1190	93.8	0.88	1164	2.8	7.1	2.6	7.3	1265	75	90
315L3-6	176	265	177	1190	94.3	0.88	1421	2.7	7.2	2.6	8.3	1440	75	90
355M-6	220	330	220	1190	94.8	0.88	1766	1.9	7.1	2.8	11.3	1750	80	96
355L1-6	275	410 <sup>1)</sup>	275	1190	95.9	0.88	2207	1.9	7.1	2.8	13.8	1950	80	96
355L2-6	345	515 <sup>1)</sup>	340	1190	96	0.88	2769	1.8	7.3	2.7	17.6	2300	80	96
400M-6	390	570 <sup>1)</sup>	380	1193	96.6	0.89	3122	1.15	7	2.8	27	2850	84	100
400L-6	440	640 <sup>1)</sup>	430 <sup>1)</sup>	1193	96.6	0.89	3522	1.15	7.2	2.7	31	3230	84	100
450M-6	495	725 <sup>1)</sup>	480 <sup>1)</sup>	1194	96.6	0.89	3959	1.3	7.2	3	46	3500	84	100
450L-6	550	800 <sup>1)</sup>	535 <sup>1)</sup>	1194	97	0.89	4399	1.15	7.2	2.8	51	3800	84	100
500..	by request													

**Note:**

- 1) Two parallel supply lines are required
- 2) Type B3 with terminal compartment type EAR

The values are also valid for series BD..

# Inverter operation 60 Hz

Temperature class T4,  
ns = 1200 rpm, 2p = 6

83

40°C ambient temperature. winding heating within heat class F

Operation on	Mains		Inverter								
	Self-ventilation		Inverter				Forced ventilation				
Ventilation											
Torque trend	-	square decreasing	constant	constant	constant	constant	constant	constant	constant	constant	constant
Frequency	60 Hz	6-60 Hz	24-60 Hz	12-60 Hz	6-60 Hz	6-60 Hz	6-60 Hz	6-60 Hz	6-60 Hz	6-60 Hz <sup>1)</sup>	6-60 Hz <sup>1)</sup>
Control range	-	1:10	1:2.5	1:5	1:10	1:10	1:10	1:10	1:10	1:10	1:10
Speed range	-	120-1200 rpm	480-1200 rpm	240-1200 rpm	120-1200 rpm	120-1200 rpm	120-1200 rpm	120-1200 rpm	120-1200 rpm	120-1200 rpm	120-1200 rpm
Power/torque CD..	P <sub>2</sub> [kW]	P <sub>U</sub> [kW] 60 Hz	M <sub>U</sub> [Nm]	P <sub>U</sub> [kW] 60 Hz	M <sub>U</sub> [Nm]	P <sub>U</sub> [kW] 60 Hz	M <sub>U</sub> [Nm]	P <sub>U</sub> [kW] 60 Hz	M <sub>U</sub> [Nm]	P <sub>U</sub> [kW] 60 Hz	M <sub>U</sub> [Nm]
71M2-6	0.3	0.3	2.6	0.26	2.2	0.22	1.86	0.19	1.59	-	-
80M1-6	0.42	0.42	3.6	0.37	3.15	0.31	2.6	0.25	2.1	-	-
80M2-6	0.64	0.64	5.5	0.58	4.95	0.47	3.95	0.38	3.15	-	-
90S-6	0.9	0.9	7.9	0.78	6.7	0.66	5.6	0.5	4.2	-	-
90L-6	1.3	1.3	11.2	1.06	9	0.95	8	0.71	5.9	-	-
100L-6	1.8	1.8	15.1	1.7	14.3	1.3	10.8	1.1	9.1	-	-
112M-6	2.6	2.6	22	2.4	20	2	16.6	1.5	12.3	-	-
132S1-6	3.6	3.6	29.5	3.2	26	2.6	21	2.2	17.9	3.6	29.5
132M1-6	4.8	4.8	40	4.2	34.5	3.6	29.5	3	24.5	4.8	40
132M2-6	6.6	6.6	55	5.8	48	4.8	39.5	4	32.5	6.6	55
160M-6	8.6	8.6	71	8	66	6.9	57	5.7	46.5	8.6	71
160L-6	12.6	12.6	104	11.5	94	10.3	84	8.6	70	12.6	104
180L-6	18	18	148	16	131	14	114	12	98	18	148
200L1-6	21.3	20 <sup>2)</sup>	163	18	146	16	130	14	113	20	163
200L2-6	26	24 <sup>2)</sup>	196	22	180	20	163	18	146	24	196
225M-6	35	32 <sup>2)</sup>	261	29	236	27	219	25	203	32	261
250M-6	44	39 <sup>2)</sup>	316	37	300	34	275	31	250	39	316
280S-6	52	46 <sup>2)</sup>	372	43	357	40	322	37	298	46	372
280M-6	64	55 <sup>2)</sup>	444	52	420	50	403	48	387	55	444
315S-6	87	75 <sup>2)</sup>	601	72	577	67	537	65	521	75	601
315M-6	105	91 <sup>2)</sup>	729	85	681	82	657	79	633	91	729
315L1-6	121	105 <sup>2)</sup>	842	99	793	97	777	94	753	105	842
315L2-6	145	126	1010	121	970	115	921	110	881	126	1010
315L3-6	176	154	1235	149	1194	141	1130	132	1057	154	1235
355M-6	220	187	1499	182	1458	176	1410	165	1321	187	1499
355L1-6	275	237	1900	226	1811	220	1763	209	1674	237	1900
355L2-6	345	296	2373	285	2284	274	2195	257	2058	296	2373
400M-6	390	335	2679	324	2591	313	2503	291	2326	335	2679
400L-6	440	380	3039	369	2951	352	2814	330	2638	380	3039
450M-6	495	429	3429	413	3301	396	3164	374	2988	429	3429
450L-6	550	479	3829	457	3652	440	3516	413	3299	479	3829

## Notes

<sup>1)</sup> Higher frequencies by request.

<sup>2)</sup> For inverter operation with output filter and practically sinusoidal output voltage. or clock frequency  $\geq 4$  kHz. output like P<sub>2</sub>.

Output during operation at the inverter (guide values). torque curves page 61

Overload protection via temperature sensor

# IE1 Mains operation 60 Hz

Temperature class T4,  
ns = 900 rpm, 2p = 8

84

Size	Output P <sub>2</sub> [kW]	Rated current at		Speed n [rpm]	Efficiency η [%]	Power factor cos φ	Torque M [Nm]	Starting torque M <sub>A</sub> / M <sub>N</sub>	Starting current I <sub>A</sub> / I <sub>N</sub>	Break down torque M <sub>K</sub> / M <sub>N</sub>	Mass moment of inertia J [kgm <sup>2</sup> ]	Weight <sup>2)</sup> m [kg]	Noise values with radial fan		
		460 V I [A]	690 V I [A]										L <sub>P</sub> [dB(A)]	L <sub>W</sub> [dB(A)]	
<b>CD..</b>	<b>Efficiency according to manufacturer's standard</b>														
<b>71M2-8</b>	0.14	0.54	0.36	815	49.5	0.65	1.64	1.9	2.6	2.4	0.0012	17	45	57	
<b>80M1-8</b>	0.21	0.75	0.50	830	54	0.65	2.4	2.2	3.2	2.6	0.0019	24	46	58	
<b>80M2-8</b>	0.3	1.01	0.67	830	58.5	0.64	3.45	2.2	3.2	2.5	0.0025	25	46	58	
<b>90S-8</b>	0.44	1.41	0.94	850	60	0.65	4.9	1.8	3	2.2	0.0033	31	50	62	
<b>90L-8</b>	0.64	1.96	1.31	835	63	0.65	7.3	1.8	3.1	2.2	0.0046	35	50	62	
<b>100L1-8</b>	0.9	2.55	1.70	850	67	0.66	10.1	2.4	4	2.6	0.008	44	53	65	
<b>100L2-8</b>	1.3	3.25	2.15	835	69	0.73	14.9	2	3.8	2.4	0.0095	46	53	65	
<b>112M-8</b>	1.8	4.45	3.0	850	76	0.67	20.2	2.2	4.6	2.8	0.017	59	57	69	
<b>132S-8</b>	2.6	5.4	3.6	835	77	0.79	29.7	2	4.1	2.3	0.029	97	58	71	
<b>132M-8</b>	3.6	7.3	4.85	845	80.5	0.77	41	2.4	4.6	2.7	0.036	113	58	71	
<b>160M1-8</b>	4.6	8.8	5.9	860	83.8	0.78	51	1.8	4.6	2.3	0.071	157	59	72	
<b>160M2-8</b>	6.5	12.5	8.3	865	84.7	0.77	72	2.1	5.4	2.8	0.105	170	59	72	
<b>160L-8</b>	9	17.2	11.5	865	85.2	0.77	99	2.2	5.6	2.9	0.136	190	59	72	
<b>180L-8</b>	13.2	24	16.1	870	87.1	0.79	145	2.4	6.4	3	0.22	215	61	74	
<b>200L-8</b>	18	32	21.5	875	88.5	0.80	196	2.4	6.9	3.2	0.4	280	61	75	
<b>225S-8</b>	22	39.5	26	875	89	0.79	242	2.2	6.3	3	0.56	372	62	76	
<b>225M-8</b>	26	46	31	875	89.5	0.79	284	2.2	6.6	3	0.69	404	62	76	
<b>250M-8</b>	36	61	41	880	90.1	0.82	391	2	6.8	3	1.2	550	63	77	
<b>280S-8</b>	44	74	49.5	880	91.1	0.82	478	2.1	6.2	2.8	1.9	740	66	80	
<b>280M-8</b>	52	87	58	880	91.3	0.82	564	2	6.3	2.6	2.3	800	66	80	
<b>315S-8</b>	61	100	67	885	91.8	0.83	658	2.7	6	2.5	4.3	995	74	89	
<b>315M-8</b>	87	142	95	885	92.6	0.83	939	2.8	6.3	2.6	5	1050	74	89	
<b>315L1-8</b>	105	171	114	885	92.8	0.83	1133	2.9	6.6	2.7	6	1145	74	89	
<b>315L2-8</b>	121	199	133	885	93	0.82	1306	3.1	7.2	2.8	7.3	1265	74	89	
<b>315L3-8</b>	145	240	159	885	93.1	0.82	1574	2.9	6.6	2.7	8.3	1440	74	89	
<b>355M-8</b>	176	280	187	890	95.1	0.83	1889	2	6.5	2.5	11.4	1750	76	92	
<b>355L1-8</b>	220	350	235	895	95.6	0.82	2347	1.8	7	2.5	13.9	1950	76	92	
<b>355L2-8</b>	275	440 <sup>1)</sup>	295	895	95.6	0.82	2934	1.5	6.5	2.5	17.7	2300	76	92	
<b>400M-8</b>	345	540 <sup>1)</sup>	360	895	96.2	0.83	3681	1.3	6.5	2.5	30	3100	79	95	
<b>400L-8</b>	390	610 <sup>1)</sup>	410 <sup>1)</sup>	895	96.3	0.83	4161	1.05	6.4	2.3	34	3440	79	95	
<b>450M-8</b>	440	680 <sup>1)</sup>	455 <sup>1)</sup>	895	96.6	0.84	4695	1.05	6.4	2.3	51	3750	80	96	
<b>450L-8</b>	495	765 <sup>1)</sup>	510 <sup>1)</sup>	895	96.7	0.84	5282	1.05	6.4	2.3	57	4050	80	96	
<b>500..</b>	by request														

**Note:**

- 1) Two parallel supply lines are required
- 2) Type B3 with terminal compartment type EAR

The values are also valid for series BD..

# Inverter operation 60 Hz

Temperature class T4,  
ns = 900 rpm, 2p = 8

85

40°C ambient temperature. winding heating within heat class F

Operation on	Mains		Inverter								
	Self-ventilation		Forced ventilation								
Ventilation											
Torque trend	-	square decreasing	constant	constant	constant	constant	constant	constant	constant	constant	constant
Frequency	60 Hz	6-60 Hz	24-60 Hz	12-60 Hz	6-60 Hz	6-60 Hz	6-60 Hz	6-60 Hz	6-60 Hz	6-60 Hz <sup>1)</sup>	6-60 Hz <sup>1)</sup>
Control range	-	1:10	1:2.5	1:5	1:10	1:10	1:10	1:10	1:10	1:10	1:10
Speed range	-	90-900 rpm	360-900 rpm	180-900 rpm	90-900 rpm	90-900 rpm	90-900 rpm	90-900 rpm	90-900 rpm	90-900 rpm	90-900 rpm
Power/torque CD..	P <sub>2</sub> [kW]	P <sub>U</sub> [kW] 60 Hz	M <sub>U</sub> [Nm]	P <sub>U</sub> [kW] 60 Hz	M <sub>U</sub> [Nm]	P <sub>U</sub> [kW] 60 Hz	M <sub>U</sub> [Nm]	P <sub>U</sub> [kW] 60 Hz	M <sub>U</sub> [Nm]	P <sub>U</sub> [kW] 60 Hz	M <sub>U</sub> [Nm]
71M2-8	0.14	0.14	1.64	0.13	1.51	0.12	1.39	0.09	1.02	-	-
80M1-8	0.21	0.21	2.4	0.19	2.15	0.15	1.69	0.13	1.45	-	-
80M2-8	0.3	0.3	3.45	0.26	2.95	0.22	2.5	0.19	2.1	-	-
90S-8	0.44	0.44	4.95	0.39	4.35	0.32	3.55	0.26	2.85	-	-
90L-8	0.64	0.64	7.3	0.58	6.6	0.47	5.3	0.38	4.2	-	-
100L1-8	0.9	0.9	10.1	0.8	8.9	0.7	7.8	0.5	5.5	-	-
100L2-8	1.3	1.3	14.9	1.1	12.4	0.9	10.1	0.7	7.7	-	-
112M-8	1.8	1.8	20	1.7	19	1.3	14.4	1.1	12.1	-	-
132S-8	2.6	2.6	29.5	2.4	27.5	2	25.5	1.5	16.6	2.6	29.5
132M-8	3.6	3.6	40.5	3.2	36	2.6	29	2.2	24.5	3.6	40.5
160M1-8	4.6	4.6	51	4	44	3.5	38.5	2.9	31.5	4.6	51
160M2-8	6.5	6.5	72	5.7	63	4.7	51	3.6	42.5	6.5	72
160L-8	9	9	99	8.4	92	6.6	72	5.4	59	9	99
180L-8	13.2	13.2	145	12	131	9.6	104	8.4	91	13.2	145
200L-8	18	18	196	16	174	13	141	12	130	18	196
225S-8	22	22	242	19	207	17	184	14	151	22	242
225M-8	26	26	284	22	239	20	217	18	195	26	284
250M-8	36	32 <sup>2)</sup>	346	30	324	28	302	25	269	32	346
280S-8	44	39 <sup>2)</sup>	422	37	400	34	367	31	334	39	422
280M-8	52	46 <sup>2)</sup>	498	43	465	40	432	37	399	46	498
315S-8	61	453 <sup>2)</sup>	571	50	538	48	516	45	483	53	571
315M-8	87	75 <sup>2)</sup>	807	72	775	67	720	65	698	75	807
315L1-8	105	91 <sup>2)</sup>	980	85	914	82	882	79	849	91	980
315L2-8	121	105 <sup>2)</sup>	1131	99	1065	97	1043	94	1011	105	1131
315L3-8	145	126	1363	121	1308	115	1242	110	1187	126	1363
355M-8	176	154	1650	149	1596	141	1510	132	1412	154	1650
355L1-8	220	187	1994	182	1940	176	1876	165	1758	187	1994
355L2-8	275	237	2527	226	2409	220	2345	209	2227	237	2527
400M-8	345	296	3156	285	3038	274	2920	257	2738	296	3156
400L-8	390	335	3572	324	3454	313	3336	291	3101	335	3572
450M-8	440	380	4052	369	3934	352	3752	330	3516	380	4052
450L-8	495	429	4574	413	4403	396	4221	374	3985	429	4574

## Notes

<sup>1)</sup> Higher frequencies by request.

<sup>2)</sup> For inverter operation with output filter and practically sinusoidal output voltage. or clock frequency  $\geq 4$  kHz. output like P<sub>2</sub>.

Output during operation at the inverter (guide values) torque curves page 61

Overload protection via temperature sensor

# IE2

## Mains operation 50 Hz

Temperature class T4,  
ns = 3000 rpm, 2p = 2

86

Size	Output	Rated current at		Speed	Efficiency	Power factor	Torque	Starting torque	Starting current	Breakdown torque	Mass moment of inertia	Weight <sup>2)</sup>	Noise values with radial fan		Noise values with axial fan	
		400 V	500 V										L <sub>P</sub>	L <sub>W</sub>	L <sub>P</sub>	L <sub>W</sub>
CD...Y2	P <sub>2</sub> [kW]	I [A]	I [A]	n [rpm]	η [%]	cos φ	M [Nm]	M <sub>A</sub> / M <sub>N</sub>	I <sub>A</sub> / I <sub>N</sub>	M <sub>K</sub> / M <sub>N</sub>	J [kgm <sup>2</sup> ]	m [kg]	L <sub>P</sub> [dB(A)]	L <sub>W</sub> [dB(A)]	L <sub>P</sub> [dB(A)]	L <sub>W</sub> [dB(A)]
<b>IE2 Efficiency according to IEC 60034-30</b>																
63M1-2	0.18	0.47	0.38	2835	66	0.83	0.61	3.2	6	4.7	0.00028	16	49	61	-	-
63M2-2	0.25	0.62	0.50	2825	70	0.83	0.85	3.1	5.8	4.5	0.00028	16	49	61	-	-
71M1-2	0.37	0.84	0.67	2825	73	0.87	1.25	2.6	5.7	3.4	0.00058	24	51	63	-	-
71M2-2	0.55	1.19	0.95	2830	77	0.87	1.86	2.7	6.1	3.6	0.00080	25	51	63	-	-
80M1-2	0.75	1.58	1.26	2890	79	0.87	2.48	3	6.6	3.6	0.0013	31	55	67	-	-
80M2-2	1.1	2.25	1.80	2885	81.1	0.87	3.64	3.2	7.1	3.5	0.0018	35	55	67	-	-
90S-2	1.5	3	2.4	2895	82.7	0.88	4.95	3	7.1	3.5	0.0029	45	60	72	-	-
90L-2	2.2	4.25	3.4	2900	84.5	0.88	7.2	3	7.3	3.6	0.0039	48	60	72	-	-
100L-2	3	5.7	4.6	2910	85.8	0.88	9.8	2.5	6.9	2.9	0.0051	53	63	75	-	-
112M-2	4	7.6	6.1	2930	86.9	0.87	13	2.8	6.9	3.6	0.0089	95	63	76	55	67
132S1-2	5.5	10.1	8.1	2925	88.1	0.89	18	2.5	7	3.3	0.0125	103	63	76	55	68
132S2-2	7.5	13.7	10.9	2930	89.1	0.89	24.4	2.7	7.1	3.5	0.0177	115	63	76	55	68
160M1-2	11	20	16.2	2940	90.3	0.87	35.7	3	7.3	3.6	0.032	163	66	79	56	69
160M2-2	15	26.5	21	2940	91.1	0.9	48.7	2.8	7.2	3.2	0.043	173	66	79	56	69
160L-2	18.5	32	25.5	2940	91.6	0.91	60	2.7	7.2	3.1	0.052	188	66	79	56	69
180M-2	22	38	30.5	2945	92	0.91	71	2.6	7.5	3.2	0.075	196	69	82	58	71
200L1-2	30	52	41.5	2955	92.7	0.9	97	2.7	7.5	3.1	0.13	254	71	85	60	74
200L2-2	37	64	51	2955	93.1	0.9	120	2.8	7.6	3.2	0.16	278	71	85	60	74
225M-2	45	77	62	2960	93.4	0.9	145	2.7	7.3	3	0.24	400	72	86	60	74
250M-2	55	96	77	2970	93.8	0.88	177	2.8	7.5	3.1	0.4	545	75	89	64	78
280S-2	75	131	104	2970	94.2	0.88	241	2.3	7.1	2.8	0.65	700	76	90	66	80
280M-2	90	158	126	2970	94.5	0.87	289	2.4	7.4	2.9	0.78	762	76	90	66	80
315S-2	110	188	150	2975	94.8	0.89	353	2.2	7.1	2.6	1.4	960	76	91	66	81
315M-2	132	225	180	2975	95	0.9	424	2.1	6.8	2.5	1.6	1025	76	91	66	81
315L1-2	160	270	215	2975	95.2	0.9	514	2.4	7.4	2.7	1.7	1065	76	91	66	81
315L2-2	200	335	270	2980	95.4	0.9	614	2.3	6.9	2.6	2.2	1270	76	91	66	81
315L3-2	250	410 <sup>1)</sup>	325	2980	96	0.92	801	1.7	7.2	2.7	2.8	1420	76	91	66	81
355L1-2	315	510 <sup>1)</sup>	410 <sup>1)</sup>	2980	96.6	0.92	1009	1.5	6.7	2.8	4.5	1900	81	97	68	84
355L2-2	355	570 <sup>1)</sup>	455 <sup>1)</sup>	2985	96.8	0.93	1136	1.4	6.9	2.7	5	2050	81	97	68	84
355L3-2	400	640 <sup>1)</sup>	515 <sup>1)</sup>	2985	96.8	0.93	1280	1.3	7	2.8	5.5	2350	81	97	68	84
400L-2	450	710 <sup>1)</sup>	570 <sup>1)</sup>	2990	97	0.94	1437	1.1	7.2	2.8	8.5	2910	81	97	-	-

**Note:**

- 1) Two parallel supply lines are required
- 2) Type B3 with terminal compartment type EAR

The values are also valid for series BD..

# Inverter operation 50 Hz

Temperature class T4,  
ns = 3000 rpm, 2p = 2

87

40°C ambient temperature. winding heating within heat class F

Operation on	Inverter													
	Mains	Self-ventilation										Forced ventilation		
Ventilation														
Torque trend	-	square decreasing	constant	constant	constant	constant	constant	constant	constant	constant	constant	constant	constant	
Frequency	50 Hz	5-50 Hz	20-50 Hz	10-50 Hz	5-50 Hz	50-87 Hz <sup>1)</sup>	5-87 Hz <sup>1)</sup>							
Control range	-	1:10	1:2.5	1:5	1:10									
Speed range	-	300-3000 rpm	1200-3000 rpm	600-3000 rpm	300-3000 rpm	3000-5220 rpm	300-5220 rpm							
Power/torque CD...Y2	P <sub>2</sub> [kW]	P <sub>U</sub> [kW] 50 Hz	M <sub>U</sub> [Nm]	P <sub>U</sub> [kW] 50 Hz	M <sub>U</sub> [Nm]	P <sub>U</sub> [kW] 50 Hz	M <sub>U</sub> [Nm]	P <sub>U</sub> [kW] 50 Hz	M <sub>U</sub> [Nm]	P <sub>U</sub> [kW] 87 Hz	M <sub>U</sub> [Nm]	P <sub>U</sub> [kW] 50 Hz	P <sub>U</sub> [kW] 87 Hz	
	63M1-2	0.18	0.18	0.59	0.16	0.52	0.14	0.46	0.12	0.39	0.25	0.47	-	-
63M2-2	0.25	0.25	0.83	0.22	0.73	0.19	0.63	0.15	0.49	0.37	0.7	-	-	
71M1-2	0.37	0.37	1.25	0.35	1.2	0.3	1	0.22	0.74	0.55	1	-	-	
71M2-2	0.55	0.55	1.9	0.52	1.8	0.45	1.5	0.33	1.1	0.8	1.5	-	-	
80M1-2	0.75	0.75	2.57	0.7	2.4	0.6	2	0.5	1.7	1.1	2	-	-	
80M2-2	1.1	1.1	3.73	1	3.4	0.9	3	0.75	2.5	1.6	2.9	-	-	
90S-2	1.5	1.5	5	1.4	4.7	1.2	4	1	3.3	2.2	4	-	-	
90L-2	2.2	2.2	7.4	2	6.7	1.7	5.7	1.4	4.7	3.3	6	-	-	
100L-2	3	3	10.1	2.7	8.9	2.2	7.2	1.8	5.9	4.5	8.2	-	-	
112M-2	4	4	13.3	3.7	12	3.2	11	2.5	8.2	6	11	-	-	
132S1-2	5.5	5.5	18.2	5	16	4.5	15	3.7	12	8	15	5.5	8	
132S2-2	7.5	7.5	24.6	7	23	6	20	5	16	11	20	7.5	10.5	
160M1-2	11	11	36	10	32	9	29	7.5	24	16	29	11	15	
160M2-2	15	14.5 <sup>2)</sup>	47	13	42	12	39	10	32	21	38	14.5	20	
160L-2	18.5	17.5 <sup>2)</sup>	57	16	52	15	49	12.5	41	26	48	17.5	25	
180M-2	22	21 <sup>2)</sup>	68	20	65	18	58	15	49	30	55	21	29	
200L1-2	30	28 <sup>2)</sup>	90	27	87	24	77	22	71	40	73	28	38	
200L2-2	37	32 <sup>2)</sup>	103	31	100	28	90	27	87	49	90	32	45	
225M-2	45	38 <sup>2)</sup>	123	37	119	34	110	32	103	60	110	38	55	
Frequency											50-60 Hz <sup>1)</sup>		5-60 Hz <sup>1)</sup>	
Speed range											3000-3600 rpm		300-3600 rpm	
250M-2	55	47 <sup>2)</sup>	151	45	145	43	138	41	132	47	126	47	47	
280S-2	75	62 <sup>2)</sup>	199	60	193	58	186	55	177	62	166	62	62	
280M-2	90	75 <sup>2)</sup>	241	73	234	70	225	67	215	75	201	75	75	
315S-2	110	95 <sup>2)</sup>	304	90	288	88	282	85	272	95	258	95	95	
315M-2	132	115	369	110	353	105	336	100	320	115	307	115	115	
315L1-2	160	140	449	135	433	128	410	120	385	140	374	140	140	
315L2-2	200	175	560	165	528	160	512	150	480	175	467	175	175	
315L3-2	250	215	688	205	656	200	640	185	592	215	574	215	215	
355L1-2	315	270	865	260	832	250	800	235	752	270	813	270	270	
355L2-2	355	305	976	295	944	285	912	265	848	305	918	305	305	
355L3-2	400	345	1104	335	1072	320	1024	300	960	345	1038	345	345	
400L-2	450	390	1245	375	1197	360	1149	340	1085	390	201	390	390	

## Notes

<sup>1)</sup> Higher frequencies by request.

<sup>2)</sup> For inverter operation with output filter and practically sinusoidal output voltage, or clock frequency  $\geq 4$  kHz, output like P<sub>2</sub>.

Output during operation at the inverter (guide values), torque curves page 58

Overload protection via temperature sensor

ATTENTION: From 01.07.2021, motors with efficiency classes IE1 and IE2 may only be supplied to the EU area as replacement motors for identical ATB motors that are already in operation.

# IE2

## Mains operation 50 Hz

Temperature class T4,  
ns = 1500 rpm, 2p = 4

88

Size	Output P <sub>2</sub> [kW]	Rated current at		Speed n [rpm]	Efficiency η [%]	Power factor cos φ	Torque M [Nm]	Starting torque M <sub>A</sub> / M <sub>N</sub>	Starting current I <sub>A</sub> / I <sub>N</sub>	Break down torque M <sub>K</sub> / M <sub>N</sub>	Mass moment of inertia J [kgm <sup>2</sup> ]	Weight <sup>2)</sup> m [kg]	Noise values with radial fan		Noise values with axial fan		
		400 V I [A]	500 V I [A]										L <sub>P</sub> [dB(A)]	L <sub>W</sub> [dB(A)]	L <sub>P</sub> [dB(A)]	L <sub>W</sub> [dB(A)]	
<b>IE2 Efficiency according to IEC 60034-30</b>																	
CD...Y2																	
63M1-4	0.12	0.37	0.30	1430	67	0.69	0.80	3.4	5.3	3.7	0.00046	16	44	56	-	-	
63M2-4	0.18	0.52	0.42	1425	70	0.71	1.21	2.8	5.2	3.4	0.00063	17	44	56	-	-	
71M1-4	0.25	0.69	0.55	1445	72.5	0.72	1.65	3.1	5.7	3.7	0.0092	24	45	57	-	-	
71M2-4	0.37	0.98	0.79	1435	76.5	0.71	2.46	3.6	6.3	3.9	0.0013	25	45	57	-	-	
80M1-4	0.55	1.26	1.01	1440	79.5	0.79	3.65	2.9	6.8	3.5	0.0021	31	46	58	-	-	
80M2-4	0.75	1.71	1.37	1445	81	0.78	5	3.2	6.8	4.2	0.0029	35	46	58	-	-	
90S-4	1.1	2.4	1.92	1455	82.7	0.8	7.2	2.4	6.8	3.1	0.0046	44	49	61	-	-	
90L-4	1.5	3.2	2.55	1450	84	0.81	9.9	2.5	6.9	3.2	0.0056	46	49	61	-	-	
100L1-4	2.2	4.4	3.55	1450	85.5	0.84	14.5	2.9	7.3	3.3	0.011	59	52	64	-	-	
100L2-4	3	6.0	4.75	1450	86.6	0.84	18.8	3.1	7.4	3.6	0.011	59	52	64	-	-	
112M-4	4	7.9	6.4	1460	87.6	0.83	26.2	3	7.2	3.4	0.022	100	54	66	-	-	
132S-4	5.5	10.5	8.4	1460	88.6	0.85	36	3.2	7.1	3.5	0.03	113	57	70	55	68	
132M-4	7.5	14.1	11.3	1460	89.5	0.86	49	3.1	7.4	3.3	0.041	125	57	70	55	68	
160M-4	11	20.5	16.5	1470	90.6	0.85	71	2.8	7.1	3.1	0.079	184	62	75	59	69	
160L-4	15	28.5	23	1470	91.3	0.83	97	3	7.4	3.3	0.083	187	62	75	59	69	
180M-4	18.5	35	28	1470	91.9	0.83	120	3.3	7.4	3.4	0.155	217	60	73	57	70	
180L-4	22	41.5	33	1470	92.3	0.81	143	3.2	7.3	3.4	0.164	225	60	73	57	70	
200L-4	30	55	44	1470	92.9	0.85	195	3.1	7.6	3.3	0.25	274	61	75	58	72	
225S-4	37	67	54	1475	93.3	0.85	240	3	7.1	2.9	0.4	372	63	77	59	73	
225M-4	45	81	65	1475	93.6	0.86	291	3.1	7.2	3	0.48	402	63	77	59	73	
250M-4	55	96	77	1475	94	0.88	356	3.1	7.3	3	0.75	588	65	79	64	78	
280S-4	75	135	108	1480	94.5	0.85	484	3	7.4	2.8	1.25	740	68	82	66	80	
280M-4	90	161	129	1485	94.7	0.85	579	3.2	7.8	3	1.48	820	68	82	66	80	
315S-4	110	199	159	1485	94.9	0.84	707	2.7	6.9	2.7	2.2	1040	69	84	66	81	
315M-4	132	240	191	1485	95.1	0.84	849	2.7	7	2.7	2.7	1120	69	84	66	81	
315L1-4	160	290	230	1485	95.3	0.84	1026	2.8	7.4	2.8	3.1	1210	69	84	66	81	
315L2-4	200	355	285	1485	95.5	0.85	1286	2.6	6.9	2.6	3.9	1430	69	84	66	81	
315L3-4	250	430 <sup>1)</sup>	345	1490	96.2	0.87	1602	1.7	7.3	2.7	4.6	1565	69	84	66	81	
355L1-4	315	525 <sup>1)</sup>	420 <sup>1)</sup>	1490	96.3	0.90	2019	1.5	6.9	2.7	6.1	2050	72	88	68	84	
355L2-4	355	590 <sup>1)</sup>	470 <sup>1)</sup>	1490	96.6	0.90	2275	1.6	6.9	2.8	6.7	2200	72	88	68	84	
355L3-4	400	665 <sup>1)</sup>	530 <sup>1)</sup>	1490	97	0.90	2564	1.5	7	2.8	7.4	2430	72	88	68	84	
400M-4	450	735 <sup>1)</sup>	590 <sup>1)</sup>	1495	97	0.91	2875	1.1	7.3	2.7	18	2850	78	94	-	-	
400L-4	500	815 <sup>1)</sup>	655 <sup>1)</sup>	1495	97.1	0.91	3194	1.1	7.3	2.7	20	3230	78	94	-	-	
450M-4	560	915 <sup>1)</sup>	730 <sup>1)</sup>	1495	97.2	0.91	3577	1	6.8	2.7	26	3500	79	95	-	-	
450L-4	630	1025 <sup>1)</sup>	820 <sup>1)</sup>	1495	97.4	0.91	4024	1	6.8	2.7	31	3800	79	95	-	-	
500..	by request																

### Note

- 1) Two parallel supply lines are required
- 2) Type B3 with terminal compartment type EAR

The values are also valid for series BD..

# Inverter operation 50 Hz

Temperature class T4,  
ns = 1500 rpm, 2p = 4

89

40°C ambient temperature. winding heating within heat class F

Operation on	Mains		Inverter										Inverter	
Ventilation			Self-ventilation										Forced ventilation	
Torque trend	-		square decreasing	constant	constant	constant	constant	constant	constant	constant	constant	constant	constant	constant
Frequency	50 Hz	5-50 Hz	20-50 Hz		10-50 Hz		5-50 Hz		50-87 Hz <sup>1)</sup>		5-87 Hz <sup>1)</sup>			
Control range	-	1:10	1:2.5		1:5		1:10							
Speed range	-	150-1500 rpm	600-1500 rpm		300-1500 rpm		150-1500 rpm		1500-2610 rpm		150-2610 rpm			
Power/torque CD...Y2	P <sub>2</sub> [kW]	P <sub>U</sub> [kW] 50 Hz	M <sub>U</sub> [Nm]	P <sub>U</sub> [kW] 50 Hz	M <sub>U</sub> [Nm]	P <sub>U</sub> [kW] 50 Hz	M <sub>U</sub> [Nm]	P <sub>U</sub> [kW] 50 Hz	M <sub>U</sub> [Nm]	P <sub>U</sub> [kW] 87 Hz	M <sub>U</sub> [Nm]	P <sub>U</sub> [kW] 50 Hz	P <sub>U</sub> [kW] 87 Hz	
63M1-4	0.12	0.12	0.79	0.11	0.73	0.09	0.59	0.08	0.53	0.18	0.68	-	-	
63M2-4	0.18	0.18	1.2	0.16	1.08	0.14	0.94	0.11	0.79	0.25	0.96	-	-	
70M1-4	0.25	0.25	1.74	0.22	1.5	0.19	1.25	0.15	1	0.37	1.4	-	-	
71M2-4	0.37	0.37	2.56	0.33	2.2	0.28	1.9	0.22	1.5	0.55	2	-	-	
80M1-4	0.55	0.55	3.8	0.52	3.5	0.45	3	0.33	2.2	0.8	2.9	-	-	
80M2-4	0.75	0.75	5.1	0.7	4.8	0.6	4	0.5	3.3	1.1	4	-	-	
90S-4	1.1	1.1	7.5	1	6.7	0.9	6	0.75	5	1.6	5.9	-	-	
90L-4	1.5	1.5	10.2	1.4	9.5	1.2	8	1	6.7	2.2	8	-	-	
100L1-4	2.2	2.2	14.8	2	13	1.7	11	1.4	9.3	3.3	12	-	-	
100L2-4	3	3	20.2	2.8	19	2.2	15	1.8	12	4.5	16	-	-	
112M-4	4	4	26.6	3.6	24	3	20	2.5	16	6	22	-	-	
132S-4	5.5	5.5	36.5	5	33	4.4	29	3.7	24	8	29	5.5	8	
132M-4	7.5	7.5	50	7	46	6	39	5	33	11	40	7.5	10.5	
160M-4	11	11	72	10	65	9	58	7.5	49	16	59	11	15	
160L-4	15	15	98	13.5	88	12	78	10	65	21	79	15	20	
180M-4	18.5	18 <sup>2)</sup>	118	18	111	15	97	12.5	81	26	95	18	25	
180L-4	22	21 <sup>2)</sup>	137	20	130	18	117	15	97	30	110	21	29	
200L-4	30	28 <sup>2)</sup>	183	27	176	24	156	21	136	40	146	28	37	
225S-4	37	32 <sup>2)</sup>	208	31	201	29	188	26	168	49	179	32	45	
225M-4	45	38 <sup>2)</sup>	247	37	240	35	227	32	207	60	220	38	55	
250M-4	55	46 <sup>2)</sup>	298	45	291	43	278	41	265	70	256	46	65	
280S-4	75	62 <sup>2)</sup>	400	60	386	58	373	55	354	95	348	62	88	
280M-4	90	75 <sup>2)</sup>	482	73	470	70	450	66	424	110	402	75	105	
315S-4	110	95 <sup>2)</sup>	610	90	577	88	564	83	532	140	512	95	130	
315M-4	132	115	737	110	705	105	673	100	641	165	604	115	157	
315L1-4	160	140	897	135	865	128	820	120	769	200	732	140	190	
315L2-4	200	175	1122	165	1058	160	1026	150	961	250	915	175	240	
315L3-4	250	215	1378	205	1314	200	1282	185	1186	310	1134	215	305	
355L1-4	315	270	1731	260	1666	250	1602	235	1506	395	1445	270	385	
355L2-4	355	305	1955	295	1891	285	1827	265	1698	440	1610	305	425	
355L3-4	400	345	2209	335	2145	320	2048	300	1920	495	1820	345	480	
400M-4	450	390	2500	375	2405	360	2307	340	2179	560	2050	390	540	
400L-4	500	435	2778	415	2650	400	2553	380	2425	620	2274	435	600	
450M-4	560	485	3097	465	2969	450	2873	425	2713	695	2549	485	670	
450L-4	630	545	3480	525	3352	505	3224	475	3032	785	2879	545	755	

## Notes

<sup>1)</sup> Higher frequencies by request.

<sup>2)</sup> For inverter operation with output filter and practically sinusoidal output voltage. or clock frequency  $\geq 4$  kHz. output like P<sub>2</sub>.

Output during operation at the inverter (guide values). torque curves page 59

Overload protection via temperature sensor

ATTENTION: From 01.07.2021, motors with efficiency classes IE1 and IE2 may only be supplied to the EU area as replacement motors for identical ATB motors that are already in operation.

# IE2

## Mains operation 50 Hz

Temperature class T4,  
ns = 1000 rpm, 2p = 6

90

Size	Output P <sub>2</sub> [kW]	Rated current at		Speed n [rpm]	Efficiency η [%]	Power factor cos φ	Torque M [Nm]	Starting torque M <sub>A</sub> / M <sub>N</sub>	Starting current I <sub>A</sub> / I <sub>N</sub>	Break down torque M <sub>K</sub> / M <sub>N</sub>	Mass moment of inertia J [kgm <sup>2</sup> ]	Weight <sup>2)</sup>		Noise values with radial fan	
		400 V I [A]	500 V I [A]									m [kg]	L <sub>P</sub> [dB(A)]	L <sub>W</sub> [dB(A)]	
<b>IE2 Efficiency according to IEC60034-30</b>															
CD...Y2															
71M2-6	0.25	0.76	0.61	935	67.5	0.70	2.55	2.5	4.4	3.2	0.0025	25	44	56	
80M1-6	0.37	1.04	0.83	950	72.5	0.71	3.7	1.7	4.4	3	0.0033	31	44	56	
80M2-6	0.55	1.43	1.14	945	76	0.73	5.6	1.8	4.5	3.1	0.0046	35	44	56	
90S-6	0.75	2	1.60	955	77.4	0.70	7.5	2.7	5.5	3.1	0.0080	44	47	59	
90L-6	1.1	2.75	2.2	955	79.5	0.72	11	2.8	5.9	3.1	0.0095	46	47	59	
100L-6	1.5	3.75	3.0	965	81.1	0.71	14.8	3	6.8	3.3	0.017	59	50	62	
112M-6	2.2	4.9	3.9	965	83	0.78	21.8	2.6	6.8	3.1	0.031	100	53	65	
132S-6	3	6.9	5.5	970	84.4	0.74	29.5	3.2	7.1	3.7	0.031	100	56	69	
132M1-6	4	8.9	7.1	965	85.7	0.76	39.6	2.9	6.9	3.7	0.037	104	56	69	
132M2-6	5.5	11.7	9.4	965	87	0.78	54	2.9	7.2	3.7	0.048	117	56	69	
160M-6	7.5	14.6	11.7	970	88.1	0.84	74	2.8	7.5	3.8	0.12	190	58	71	
160L-6	11	22	17.5	975	89.5	0.81	108	3	7.6	3.9	0.12	190	58	71	
180L-6	15	29	23.5	975	90.4	0.82	147	2.7	7.4	3.8	0.19	215	58	71	
200L1-6	18.5	35.5	28.5	975	91	0.83	181	2.5	7	3.5	0.28	270	58	71	
200L2-6	22	41.5	33	975	91.5	0.84	215	2.2	6.9	3.2	0.31	280	58	72	
225M-6	30	57	45	985	92.3	0.83	291	3	6.9	2.7	0.69	404	58	72	
250M-6	37	69	56	985	92.7	0.83	359	3	6.8	2.7	1.03	570	58	76	
280S-6	45	85	68	985	93.5	0.82	436	2.8	6.6	2.4	1.35	720	62	77	
280M-6	55	105	84	985	93.6	0.81	533	2.8	6.5	2.4	1.7	770	62	77	
315S-6	75	131	105	990	94.1	0.88	723	3	7.2	2.7	4.3	995	65	79	
315M-6	90	156	125	990	94.4	0.88	868	3.2	7.7	2.8	5	1050	65	79	
315L1-6	110	191	152	990	94.7	0.88	1061	3.3	7.8	2.8	6	1145	69	84	
315L2-6	132	230	182	990	95	0.88	1273	3.2	7.7	2.8	7.3	1265	69	84	
315L3-6	160	275	220	990	95.2	0.88	1543	3.3	7.8	2.8	8.3	1440	69	84	
355M-6	200	345	275	990	95.5	0.87	1929	1.8	6.7	2.7	11.3	1750	74	90	
355L1-6	250	430 <sup>1)</sup>	345	990	95.9	0.88	2411	1.8	6.7	2.7	13.8	1950	74	90	
355L2-6	315	540 <sup>1)</sup>	430 <sup>1)</sup>	990	96	0.88	3039	1.7	6.9	2.6	17.6	2300	74	90	
400M-6	355	595 <sup>1)</sup>	475 <sup>1)</sup>	994	96.6	0.89	3411	1.1	6.6	2.7	27	2850	78	94	
400L-6	400	670 <sup>1)</sup>	535 <sup>1)</sup>	994	96.6	0.89	3843	1.1	6.8	2.6	31	3230	78	94	
450M-6	450	755 <sup>1)</sup>	605 <sup>1)</sup>	995	96.6	0.89	4319	1.2	6.8	2.8	46	3500	78	94	
450L-6	500	835 <sup>1)</sup>	670 <sup>1)</sup>	995	97	0.89	4799	1.1	6.8	2.7	51	3800	78	94	
500..	by request														

**Note:**

- 1) Two parallel supply lines are required
- 2) Type B3 with terminal compartment EAR

The values are also valid for series BD..

# Inverter operation 50 Hz

Temperature class T4,  
ns = 1000 rpm, 2p = 6

91

40°C ambient temperature. winding heating within heat class F

Operation on	Inverter												
	Mains	Self-ventilation										Inverter Forced ventilation	
Ventilation													
Torque trend	-	square decreasing	constant	constant	constant	constant	constant	constant	constant	constant	constant	constant	constant
Frequency	50 Hz	5-50 Hz	20-50 Hz	10-50 Hz	5-50 Hz	50-87 Hz <sup>1)</sup>	5-87 Hz <sup>1)</sup>						
Control range	-	1:10	1:2.5	1:5	1:10								
Speed range	-	100-1000 rpm	400-1000 rpm	200-1000 rpm	100-1000 rpm	1000-1740 rpm	100-1740 rpm						
Power/torque CD...Y2	P <sub>2</sub> [kW]	P <sub>U</sub> [kW] 50 Hz	M <sub>U</sub> [Nm]	P <sub>U</sub> [kW] 50 Hz	M <sub>U</sub> [Nm]	P <sub>U</sub> [kW] 50 Hz	M <sub>U</sub> [Nm]	P <sub>U</sub> [kW] 50 Hz	M <sub>U</sub> [Nm]	P <sub>U</sub> [kW] 87 Hz	M <sub>U</sub> [Nm]	P <sub>U</sub> [kW] 50 Hz	P <sub>U</sub> [kW] 87 Hz
71M2-6	0.25	0.25	2.6	0.22	2.2	0.18	1.8	0.16	1.6	0.37	2	-	-
80M1-6	0.37	0.37	3.8	0.33	3.4	0.27	2.7	0.22	2.2	0.55	3	-	-
80M2-6	0.55	0.55	5.7	0.5	5.1	0.4	4	0.33	3.3	0.8	4.4	-	-
90S-6	0.75	0.75	7.9	0.65	6.7	0.55	5.5	0.42	4.2	1.1	6	-	-
90L-6	1.1	1.1	11.4	0.9	9.2	0.8	8	0.6	6	1.6	8.8	-	-
100L-6	1.5	1.5	15.2	1.4	14	1.1	11	0.9	9	2.2	12	-	-
112M-6	2.2	2.2	22.1	2	20	1.7	17	1.3	13	3.3	18	-	-
132S1-6	3	3	29.7	2.7	27	2.2	22	1.8	18	4.5	25	3	4.2
132M1-6	4	4	40	3.5	35	3	30	2.5	25	6	33	4	5.5
132M2-6	5.5	5.5	55	4.8	48	4	40	3.3	33	8	44	5.5	7.6
160M-6	7.5	7.5	75	7	69	6	59	5	49	11	60	7.5	10.5
160L-6	11	11	109	10	98	9	88	7.5	73	16	88	11	15
180L-6	15	15	148	13	128	12	118	10	98	21	115	15	20
200L1-6	18.5	17.5 <sup>2)</sup>	171	16	157	14	137	12	118	26	143	17.5	24
200L2-6	22	20 <sup>2)</sup>	196	19	186	17	167	15	147	30	165	20	28
225M-6	30	27 <sup>2)</sup>	262	25	242	23	223	21	204	40	220	27	37
250M-6	37	33 <sup>2)</sup>	320	31	301	29	281	26	252	49	269	33	45
280S-6	45	40 <sup>2)</sup>	386	37	357	35	338	32	309	60	329	40	55
280M-6	55	47 <sup>2)</sup>	453	45	434	43	415	41	396	70	384	47	65
315S-6	75	65 <sup>2)</sup>	627	62	598	58	559	56	540	95	521	65	88
315M-6	90	78 <sup>2)</sup>	752	73	704	70	675	68	656	110	604	78	105
315L1-6	110	95 <sup>2)</sup>	916	90	868	88	849	85	820	140	768	95	130
315L2-6	132	115	1109	110	1061	105	1013	100	965	165	906	115	157
315L3-6	160	140	1351	135	1302	128	1235	120	1158	200	1098	140	190
355M-6	200	170	1640	165	1592	160	1543	150	1447	250	1372	170	240
355L1-6	250	215	2074	205	1978	200	1929	190	1833	310	1701	215	305
355L2-6	315	270	2605	260	2508	250	2412	235	2267	395	2168	270	385
400M-6	355	305	2942	295	2846	285	2749	265	2556	440	2115	305	425
400L-6	400	345	3328	335	3232	320	3087	300	2894	495	2717	345	480
450M-6	450	390	3762	375	3617	360	3473	340	3280	560	3074	390	540
450L-6	500	435	4196	415	4003	400	3859	375	3618	620	3404	435	600

## Notes

<sup>1)</sup> Higher frequencies by request.

<sup>2)</sup> For inverter operation with output filter and practically sinusoidal output voltage. or clock frequency  $\geq 4$  kHz. output like P<sub>2</sub>.

Output during operation at the inverter (guide values) torque curves page 59

Overload protection via temperature sensor

ATTENTION: From 01.07.2021, motors with efficiency classes IE1 and IE2 may only be supplied to the EU area as replacement motors for identical ATB motors that are already in operation.

# IE2

## Mains operation 50 Hz

Temperature class T4,  
n<sub>s</sub> = 750 rpm, 2p = 8

92

Size	Output P <sub>2</sub> [kW]	Rated current at		Speed n [rpm]	Efficiency η [%]	Power factor cos φ	Torque M [Nm]	Starting torque M <sub>A</sub> / M <sub>N</sub>	Starting current I <sub>A</sub> / I <sub>N</sub>	Breakdown torque M <sub>K</sub> / M <sub>N</sub>	Mass moment of inertia J [kgm <sup>2</sup> ]	Weight <sup>2)</sup> m [kg]	Noise values with radial fan		
		400 V I [A]	500 V I [A]										L <sub>p</sub> [dB(A)]	L <sub>w</sub> [dB(A)]	
<b>IE2 Efficiency according to IEC 60034-30</b>															
CD...Y2															
71M2-8	0.12	0.57	0.45	700	50	0.61	1.64	2.2	3.5	2.7	0.0025	25	41	53	
80M1-8	0.18	0.66	0.52	705	58	0.58	2.43	1.9	3.2	2.7	0.0033	31	42	54	
80M2-8	0.25	0.91	0.73	710	63	0.60	3.35	1.7	3.3	2.5	0.0046	35	42	54	
90S-8	0.37	1.30	1.04	715	68	0.64	4.95	1.7	4.4	3	0.008	44	46	58	
90L-8	0.55	1.85	1.48	715	71.5	0.64	7.3	1.8	4.5	3.1	0.0095	46	46	58	
100L1-8	0.75	2.3	1.83	720	74	0.64	9.9	2.3	5	2.9	0.008	44	49	61	
100L2-8	1.1	3.0	2.4	715	77.1	0.67	14.7	2.2	4.8	2.7	0.0095	46	49	61	
112M-8	1.5	3.6	2.85	705	79.6	0.77	20.3	2	4.9	2.6	0.017	59	52	64	
132S-8	2.2	5.4	4.3	710	81.6	0.72	29.6	2.8	6.3	3.2	0.029	97	53	66	
132M-8	3	7.2	5.8	715	83.1	0.72	40	2.7	6.3	3.1	0.036	113	53	66	
160M1-8	4	8.8	7	725	84.4	0.77	53	1.9	5.6	2.6	0.071	157	54	67	
160M2-8	5.5	12	9.6	725	85.7	0.76	72	2.3	6	3.1	0.105	170	54	67	
160L-8	7.5	16.8	13.5	725	86.6	0.74	99	2.4	6.5	3.2	0.136	190	54	67	
180L-8	11	23	18.5	725	88.2	0.78	145	2.6	6.9	3.3	0.22	215	56	69	
200L-8	15	32	25	730	89.1	0.77	196	2.4	7.1	3.3	0.4	280	56	70	
225S-8	18.5	38	31	735	89.6	0.78	240	2.3	7.1	3.4	0.56	372	57	71	
225M-8	22	45	36.0	735	90	0.78	286	2.4	7.2	3.5	0.69	404	57	71	
250M-8	30	60	47.5	735	90.8	0.8	390	2.5	7.1	3.4	1.2	550	58	72	
280S-8	37	71	57	735	91.2	0.82	481	2	6.5	2.9	1.9	740	61	75	
280M-8	45	86	69	740	91.7	0.82	581	2.2	6.7	2.9	2.3	800	61	75	
315S-8	55	104	83	740	92	0.83	710	2.7	6	2.5	4.3	995	68	83	
315M-8	75	141	112	740	92.8	0.83	968	2.8	6.3	2.6	5	1050	68	83	
315L1-8	90	168	135	740	93	0.83	1161	2.9	6.6	2.7	6	1145	68	83	
315L2-8	110	210	166	740	93.2	0.82	1420	2.9	6.8	2.7	7.3	1265	68	83	
315L3-8	132	250	199	740	93.4	0.82	1704	2.8	6.3	2.6	8.3	1440	68	83	
355M-8	160	290	235	745	95.3	0.83	2051	1.7	6.4	2.6	11.4	1750	70	86	
355L1-8	200	370	295	745	95.6	0.82	2564	1.6	6.6	2.6	13.9	1950	70	86	
355L2-8	250	460 <sup>1)</sup>	370	745	95.6	0.82	3205	1.4	6.1	2.6	17.7	2300	70	86	
400M-8	315	570 <sup>1)</sup>	455 <sup>1)</sup>	745	96.2	0.83	4038	1.2	6.2	2.7	30	3100	73	89	
400L-8	355	640 <sup>1)</sup>	515 <sup>1)</sup>	745	96.3	0.83	4551	1	6.1	2.6	34	3440	73	89	
450M-8	400	710 <sup>1)</sup>	570 <sup>1)</sup>	745	96.6	0.84	5128	1	6.1	2.8	51	3750	74	90	
450L-8	450	800 <sup>1)</sup>	640 <sup>1)</sup>	745	96.7	0.84	5768	1	6.1	2.8	57	4050	74	90	
500..	by request														

**Note:**

- 1) Two parallel supply lines are required
- 2) Type B3 with terminal compartment type EAR

The values are also valid for series BD..

ATTENTION: From 01.07.2021, motors with efficiency classes IE1 and IE2 may only be supplied to the EU area as replacement motors for identical ATB motors that are already in operation.

## Inverter operation 50 Hz

Temperature class T4,  
ns = 750 rpm, 2p = 8

93

40°C ambient temperature. winding heating within heat class F

Operation on	Mains		Inverter								Inverter		
			Self-ventilation								Forced ventilation		
Ventilation													
Torque trend	-	square decreasing	constant	constant	constant	constant	constant	constant	constant	constant	constant	constant	constant
Frequency	50 Hz	5-50 Hz	20-50 Hz	10-50 Hz	5-50 Hz	10-50 Hz	5-50 Hz	50-87 Hz <sup>1)</sup>	50-87 Hz <sup>1)</sup>	50-87 Hz <sup>1)</sup>	50-87 Hz <sup>1)</sup>	5-87 Hz <sup>1)</sup>	5-87 Hz <sup>1)</sup>
Control range	-	1:10	1:2.5	1:5	1:10	1:10	1:10	1:10	1:10	1:10	1:10	1:10	1:10
Speed range	-	100-1000 rpm	400-1000 rpm	200-1000 rpm	100-1000 rpm	100-1000 rpm	100-1000 rpm	1000-1740 rpm	1000-1740 rpm	1000-1740 rpm	1000-1740 rpm	100-1740 rpm	100-1740 rpm
Power/torque CD...Y2	P <sub>2</sub> [kW]	P <sub>U</sub> [kW] 50 Hz	M <sub>U</sub> [Nm]	P <sub>U</sub> [kW] 50 Hz	M <sub>U</sub> [Nm]	P <sub>U</sub> [kW] 50 Hz	M <sub>U</sub> [Nm]	P <sub>U</sub> [kW] 50 Hz	M <sub>U</sub> [Nm]	P <sub>U</sub> [kW] 87 Hz	M <sub>U</sub> [Nm]	P <sub>U</sub> [kW] 50 Hz	P <sub>U</sub> [kW] 87 Hz
71M2-8	0.12	0.12	1.7	0.11	1.5	0.1	1.4	0.08	1.1	0.18	1.3	-	-
80M1-8	0.18	0.18	2.5	0.16	2.2	0.13	1.7	0.11	1.5	0.25	1.8	-	-
80M2-8	0.25	0.25	3.5	0.22	3	0.18	2.4	0.16	2.2	0.37	2.7	-	-
90S-8	0.37	0.37	5.1	0.33	4.4	0.27	3.6	0.22	3	0.55	4	-	-
90L-8	0.55	0.55	7.6	0.5	6.7	0.4	5.4	0.33	4.4	0.8	5.9	-	-
100L1-8	0.75	0.75	10.1	0.65	8.7	0.55	7.4	0.42	5.6	1.1	8	-	-
100L2-8	1.1	1.1	15.1	0.9	12	0.8	11	0.6	8.1	1.6	12	-	-
112M-8	1.5	1.5	20.2	1.4	19	1.1	15	0.9	12	2.2	16	-	-
132S-8	2.2	2.2	30	2	27	1.7	23	1.3	17	3.3	24	2.2	3.1
132M-8	3	3	41	2.7	36	2.2	29	1.8	24	4.5	33	3	4.2
160M1-8	4	4	53	3.5	46	3	40	2.5	33	6	44	4	5.5
160M2-8	5.5	5.5	73	4.8	64	4	52	3.3	44	8	59	5.5	7.6
160L-8	7.5	7.5	99	7	92	5.5	72	4.5	59	11	80	7.5	10.5
180L-8	11	11	145	10	131	8	104	7	91	16	117	11	15
200L-8	15	15	196	13	170	11	143	10	130	21	154	15	20
225S-8	18.5	18.5	242	16	208	14	181	12	155	26	190	18.5	25
225M-8	22	22	288	19	245	17	219	15	194	30	220	22	29
250M-8	30	27 <sup>2)</sup>	348	25	323	23	297	21	271	40	293	27	37
280S-8	37	33 <sup>2)</sup>	426	31	400	29	374	26	336	49	359	33	45
280M-8	45	40 <sup>2)</sup>	516	37	478	35	452	32	413	60	439	40	55
315S-8	55	48 <sup>2)</sup>	619	45	581	43	555	41	529	70	512	48	65
315M-8	75	65 <sup>2)</sup>	839	62	800	58	749	56	723	95	695	65	88
315L1-8	90	78 <sup>2)</sup>	1007	73	942	70	903	68	878	110	805	78	105
315L2-8	110	95 <sup>2)</sup>	1226	90	1161	88	1136	85	1097	140	1025	95	130
315L3-8	132	115	1484	110	1420	105	1309	100	1247	165	1027	115	157
355M-8	160	140	1807	135	1743	128	1596	120	1496	200	1464	140	190
355L1-8	200	170	2194	165	2129	160	1994	150	1870	250	1830	170	240
355L2-8	250	215	2775	205	2646	200	2493	190	2368	310	2269	215	305
400M-8	315	270	3484	260	3355	250	3116	235	2929	395	2891	270	385
400L-8	355	305	3935	295	3807	285	3553	265	3303	440	3220	305	425
450M-8	400	345	4452	335	4323	320	3989	300	3740	495	3622	345	480
450L-8	450	390	5033	375	4839	360	4488	340	4239	560	4098	390	540

### Notes

<sup>1)</sup> Higher frequencies by request.

<sup>2)</sup> For inverter operation with output filter and practically sinusoidal output voltage, or clock frequency  $\geq 4$  kHz. output like P<sub>2</sub>.

Output during operation at the inverter (guide values) torque curves page 59

Overload protection via temperature sensor

# IE2

## Mains operation 60 Hz

Temperature class T4,  
ns = 3600 rpm, 2p = 2

94

Size	Output	Rated current at		Speed	Efficiency	Power factor	Torque	Starting torque	Starting current	Break down torque	Mass moment of inertia	Weight <sup>2)</sup>	Noise values with radial fan		Noise values with axial fan	
		460 V	690 V										L <sub>P</sub>	L <sub>W</sub>	L <sub>P</sub>	L <sub>W</sub>
	P <sub>2</sub>	I	I	n	η	cos φ	M	M <sub>A</sub> / M <sub>N</sub>	I <sub>A</sub> / I <sub>N</sub>	M <sub>K</sub> / M <sub>N</sub>	J	m	[dB(A)]	[dB(A)]	[dB(A)]	[dB(A)]
	[kW]	[A]	[A]	[rpm]	[%]		[Nm]				[kgm <sup>2</sup> ]	[kg]				
<b>IE2 Efficiency according to IEC 60034-30</b>																
CD...Y3																
63M1-2	0.18	0.39	0.26	3465	71.5	0.81	0.5	3.7	7	5.5	0.00028	16	53	65	-	-
63M2-2	0.25	0.52	0.35	3455	74.5	0.81	0.69	3.6	6.7	5.3	0.00028	16	53	65	-	-
71M1-2	0.37	0.73	0.49	3440	75.5	0.84	1.03	3	6.7	3.9	0.00058	24	56	68	-	-
71M2-2	0.55	1.03	0.67	3445	79.5	0.84	1.52	3.1	7.1	4.2	0.00080	25	56	68	-	-
80M1-2	0.75	1.4	0.94	3490	79.9	0.84	2.11	3.3	7.7	4.2	0.0013	31	60	72	-	-
80M2-2	1.1	1.96	1.31	3490	82.9	0.85	3.64	3.5	7.9	4.3	0.0018	35	60	72	-	-
90S-2	1.5	2.55	1.71	3505	84.3	0.87	4.1	3.4	8.5	3.8	0.0029	45	65	77	-	-
90L-2	2.2	3.65	2.45	3505	85.9	0.88	6	3.4	8.5	3.9	0.0039	48	65	77	-	-
100L-2	3	5	3.35	3520	85.8	0.87	8.1	2.9	8.2	3.4	0.0051	53	68	80	-	-
112M-2	4	6.6	4.4	3530	87.8	0.87	10.8	3.2	8.3	4	0.0089	95	68	80	-	-
132S1-2	5.5	8.8	5.9	3520	89.1	0.89	14.9	2.9	8.3	3.7	0.0125	103	68	81	60	73
132S2-2	7.5	11.8	7.9	3525	89.5	0.91	20.3	3.1	8.4	4	0.0177	115	68	81	60	73
160M1-2	11	18.2	12.1	3540	90.3	0.84	29.7	3.3	8.5	4	0.032	163	71	84	61	74
160M2-2	15	23.5	15.6	3545	90.4	0.89	40.5	3.6	8.5	4	0.043	173	71	84	61	74
160L-2	18.5	28	18.6	3545	91.3	0.91	49.8	3.3	8.4	3.9	0.052	188	71	84	61	74
180M-2	22	34.5	23	3560	91.5	0.88	59	3.2	8.6	3.8	0.075	196	75	88	64	77
200L1-2	30	45.5	30.5	3555	92	0.90	81	3.1	8.4	3.6	0.13	254	77	91	65	79
200L2-2	37	56	37	3560	92.6	0.90	99	3.3	8.6	3.8	0.16	278	77	91	65	79
225M-2	45	68	45	3555	93.5	0.89	121	3	8.4	3.3	0.24	400	78	92	66	80
250M-2	55	85	57	3575	93.7	0.87	147	3	8.5	3.3	0.4	545	81	95	70	84
280S-2	75	115	77	3570	93.9	0.87	201	2.7	8.2	3.1	0.65	700	82	96	72	86
280M-2	90	137	92	3570	94.6	0.87	241	2.9	8.4	3.4	0.78	762	82	96	72	86
315S-2	110	164	109	3575	94.8	0.89	294	2.7	8.2	3.1	1.4	960	82	96	73	88
315M-2	132	193	129	3575	95.2	0.90	353	2.9	8.5	3.2	1.6	1025	82	96	73	88
315L1-2	160	235	156	3580	95.4	0.90	427	2.8	8.6	3	1.9	1065	82	96	73	88
315L2-2	200	290	195	3580	95.5	0.90	533	2.6	8	3	2.2	1270	82	96	73	88
315L3-2	250	360	240	3580	95.6	0.91	667	2	8.4	3.1	2.8	1420	82	96	73	88
355L1-2	345	490 <sup>1)</sup>	325	3575	96.1	0.92	922	1.6	7.1	3	4.5	1900	87	103	75	91
355L2-2	390	545 <sup>1)</sup>	365	3580	96.3	0.93	1040	1.5	7.3	2.8	5	2050	87	103	75	91
355L3-2	440	615 <sup>1)</sup>	410 <sup>1)</sup>	3580	96.3	0.93	1174	1.4	7.4	2.8	5.5	2350	87	103	75	91
400L-2	495	685 <sup>1)</sup>	455 <sup>1)</sup>	3585	96.5	0.94	1319	1.15	7.6	3	8.5	2910	87	103	81	97

**Note:**

- 1) Two parallel supply lines are required
- 2) Type B3 with terminal compartment type EAR

The values are also valid for series BD..

# IE2 Mains operation 60 Hz

Temperature class T4,  
ns = 1800 rpm, 2p = 4

95

Size	Output	Rated current at		Speed	Efficiency	Power factor	Torque	Starting torque	Starting current	Break down torque	Mass moment of inertia	Weight <sup>2)</sup>	Noise values with radial fan		Noise values with axial fan	
		460 V	690 V										L <sub>P</sub>	L <sub>W</sub>	L <sub>P</sub>	L <sub>W</sub>
p	P <sub>2</sub> [kW]	I [A]	I [A]	n [rpm]	η [%]	cos φ	M [Nm]	M <sub>A</sub> / M <sub>N</sub>	I <sub>A</sub> / I <sub>N</sub>	M <sub>K</sub> / M <sub>N</sub>	J [kgm <sup>2</sup> ]	m [kg]	L <sub>P</sub> [dB(A)]	L <sub>W</sub> [dB(A)]	L <sub>P</sub> [dB(A)]	L <sub>W</sub> [dB(A)]
<b>CD...Y3</b>																
<b>IE2 Efficiency according to IEC 60034-30</b>																
63M1-4	0.12	0.33	0.22	1745	69.5	0.66	0.66	3.9	6.1	4.3	0.00046	16	48	60	-	-
63M2-4	0.18	0.44	0.29	1735	74	0.69	0.99	3.3	6.1	3.9	0.00063	17	48	60	-	-
71M1-4	0.25	0.62	0.41	1755	74.5	0.68	1.36	3.6	6.6	4.3	0.00092	24	49	61	-	-
71M2-4	0.37	0.86	0.57	1755	78.5	0.69	2	4.2	7.3	4.5	0.00130	25	49	61	-	-
80M1-4	0.55	1.08	0.72	1755	82	0.78	3	3.4	7.9	4.1	0.00210	31	50	62	-	-
80M2-4	0.75	1.48	0.99	1750	82.5	0.77	4.1	3.7	7.8	4.8	0.0029	35	50	62	-	-
90S-4	1.1	2.05	1.37	1765	84.2	0.8	6	2.8	7.9	3.6	0.0046	44	53	65	-	-
90L-4	1.5	2.8	1.88	1760	84.5	0.79	8.1	3	8.3	3.8	0.0056	46	53	65	-	-
100L1-4	2.2	3.85	2.55	1760	87.6	0.82	11.9	3	8.5	3.8	0.011	59	57	69	-	-
100L2-4	3	5.4	3.6	1755	87.6	0.8	16.3	3.6	8.6	4.2	0.011	59	57	69	-	-
112M-4	4	7.1	4.8	1765	88.4	0.8	21.6	3.6	8.6	4.1	0.022	100	59	71	-	-
132S-4	5.5	9.5	6.3	1765	89.6	0.81	29.8	3.7	8.5	3.9	0.03	113	62	75	59	72
132M-4	7.5	12.4	8.3	1765	90.1	0.84	40.6	3.7	8.6	3.8	0.041	125	62	75	59	72
160M-4	11	17.8	11.9	1770	91.1	0.85	59	3.2	8.4	3.6	0.079	184	67	80	60	73
160L-4	15	24.5	16.3	1770	91.4	0.84	81	3.4	8.5	3.6	0.092	208	67	80	60	73
180M-4	18.5	32	21	1775	92.4	0.79	100	3.8	8.4	3.9	0.155	217	65	78	61	74
180L-4	22	35.5	23.5	1775	92.5	0.84	119	3.7	9	3.8	0.25	244	65	78	61	74
200L-4	30	50	33	1770	93.2	0.82	162	3.5	8.5	3.8	0.25	274	66	80	62	76
225S-4	37	59	39	1775	93.2	0.85	199	3.6	8	3.4	0.4	372	68	82	64	78
225M-4	45	70	47	1778	93.8	0.86	242	3.5	7.8	3.3	0.48	402	68	82	64	78
250M-4	55	84	56	1780	94.2	0.87	295	3.6	8.3	3.5	0.75	588	70	84	68	82
280S-4	75	120	80	1780	94.6	0.83	402	3.7	8.1	3.5	1.25	740	74	88	71	85
280M-4	90	140	93	1787	94.8	0.85	481	3.7	8.1	3.5	1.48	820	74	88	71	85
315S-4	110	173	115	1785	95.1	0.84	589	3	8	2.8	2.2	1040	76	91	72	87
315M-4	132	205	138	1786	95.2	0.84	706	3	8.1	2.8	2.7	1120	76	91	72	87
315L1-4	160	250	165	1786	95.4	0.85	856	3.4	8.2	3.2	3.1	1210	76	91	72	87
315L2-4	200	310	210	1788	96	0.84	1068	3.2	7.7	3	3.9	1430	76	91	72	87
315L3-4	250	370	250	1786	96	0.88	1337	2	8.5	3.1	4.6	1565	76	91	72	87
355L1-4	345	505 <sup>1)</sup>	335	1790	96.3	0.89	1841	1.6	7.3	2.8	6.1	2050	78	94	74	90
355L2-4	390	570 <sup>1)</sup>	380	1790	96.6	0.89	2081	1.7	7.3	3	6.7	2200	78	94	74	90
355L3-4	440	635 <sup>1)</sup>	420 <sup>1)</sup>	1790	97	0.90	2347	1.6	7.4	3	7.4	2430	78	94	74	90
400M-4	495	705 <sup>1)</sup>	470 <sup>1)</sup>	1794	97	0.91	2635	1.15	7.7	2.8	18	2850	84	100	-	-
400L-4	550	780 <sup>1)</sup>	520 <sup>1)</sup>	1794	97.1	0.91	2928	1.15	7.7	2.8	20	3230	84	100	-	-
450M-4	610	865 <sup>1)</sup>	575 <sup>1)</sup>	1794	97.2	0.91	3247	1.05	7.2	2.8	26	3500	85	101	-	-
450L-4	690	975 <sup>1)</sup>	650 <sup>1)</sup>	1794	97.4	0.91	3673	1.05	7.2	2.8	31	3800	85	101	-	-
500..	by request															

**Note**

- 1) Two parallel supply lines are required
- 2) Type B3 with terminal compartment type EAR

The values are also valid for series BD..

# IE3 Partial load data 50 Hz

96

Efficiency [%]

Size CD...Y3	2p=2 P/Pn				2p=4 P/Pn				2p=6 P/Pn			
	0,25	0,5	0,75	1	0,25	0,5	0,75	1	0,25	0,5	0,75	1
63M1	50	63	68	<b>70</b>	53	65	67	<b>68</b>	-	-	-	-
63M2	53	66	71,5	<b>73</b>	60	68	72	<b>72</b>	-	-	-	-
71M1	55	67	73	<b>74</b>	63	71,5	74	<b>73,8</b>	-	-	-	-
71M2	58	71	77	<b>78</b>	63	76	78	<b>77,5</b>	47	62	68	<b>69</b>
80M1	68	79,2	82,3	<b>82,8</b>	67	79,7	80,5	<b>81</b>	47	62	70	<b>72</b>
80M2	70	80,2	83,4	<b>83,7</b>	64,7	77,8	81,7	<b>82,6</b>	51	71	77	<b>77,4</b>
90S	71,9	81,8	84,4	<b>84,7</b>	67,6	79,3	83,3	<b>84,2</b>	60,5	74,2	78,1	<b>79,1</b>
90L	76,4	84,5	86,4	<b>86,4</b>	70	81,9	85	<b>85,5</b>	63	76,3	80,5	<b>81,4</b>
100L1	-	-	-	-	75,5	84,7	86,9	<b>87,1</b>	-	-	-	-
100L/L2	81,8	87,6	88,6	<b>88,1</b>	77	85,1	87,6	<b>87,8</b>	66	77,7	83	<b>83,5</b>
112M	79	86,3	88,1	<b>88,4</b>	78,4	86,5	88,5	<b>88,7</b>	71,8	82,6	85,3	<b>85,5</b>
132S/S1	82,3	88,5	89,7	<b>89,5</b>	79,6	87,3	89,3	<b>89,6</b>	71,9	83,1	85,5	<b>85,7</b>
132S2	83,7	89,5	90,5	<b>90,3</b>	-	-	-	-	-	-	-	-
132M/M1	-	-	-	-	81,4	88,8	90,5	<b>90,5</b>	77,5	85,2	87,1	<b>87</b>
132M2	-	-	-	-	-	-	-	-	77	85,8	88,1	<b>88,3</b>
160M/M1	83,8	89,9	91,2	<b>91,3</b>	82,9	89,6	91,2	<b>91,5</b>	80,5	87,6	89,3	<b>89,4</b>
160M2	86,7	91,3	92,2	<b>92</b>	-	-	-	-	-	-	-	-
160L	88,6	92,2	92,8	<b>92,5</b>	84,1	90,3	91,9	<b>92,1</b>	81	89	90,5	<b>90,5</b>
180M	85,6	91,3	92,7	<b>92,9</b>	86,4	91,6	92,8	<b>92,7</b>	-	-	-	-
180L	-	-	-	-	87,4	92,3	93,3	<b>93,2</b>	83,9	90,1	91,5	<b>91,5</b>
200L/L1	87,7	92,5	93,5	<b>93,5</b>	87,8	92,9	93,9	<b>93,8</b>	87,3	91,9	92,4	<b>92</b>
200L2	88,7	92,9	93,9	<b>93,8</b>	-	-	-	-	87,5	92,1	92,8	<b>92,4</b>
225S	-	-	-	-	88,8	92,9	94	<b>93,9</b>	-	-	-	-
225M	88,6	93,1	94,1	<b>94,2</b>	89,8	93,7	94,5	<b>94,3</b>	87,7	92,4	93,1	<b>93</b>
250M	86,3	92,3	94,2	<b>94,4</b>	90,9	93,9	94,7	<b>94,6</b>	87,1	92,4	93,6	<b>93,5</b>
280S	88,5	93,1	94,3	<b>94,8</b>	89,8	94,1	95,1	<b>95,2</b>	88,6	93,1	93,9	<b>93,9</b>
280M	89	93,3	94,7	<b>95,1</b>	90,8	94,5	95,3	<b>95,3</b>	88,9	93,3	94,3	<b>94,4</b>
315S	92,7	95	95,5	<b>95,4</b>	91,6	94,9	95,6	<b>95,6</b>	91,2	94,5	95,1	<b>94,9</b>
315M	92,3	94,8	95,6	<b>95,8</b>	92,4	95,3	95,9	<b>95,8</b>	91,3	94,7	95,2	<b>95,2</b>
315L1	92,8	95	95,8	<b>95,9</b>	92,6	95,5	96,1	<b>96</b>	91,6	94,9	95,6	<b>95,5</b>
315L2	93	95	95,5	<b>96</b>	93,3	95,8	96,3	<b>96,1</b>	92,3	95,1	95,7	<b>95,6</b>
315L3	92	95,1	95,8	<b>96</b>	92,3	95,2	96,2	<b>96,2</b>	92,6	95,3	95,8	<b>95,8</b>
355M	-	-	-	-	-	-	-	-	93,2	95,7	96	<b>95,9</b>
355L1	93	96,5	96,8	<b>96,6</b>	93	96	96,5	<b>96,3</b>	93,2	95,7	96,1	<b>95,9</b>
355L2	93,3	95,7	96,8	<b>96,8</b>	93,2	96,2	96,6	<b>96,6</b>	93,3	95,8	96,1	<b>96</b>
355L3	93,2	95,7	96,9	<b>96,8</b>	93,6	96,5	97,1	<b>97</b>	-	-	-	-
400M	-	-	-	-	93,9	96,4	96,9	<b>97</b>	94,3	96,4	96,8	<b>96,6</b>
400L	93,7	96,2	97	<b>97</b>	94,4	96,6	97,1	<b>97,1</b>	94,1	96,3	96,8	<b>96,6</b>
450M	-	-	-	-	93,8	96,3	97,1	<b>97,2</b>	93,5	96,4	96,6	<b>96,6</b>
450L	-	-	-	-	95,1	97	97,4	<b>97,4</b>	94,8	96,8	97,1	<b>97</b>

Size CD...Y2	2p=2 P/Pn				2p=4 P/Pn				2p=6 P/Pn			
	0,25	0,5	0,75	1	0,25	0,5	0,75	1	0,25	0,5	0,75	1
63M1	0,48	0,64	0,77	<b>0,83</b>	0,34	0,48	0,6	<b>0,69</b>	-	-	-	-
63M2	0,48	0,65	0,78	<b>0,83</b>	0,37	0,52	0,63	<b>0,71</b>	-	-	-	-
71M1	0,52	0,73	0,83	<b>0,87</b>	0,33	0,52	0,65	<b>0,72</b>	-	-	-	-
71M2	0,51	0,72	0,82	<b>0,85</b>	0,33	0,5	0,63	<b>0,71</b>	0,33	0,49	0,62	<b>0,70</b>
80M1	0,52	0,73	0,83	<b>0,87</b>	0,38	0,58	0,71	<b>0,79</b>	0,32	0,48	0,61	<b>0,71</b>
80M2	0,56	0,75	0,83	<b>0,87</b>	0,38	0,59	0,71	<b>0,78</b>	0,33	0,52	0,65	<b>0,73</b>
90S	0,57	0,76	0,84	<b>0,88</b>	0,39	0,60	0,72	<b>0,80</b>	0,32	0,49	0,61	<b>0,70</b>
90L	0,57	0,77	0,85	<b>0,88</b>	0,39	0,61	0,73	<b>0,81</b>	0,32	0,51	0,64	<b>0,72</b>
100L1	-	-	-	-	0,46	0,68	0,79	<b>0,84</b>	-	-	-	-
100L/L2	0,60	0,79	0,85	<b>0,88</b>	0,45	0,66	0,78	<b>0,84</b>	0,30	0,48	0,63	<b>0,71</b>
112M	0,53	0,74	0,83	<b>0,87</b>	0,43	0,65	0,77	<b>0,83</b>	0,35	0,58	0,71	<b>0,78</b>
132S/S1	0,64	0,82	0,87	<b>0,89</b>	0,47	0,69	0,80	<b>0,85</b>	0,32	0,55	0,67	<b>0,74</b>
132S2	0,64	0,81	0,87	<b>0,89</b>	-	-	-	-	-	-	-	-
132M/M1	-	-	-	-	0,48	0,71	0,81	<b>0,86</b>	0,36	0,57	0,69	<b>0,76</b>
132M2	-	-	-	-	-	-	-	-	0,35	0,59	0,72	<b>0,78</b>
160M/M1	0,56	0,77	0,84	<b>0,87</b>	0,52	0,73	0,82	<b>0,85</b>	0,45	0,67	0,79	<b>0,84</b>
160M2	0,65	0,83	0,88	<b>0,90</b>	-	-	-	-	-	-	-	-
160L	0,66	0,83	0,89	<b>0,91</b>	0,45	0,67	0,78	<b>0,83</b>	0,32	0,60	0,74	<b>0,81</b>
180M	0,64	0,82	0,89	<b>0,91</b>	0,49	0,70	0,79	<b>0,83</b>	-	-	-	-
180L	-	-	-	-	0,43	0,65	0,76	<b>0,81</b>	0,43	0,65	0,76	<b>0,82</b>
200L/L1	0,65	0,82	0,88	<b>0,90</b>	0,50	0,72	0,81	<b>0,85</b>	0,45	0,67	0,77	<b>0,83</b>
200L2	0,68	0,85	0,89	<b>0,90</b>	-	-	-	-	0,47	0,69	0,79	<b>0,84</b>
225S	-	-	-	-	0,57	0,76	0,83	<b>0,85</b>	-	-	-	-
225M	0,67	0,84	0,89	<b>0,90</b>	0,56	0,76	0,83	<b>0,86</b>	0,50	0,72	0,8	<b>0,83</b>
250M	0,60	0,80	0,86	<b>0,88</b>	0,63	0,79	0,86	<b>0,88</b>	0,49	0,71	0,80	<b>0,83</b>
280S	0,67	0,82	0,86	<b>0,88</b>	0,55	0,76	0,82	<b>0,85</b>	0,51	0,72	0,79	<b>0,82</b>
280M	0,65	0,81	0,86	<b>0,87</b>	0,59	0,77	0,83	<b>0,85</b>	0,49	0,71	0,78	<b>0,81</b>
315S	0,74	0,87	0,89	<b>0,89</b>	0,61	0,79	0,83	<b>0,84</b>	0,62	0,8	0,87	<b>0,88</b>
315M	0,75	0,87	0,89	<b>0,90</b>	0,61	0,79	0,83	<b>0,84</b>	0,62	0,81	0,87	<b>0,88</b>
315L1	0,73	0,87	0,90	<b>0,90</b>	0,59	0,77	0,83	<b>0,84</b>	0,60	0,80	0,86	<b>0,88</b>
315L2	0,75	0,87	0,90	<b>0,90</b>	0,58	0,78	0,83	<b>0,85</b>	0,62	0,81	0,86	<b>0,88</b>
315L3	0,79	0,87	0,91	<b>0,92</b>	0,64	0,80	0,85	<b>0,87</b>	0,61	0,8	0,86	<b>0,88</b>
355M	-	-	-	-	-	-	-	-	0,60	0,80	0,86	<b>0,88</b>
355L1	0,83	0,91	0,92	<b>0,92</b>	0,67	0,84	0,89	<b>0,90</b>	0,61	0,81	0,85	<b>0,88</b>
355L2	0,83	0,91	0,92	<b>0,93</b>	0,70	0,85	0,89	<b>0,90</b>	0,61	0,81	0,85	<b>0,88</b>
355L3	0,83	0,91	0,92	<b>0,93</b>	0,70	0,85	0,89	<b>0,90</b>	-	-	-	-
400M	-	-	-	-	0,65	0,83	0,89	<b>0,91</b>	0,68	0,84	0,88	<b>0,89</b>
400L	0,82	0,92	0,93	<b>0,94</b>	0,67	0,85	0,89	<b>0,91</b>	0,68	0,84	0,88	<b>0,89</b>
450M	-	-	-	-	0,68	0,84	0,89	<b>0,91</b>	0,65	0,83	0,88	<b>0,89</b>
450L	-	-	-	-	0,69	0,85	0,90	<b>0,91</b>	0,61	0,83	0,88	<b>0,89</b>

# IE1

## Partial load data 50 Hz

98

Efficiency [%]

Size CD...	2p=2 P/Pn				2p=4 P/Pn				2p=6 P/Pn				2p=8 P/Pn			
	0,25	0,5	0,75	1	0,25	0,5	0,75	1	0,25	0,5	0,75	1	0,25	0,5	0,75	1
63M1	38	53	62	66	40	55	63	67	-	-	-	-	-	-	-	-
63M2	46	61	67	70	50	63	68	70	-	-	-	-	-	-	-	-
71M1	53	65	71	71,5	56	67	69	68,5	-	-	-	-	-	-	-	-
71M2	54	67	71,5	72	60	70	72	71	38	53	60	62	25,5	39,5	46,5	49,5
80M1	58	69	74	74,5	62	71	73	72	44	60	65	67	30	45,5	51,5	54
80M2	63	74	78	78	64	75	76,5	75,5	49	64	68,5	69	34,5	49,5	55,5	58,5
90S	64	75	77	77,8	64	74	76,5	76	54	67	70	70,2	36	51	58	60
90L	68	78,5	81	82	67,5	77,5	79,5	79	55	68,5	72,7	73	43	58	62,5	63
100L1	-	-	-	-	65	77	79,5	80	-	-	-	-	43	58	64,5	67
100L/L2	69	79,5	81,5	82	68	78,5	81,5	81,7	61,5	73	76,8	77	53	65,5	69,3	69
112M	75	84	85,5	85	75	83	85,2	85	68	77,5	80,5	81	60	71,5	75	76
132S/S1	70	81	84,5	85,5	77	85	86,8	86,5	71,6	80,1	82,5	82,6	65,5	75,7	78	77
132S2	74	83,5	86	86,5	-	-	-	-	-	-	-	-	-	-	-	-
132M/M1	-	-	-	-	79,5	87	88,3	88	72,1	81	83,5	83,6	68,5	78,5	80,9	80,5
132M2	-	-	-	-	-	-	-	-	76,8	84	84,7	84,6	-	-	-	-
160M/M1	76	86	88,5	89	81,5	87,7	89,7	89,5	77,3	84,2	86,1	86,1	71,3	80,8	83,7	83,8
160M2	81	87,5	89	89	-	-	-	-	-	-	-	-	73,2	82,2	84,9	84,7
160L	83,5	89,5	90,7	90,5	83,7	89,3	90,3	90	81,5	87	88	87,5	76,7	83,5	85,2	85,2
180M	86,6	91	91,5	91,2	85,8	90,8	91,5	91	-	-	-	-	-	-	-	-
180L	-	-	-	-	88,2	91,3	91,8	91,5	82,6	88,8	89,3	89,1	80,1	86,4	87,6	87,1
200L/L1	85,6	90,7	92,1	92	88,2	92,3	92,5	92,2	86,2	89,7	90	89,7	84,5	88,5	89	88,5
200L2	86	91,8	92,5	92,5	-	-	-	-	85,5	89,6	90,4	90,4	-	-	-	-
225S	-	-	-	-	87,9	92	92,7	92,6	-	-	-	-	81,5	87,7	89	89
225M	86	91,5	92,7	92,8	88,1	92,2	92,9	92,8	86,5	90,7	91,3	90,9	82,8	88,3	89,7	89,5
250M	86,3	91,8	93,1	93,2	89,8	92,9	93,8	93,2	86,5	90,9	91,6	91,4	87,6	89,6	90,3	90,1
280S	87,6	92,3	93,4	93,6	90	93,3	94	93,8	87,4	91,8	92,5	92,4	86,3	90,3	90,8	91,1
280M	88	92,5	93,7	93,8	90,1	93,4	94,1	94	87,6	92	92,6	92,5	86,6	90,8	91,5	91,3
315S	91,6	93,9	94,3	94	90,9	93,5	94,3	94,2	90	92,8	93,4	93	87,3	91,3	92,2	91,8
315M	91,3	93,8	94,2	94,3	90,9	93,6	94,5	94,4	90,1	93	93,6	93,3	88,1	92,1	93	92,6
315L1	91,7	94	94,3	94,5	91,2	94,1	94,9	94,7	90,6	93,3	94	93,6	88,6	92,4	93,1	92,8
315L2	91,9	94,1	94,5	94,7	91,5	94,2	95	94,9	91,1	93,6	94,2	93,8	89,3	92,8	93,4	93
315L3	92	95,1	95,8	96	92,3	95,2	96,2	96,2	91,6	94,2	94,6	94,3	89,7	92,9	93,5	93,1
355M	-	-	-	-	-	-	-	-	92,3	94,8	95	94,8	91	94,5	95	95,1
355L1	93	96,5	96,8	96,6	93	96	96,5	96,3	93,2	95,7	96,1	95,9	91,5	94,8	95,5	95,8
355L2	93,3	95,7	96,8	96,8	93,2	96,2	96,6	96,6	93,3	95,8	96,1	96	91,6	94,9	95,5	95,6
355L3	93,2	95,7	96,9	96,8	93,6	96,5	97,1	97	-	-	-	-	-	-	-	-
400M	-	-	-	-	93,9	96,4	96,9	97	94,3	96,4	96,8	96,6	94	95,8	96,3	96,2
400L	93,7	96,2	97	97	94,4	96,6	97,1	97,1	94,1	96,3	96,8	96,6	93,5	95,7	96,3	96,3
450M	-	-	-	-	93,8	96,3	97,1	97,2	93,5	96,4	96,6	96,6	94,1	96,3	96,7	96,6
450L	-	-	-	-	95,1	97	97,4	97,4	94,8	96,8	97,1	97	94,5	96,4	96,8	96,7

Size CD...	2p=2 P/Pn				2p=4 P/Pn				2p=6 P/Pn				2p=8 P/Pn			
	0,25	0,5	0,75	1	0,25	0,5	0,75	1	0,25	0,5	0,75	1	0,25	0,5	0,75	1
63M1	0,38	0,50	0,60	<b>0,67</b>	0,31	0,42	0,52	<b>0,60</b>	-	-	-	-	-	-	-	-
63M2	0,41	0,56	0,67	<b>0,75</b>	0,35	0,49	0,61	<b>0,70</b>	-	-	-	-	-	-	-	-
71M1	0,49	0,65	0,78	<b>0,84</b>	0,42	0,62	0,73	<b>0,80</b>	-	-	-	-	-	-	-	-
71M2	0,48	0,64	0,76	<b>0,82</b>	0,42	0,62	0,73	<b>0,80</b>	0,36	0,49	0,61	<b>0,71</b>	0,36	0,46	0,56	<b>0,65</b>
80M1	0,53	0,70	0,80	<b>0,84</b>	0,43	0,62	0,74	<b>0,80</b>	0,33	0,48	0,61	<b>0,71</b>	0,34	0,46	0,56	<b>0,65</b>
80M2	0,45	0,67	0,78	<b>0,82</b>	0,42	0,61	0,72	<b>0,79</b>	0,36	0,52	0,64	<b>0,72</b>	0,31	0,43	0,53	<b>0,64</b>
90S	0,48	0,69	0,80	<b>0,86</b>	0,46	0,66	0,77	<b>0,83</b>	0,37	0,55	0,67	<b>0,75</b>	0,31	0,44	0,56	<b>0,65</b>
90L	0,48	0,69	0,79	<b>0,85</b>	0,45	0,65	0,77	<b>0,82</b>	0,35	0,52	0,64	<b>0,73</b>	0,30	0,44	0,57	<b>0,65</b>
100L1	-	-	-	-	0,39	0,60	0,72	<b>0,80</b>	-	-	-	-	0,32	0,44	0,56	<b>0,66</b>
100L/L2	0,50	0,70	0,80	<b>0,87</b>	0,44	0,65	0,76	<b>0,82</b>	0,35	0,54	0,67	<b>0,75</b>	0,35	0,50	0,64	<b>0,73</b>
112M	0,59	0,78	0,85	<b>0,88</b>	0,44	0,65	0,77	<b>0,84</b>	0,36	0,54	0,66	<b>0,75</b>	0,30	0,47	0,56	<b>0,67</b>
132S/S1	0,56	0,76	0,84	<b>0,87</b>	0,50	0,70	0,80	<b>0,85</b>	0,37	0,57	0,69	<b>0,78</b>	0,41	0,60	0,72	<b>0,79</b>
132S2	0,55	0,75	0,83	<b>0,87</b>	-	-	-	-	-	-	-	-	-	-	-	-
132M/M1	-	-	-	-	0,51	0,72	0,81	<b>0,86</b>	0,38	0,57	0,72	<b>0,79</b>	0,39	0,58	0,70	<b>0,77</b>
132M2	-	-	-	-	-	-	-	-	0,41	0,62	0,75	<b>0,81</b>	-	-	-	-
160M/M1	0,62	0,80	0,86	<b>0,89</b>	0,51	0,72	0,81	<b>0,85</b>	0,49	0,70	0,80	<b>0,85</b>	0,41	0,61	0,72	<b>0,78</b>
160M2	0,71	0,86	0,90	<b>0,91</b>	-	-	-	-	-	-	-	-	0,39	0,59	0,71	<b>0,77</b>
160L	0,72	0,87	0,91	<b>0,92</b>	0,56	0,76	0,83	<b>0,86</b>	0,53	0,73	0,82	<b>0,86</b>	0,37	0,58	0,70	<b>0,77</b>
180M	0,72	0,86	0,89	<b>0,92</b>	0,51	0,73	0,81	<b>0,84</b>	-	-	-	-	-	-	-	-
180L	-	-	-	-	0,53	0,74	0,81	<b>0,84</b>	0,48	0,70	0,79	<b>0,84</b>	0,39	0,61	0,74	<b>0,79</b>
200L/L1	0,65	0,83	0,88	<b>0,90</b>	0,60	0,79	0,86	<b>0,88</b>	0,51	0,72	0,80	<b>0,84</b>	0,40	0,60	0,74	<b>0,80</b>
200L2	0,68	0,85	0,89	<b>0,91</b>	-	-	-	-	0,5	0,71	0,82	<b>0,85</b>	-	-	-	-
225S	-	-	-	-	0,63	0,82	0,87	<b>0,88</b>	-	-	-	-	0,40	0,62	0,73	<b>0,79</b>
225M	0,65	0,84	0,88	<b>0,89</b>	0,62	0,81	0,86	<b>0,88</b>	0,52	0,72	0,81	<b>0,84</b>	0,39	0,61	0,73	<b>0,79</b>
250M	0,70	0,88	0,89	<b>0,89</b>	0,64	0,82	0,88	<b>0,89</b>	0,53	0,74	0,81	<b>0,84</b>	0,47	0,69	0,78	<b>0,82</b>
280S	0,69	0,85	0,89	<b>0,89</b>	0,62	0,80	0,85	<b>0,86</b>	0,53	0,74	0,8	<b>0,83</b>	0,45	0,66	0,77	<b>0,82</b>
280M	0,72	0,88	0,90	<b>0,90</b>	0,62	0,80	0,85	<b>0,86</b>	0,53	0,74	0,81	<b>0,82</b>	0,45	0,68	0,78	<b>0,82</b>
315S	0,74	0,87	0,89	<b>0,89</b>	0,62	0,80	0,84	<b>0,85</b>	0,58	0,78	0,85	<b>0,87</b>	0,46	0,68	0,78	<b>0,83</b>
315M	0,75	0,87	0,89	<b>0,89</b>	0,62	0,80	0,84	<b>0,85</b>	0,62	0,81	0,87	<b>0,88</b>	0,47	0,69	0,79	<b>0,83</b>
315L1	0,73	0,87	0,90	<b>0,90</b>	0,59	0,79	0,85	<b>0,86</b>	0,60	0,80	0,86	<b>0,88</b>	0,47	0,68	0,79	<b>0,83</b>
315L2	0,75	0,87	0,90	<b>0,90</b>	0,58	0,78	0,85	<b>0,86</b>	0,62	0,81	0,86	<b>0,88</b>	0,47	0,68	0,78	<b>0,82</b>
315L3	0,79	0,87	0,91	<b>0,92</b>	0,64	0,80	0,85	<b>0,87</b>	0,61	0,8	0,86	<b>0,88</b>	0,48	0,69	0,78	<b>0,82</b>
355M	-	-	-	-	-	-	-	-	0,60	0,80	0,86	<b>0,88</b>	0,45	0,67	0,78	<b>0,83</b>
355L1	0,83	0,91	0,92	<b>0,92</b>	0,67	0,84	0,89	<b>0,90</b>	0,61	0,81	0,85	<b>0,88</b>	0,46	0,67	0,78	<b>0,82</b>
355L2	0,83	0,91	0,92	<b>0,93</b>	0,70	0,85	0,89	<b>0,90</b>	0,61	0,81	0,85	<b>0,88</b>	0,48	0,69	0,79	<b>0,82</b>
355L3	0,83	0,91	0,92	<b>0,93</b>	0,70	0,85	0,89	<b>0,90</b>	-	-	-	-	-	-	-	-
400M	-	-	-	-	0,65	0,83	0,89	<b>0,91</b>	0,68	0,84	0,88	<b>0,89</b>	0,50	0,71	0,80	<b>0,83</b>
400L	0,82	0,92	0,93	<b>0,94</b>	0,67	0,85	0,89	<b>0,91</b>	0,68	0,84	0,88	<b>0,89</b>	0,49	0,71	0,80	<b>0,83</b>
450M	-	-	-	-	0,68	0,84	0,89	<b>0,91</b>	0,65	0,83	0,88	<b>0,89</b>	0,53	0,74	0,81	<b>0,84</b>
450L	-	-	-	-	0,69	0,85	0,90	<b>0,91</b>	0,61	0,83	0,88	<b>0,89</b>	0,54	0,75	0,82	<b>0,84</b>

ATTENTION: From 01.07.2021, motors with efficiency classes IE1 and IE2 may only be supplied to the EU area as replacement motors for identical ATB motors that are already in operation.

# IE2

## Partial load data 50 Hz

100

Efficiency [%]

Baugröße CD...Y2	2p=2 P/Pn				2p=4 P/Pn				2p=6 P/Pn			
	0,25	0,5	0,75	1	0,25	0,5	0,75	1	0,25	0,5	0,75	1
63M1	38	53	62	<b>66</b>	40	55	63	<b>67</b>	-	-	-	-
63M2	46	61	67	<b>70</b>	50	63	68	<b>70</b>	-	-	-	-
71M1	56,5	67,5	72,5	<b>73</b>	62	71	73	<b>72,5</b>	-	-	-	-
71M2	63	73	77	<b>77</b>	64	74	76	<b>76,5</b>	47,5	62,5	67	<b>67,5</b>
80M1	64	75,5	78,5	<b>79</b>	58,8	74,8	78,8	<b>79,5</b>	49,5	64,5	70,5	<b>72,5</b>
80M2	64,5	77,7	80,6	<b>81,1</b>	63,5	76,5	80	<b>81</b>	55	70	75,5	<b>76</b>
90S	70,2	79,9	82,4	<b>82,7</b>	66,5	78	82	<b>82,7</b>	57	71,5	76	<b>77,4</b>
90L	74,7	82,6	84,5	<b>84,5</b>	68,5	80,5	83,5	<b>84</b>	62,5	75	78,8	<b>79,5</b>
100L1	-	-	-	-	74	83	85,5	<b>85,5</b>	-	-	-	-
100L/L2	79,7	85,3	86,3	<b>85,8</b>	76	84	86,5	<b>86,6</b>	64	75,5	80,6	<b>81,1</b>
112M	77,7	84,8	86,6	<b>86,9</b>	77,4	85,4	87,4	<b>87,6</b>	70	80,2	82,8	<b>83</b>
132S/S1	81	87,1	88,2	<b>88,1</b>	78,7	86,3	88,3	<b>88,6</b>	71	81,8	84	<b>84,4</b>
132S2	82,6	88,3	89,3	<b>89,1</b>	-	-	-	-	-	-	-	-
132M/M1	-	-	-	-	80,4	87,8	89,5	<b>89,5</b>	76,3	84	85,8	<b>85,7</b>
132M2	-	-	-	-	-	-	-	-	75,8	84,5	86,8	<b>87</b>
160M/M1	82,9	88,9	90,2	<b>90,3</b>	82	88,7	90,4	<b>90,6</b>	79,3	86,3	88	<b>88,1</b>
160M2	85,9	90,4	91,3	<b>91,1</b>	-	-	-	-	-	-	-	-
160L	87,7	91,3	91,9	<b>91,6</b>	82,9	89,4	91,1	<b>91,3</b>	78,5	86,3	89,3	<b>89,5</b>
180M	84,7	90,4	91,8	<b>92</b>	85,7	90,8	92	<b>91,9</b>	-	-	-	-
180L	-	-	-	-	86,6	91,4	92,4	<b>92,3</b>	82,9	89	90,4	<b>90,4</b>
200L/L1	86	91,2	92,5	<b>92,7</b>	87	92	93	<b>92,9</b>	86	89,5	91,4	<b>91</b>
200L2	86	91,7	93	<b>93,1</b>	-	-	-	-	86,7	91,2	92	<b>91,5</b>
225S	-	-	-	-	88	92,4	93,5	<b>93,3</b>	-	-	-	-
225M	88,5	92,4	93,3	<b>93,4</b>	89,1	93	93,8	<b>93,6</b>	87,1	91,7	92,4	<b>92,3</b>
250M	86,5	91,8	93,5	<b>93,8</b>	90,3	93,4	94,1	<b>94</b>	86,3	91,6	92,8	<b>92,7</b>
280S	88,2	92,8	93,9	<b>94,2</b>	89,3	93,5	94,4	<b>94,5</b>	88,4	92,8	93,6	<b>93,5</b>
280M	88,7	93	94,2	<b>94,5</b>	90,3	93,9	94,7	<b>94,7</b>	88,7	92,9	93,6	<b>93,6</b>
315S	92,5	94,8	95	<b>94,8</b>	91	94,1	95	<b>94,9</b>	91	93,8	94,5	<b>94,1</b>
315M	92,4	94,7	95	<b>95</b>	91,5	94,3	95,1	<b>95,1</b>	91	94	94,6	<b>94,4</b>
315L1	92,5	94,8	95,1	<b>95,2</b>	91,7	94,7	95,3	<b>95,3</b>	91,5	94,2	94,9	<b>94,7</b>
315L2	92,7	94,9	95,2	<b>95,4</b>	92	94,8	95,6	<b>95,5</b>	92	94,5	95,2	<b>95</b>
315L3	92	95,1	95,8	<b>96</b>	92,3	95,2	96,2	<b>96,2</b>	92,3	94,9	95,5	<b>95,2</b>
355M	-	-	-	-	-	-	-	-	93	95,5	95,8	<b>95,5</b>
355L1	93	96,5	96,8	<b>96,6</b>	93	96	96,5	<b>96,3</b>	93,2	95,7	96,1	<b>95,9</b>
355L2	93,3	95,7	96,8	<b>96,8</b>	93,2	96,2	96,6	<b>96,6</b>	93,3	95,8	96,1	<b>96</b>
355L3	93,2	95,7	96,9	<b>96,8</b>	93,6	96,5	97,1	<b>97</b>	-	-	-	-
400M	-	-	-	-	93,9	96,4	96,9	<b>97</b>	94,3	96,4	96,8	<b>96,6</b>
400L	93,7	96,2	97	<b>97</b>	94,4	96,6	97,1	<b>97,1</b>	94,1	96,3	96,8	<b>96,6</b>
450M	-	-	-	-	93,8	96,3	97,1	<b>97,2</b>	93,5	96,4	96,6	<b>96,6</b>
450L	-	-	-	-	95,1	97	97,4	<b>97,4</b>	94,8	96,8	97,1	<b>97</b>

Size CD...Y2	2p=2 P/Pn				2p=4 P/Pn				2p=6 P/Pn			
	0,25	0,5	0,75	1	0,25	0,5	0,75	1	0,25	0,5	0,75	1
63M1	0,48	0,64	0,77	<b>0,83</b>	0,34	0,48	0,6	<b>0,69</b>	-	-	-	-
63M2	0,48	0,65	0,78	<b>0,83</b>	0,37	0,52	0,63	<b>0,71</b>	-	-	-	-
71M1	0,52	0,73	0,83	<b>0,87</b>	0,33	0,52	0,65	<b>0,72</b>	-	-	-	-
71M2	0,51	0,72	0,82	<b>0,85</b>	0,33	0,5	0,63	<b>0,71</b>	0,33	0,49	0,62	<b>0,70</b>
80M1	0,52	0,73	0,83	<b>0,87</b>	0,38	0,58	0,71	<b>0,79</b>	0,32	0,48	0,61	<b>0,71</b>
80M2	0,56	0,75	0,83	<b>0,87</b>	0,38	0,59	0,71	<b>0,78</b>	0,33	0,52	0,65	<b>0,73</b>
90S	0,57	0,76	0,84	<b>0,88</b>	0,39	0,60	0,72	<b>0,80</b>	0,32	0,49	0,61	<b>0,70</b>
90L	0,57	0,77	0,85	<b>0,88</b>	0,39	0,61	0,73	<b>0,81</b>	0,32	0,51	0,64	<b>0,72</b>
100L1	-	-	-	-	0,46	0,68	0,79	<b>0,84</b>	-	-	-	-
100L/L2	0,60	0,79	0,85	<b>0,88</b>	0,45	0,66	0,78	<b>0,84</b>	0,30	0,48	0,63	<b>0,71</b>
112M	0,53	0,74	0,83	<b>0,87</b>	0,43	0,65	0,77	<b>0,83</b>	0,35	0,58	0,71	<b>0,78</b>
132S/S1	0,64	0,82	0,87	<b>0,89</b>	0,47	0,69	0,80	<b>0,85</b>	0,32	0,55	0,67	<b>0,74</b>
132S2	0,64	0,81	0,87	<b>0,89</b>	-	-	-	-	-	-	-	-
132M/M1	-	-	-	-	0,48	0,71	0,81	<b>0,86</b>	0,36	0,57	0,69	<b>0,76</b>
132M2	-	-	-	-	-	-	-	-	0,35	0,59	0,72	<b>0,78</b>
160M/M1	0,56	0,77	0,84	<b>0,87</b>	0,52	0,73	0,82	<b>0,85</b>	0,45	0,67	0,79	<b>0,84</b>
160M2	0,65	0,83	0,88	<b>0,90</b>	-	-	-	-	-	-	-	-
160L	0,66	0,83	0,89	<b>0,91</b>	0,45	0,67	0,78	<b>0,83</b>	0,32	0,60	0,74	<b>0,81</b>
180M	0,64	0,82	0,89	<b>0,91</b>	0,49	0,70	0,79	<b>0,83</b>	-	-	-	-
180L	-	-	-	-	0,43	0,65	0,76	<b>0,81</b>	0,43	0,65	0,76	<b>0,82</b>
200L/L1	0,65	0,82	0,88	<b>0,90</b>	0,50	0,72	0,81	<b>0,85</b>	0,45	0,67	0,77	<b>0,83</b>
200L2	0,68	0,85	0,89	<b>0,90</b>	-	-	-	-	0,47	0,69	0,79	<b>0,84</b>
225S	-	-	-	-	0,57	0,76	0,83	<b>0,85</b>	-	-	-	-
225M	0,67	0,84	0,89	<b>0,90</b>	0,56	0,76	0,83	<b>0,86</b>	0,50	0,72	0,8	<b>0,83</b>
250M	0,60	0,80	0,86	<b>0,88</b>	0,63	0,79	0,86	<b>0,88</b>	0,49	0,71	0,80	<b>0,83</b>
280S	0,67	0,82	0,86	<b>0,88</b>	0,55	0,76	0,82	<b>0,85</b>	0,51	0,72	0,79	<b>0,82</b>
280M	0,65	0,81	0,86	<b>0,87</b>	0,59	0,77	0,83	<b>0,85</b>	0,49	0,71	0,78	<b>0,81</b>
315S	0,74	0,87	0,89	<b>0,89</b>	0,61	0,79	0,83	<b>0,84</b>	0,62	0,8	0,87	<b>0,88</b>
315M	0,75	0,87	0,89	<b>0,90</b>	0,61	0,79	0,83	<b>0,84</b>	0,62	0,81	0,87	<b>0,88</b>
315L1	0,73	0,87	0,90	<b>0,90</b>	0,59	0,77	0,83	<b>0,84</b>	0,60	0,80	0,86	<b>0,88</b>
315L2	0,75	0,87	0,90	<b>0,90</b>	0,58	0,78	0,83	<b>0,85</b>	0,62	0,81	0,86	<b>0,88</b>
315L3	0,79	0,87	0,91	<b>0,92</b>	0,64	0,80	0,85	<b>0,87</b>	0,61	0,8	0,86	<b>0,88</b>
355M	-	-	-	-	-	-	-	-	0,60	0,80	0,86	<b>0,88</b>
355L1	0,83	0,91	0,92	<b>0,92</b>	0,67	0,84	0,89	<b>0,90</b>	0,61	0,81	0,85	<b>0,88</b>
355L2	0,83	0,91	0,92	<b>0,93</b>	0,70	0,85	0,89	<b>0,90</b>	0,61	0,81	0,85	<b>0,88</b>
355L3	0,83	0,91	0,92	<b>0,93</b>	0,70	0,85	0,89	<b>0,90</b>	-	-	-	-
400M	-	-	-	-	0,65	0,83	0,89	<b>0,91</b>	0,68	0,84	0,88	<b>0,89</b>
400L	0,82	0,92	0,93	<b>0,94</b>	0,67	0,85	0,89	<b>0,91</b>	0,68	0,84	0,88	<b>0,89</b>
450M	-	-	-	-	0,68	0,84	0,89	<b>0,91</b>	0,65	0,83	0,88	<b>0,89</b>
450L	-	-	-	-	0,69	0,85	0,90	<b>0,91</b>	0,61	0,83	0,88	<b>0,89</b>

# Increased performance Mains operation 50 Hz

102

Temperature class T4,  
ns = 3000 rpm, 2p = 2

40 °C ambient temperature. winding heating within heat class F

Size	Output	Rated current at		Speed	Efficiency	Power factor	Torque	Starting torque	Starting current	Breakdown torque	Mass moment of inertia	Weight <sup>1)</sup>	Noise values with radial fan	
		400 V	500 V										L <sub>P</sub>	L <sub>W</sub>
CD...X	P <sub>2</sub> [kW]	I [A]	I [A]	n [rpm]	η [%]	cos φ	M [Nm]	M <sub>A</sub> / M <sub>N</sub>	I <sub>A</sub> / I <sub>N</sub>	M <sub>K</sub> / M <sub>N</sub>	J [kgm <sup>2</sup> ]	m [kg]	[dB(A)]	[dB(A)]
<b>Efficiency according to manufacturer's standard</b>														
63M1-2	0.25	0.69	0.55	2860	70	0.75	0.83	3.4	5.8	4.7	0.00028	16	49	61
63M2-2	0.37	0.89	0.71	2800	71.5	0.84	1.26	2.7	5.2	3.5	0.00028	16	49	61
71M1-2	0.46	1.43	1.15	2720	66	0.84	1.62	2.1	4.2	2.5	0.00028	16	57	69
71M2-2	0.75	1.91	1.53	2730	70	0.81	2.62	2.7	4.7	3.2	0.00039	17	57	69
80M1-2	1	2.65	2.1	2750	68	0.80	3.47	2.4	4.2	3	0.00058	24	59	71
80M2-2	1.4	3.3	2.65	2805	76.5	0.80	4.8	3.2	5.6	3.6	0.0008	25	59	71
90S-2	1.9	4.2	3.35	2830	78	0.84	6.4	2.2	5.8	3.1	0.0013	31	60	72
90L-2	2.7	6.2	4.95	2830	78	0.81	9.1	2.5	5.5	3.5	0.0018	35	60	72
100L-2	3.4	7.5	6	2845	80	0.82	11.4	2.8	5.8	3.5	0.0029	45	64	76
112M-2	5	9.9	7.9	2870	83.5	0.87	16.6	2.3	6.8	3	0.0051	53	66	78
132S1-2	6.6	14.3	11.4	2900	81.5	0.82	21.7	2.7	6.4	3.2	0.0089	95	69	82
132S2-2	9	18.7	15	2910	83.5	0.83	29.5	2.7	6.8	3.5	0.0125	100	69	82
160M1-2	13.5	27	21.5	2930	86	0.84	44	2.5	6.9	3.2	0.032	163	80	93
160M2-2	18.5	34.5	27.5	2910	87.5	0.89	61	2.5	6.5	3.2	0.043	173	80	93
160L-2	22	39.5	31.5	2915	89	0.90	72	2.8	6.9	3.4	0.052	188	80	93
180M-2	30	55	44	2915	89.5	0.88	98	2.7	6.9	3.1	0.075	196	83	96
200L1-2	37	66	53	2955	91.4	0.89	120	3	7.2	3.3	0.13	254	85	99
200L2-2	45	81	65	2955	92	0.87	145	2.8	7.2	3.3	0.16	278	85	99
225M-2	55	103	81	2965	92.6	0.84	177	2.9	7.1	3.7	0.24	400	87	101
250M-2	70	139	111	2970	91	0.80	225	2.9	7.2	3.5	0.4	545	87	101
280S-2	90	162	130	2970	92.2	0.87	289	2.2	6.6	2.5	0.65	700	89	103
280M-2	110	200	161	2975	93	0.85	353	2.4	7.3	2.6	0.78	762	89	103
315S-2	132	230	185	2975	93.6	0.88	424	1.9	6.5	2.3	1.4	960	90	105
315M-2	160	280	225	2975	93	0.89	514	1.8	6.7	2.4	1.6	1025	90	105
315L1-2	200	345	255	2975	93.5	0.89	594	2	6.9	2.6	1.9	1065	90	105
315L2-2	230	400	320	2975	93.5	0.89	738	2	6.9	2.6	2.2	1270	90	105

**Note:**

1) Type B3 with terminal compartment type EAR

The values are also valid for series BD..

40 °C ambient temperature. winding heating within heat class F

Size	Output	Rated current at		Speed	Efficiency	Power factor	Torque	Starting torque	Starting current	Break down torque	Mass moment of inertia	Weight <sup>2)</sup>	Noise values with radial fan	
		400 V	500 V										L <sub>P</sub>	L <sub>W</sub>
CD...X	P <sub>2</sub>	I	I	n	η	cos φ	M	M <sub>A</sub> / M <sub>N</sub>	I <sub>A</sub> / I <sub>N</sub>	M <sub>K</sub> / M <sub>N</sub>	J	m	[dB(A)]	[dB(A)]
	[kW]	[A]	[A]	[rpm]	[%]		[Nm]				[kgm <sup>2</sup> ]	[kg]		
<b>Efficiency according to manufacturer's standard</b>														
63M1-4	0.18	0.53	0.42	1415	70	0.70	1.2	2.7	4.7	2.7	0.00046	16	44	56
63M2-4	0.25	0.66	0.53	1370	68.5	0.80	1.74	2	3.9	2.5	0.00046	16	44	56
71M1-4	0.37	1.03	0.82	1350	65	0.80	2.62	1.7	3.6	2.3	0.00046	16	46	58
71M2-4	0.5	1.42	1.15	1335	67	0.79	3.58	2.1	3.6	2.7	0.00063	17	46	58
80M1-4	0.7	1.87	1.50	1370	70	0.77	4.9	2.2	3.5	2.4	0.00092	24	47	59
80M2-4	1	2.55	2.05	1380	74	0.77	6.9	2.3	4.1	2.5	0.0013	25	47	59
90S-4	1.4	3.25	2.6	1380	75.5	0.83	9.7	2	4.9	2.5	0.0021	31	49	61
90L-4	2	4.6	3.7	1360	75	0.83	14	2	4.2	2.2	0.0029	35	49	61
100L1-4	2.5	6.2	4.9	1415	76	0.77	16.9	2.3	5.7	2.7	0.0046	44	52	64
100L2-4	3.4	7.6	6.1	1400	78.8	0.82	23.2	2.1	5.5	2.8	0.0056	46	52	64
112M-4	5	11.1	8.9	1420	81	0.80	33.6	2.6	6.4	3	0.011	59	54	66
132S-4	6.6	13.4	10.7	1435	83.6	0.85	44	2.6	6.3	2.9	0.022	100	59	72
132M-4	9	18.3	14.6	1435	85.7	0.83	60	2.7	6.3	3	0.03	110	59	72
160M-4	13.5	27.5	22	1460	87.5	0.81	88	2.6	6.9	3	0.057	168	67	80
160L-4	17.5	34	27	1455	88.6	0.84	115	2.5	6.8	2.9	0.079	184	67	80
180M-4	22	43.5	35	1460	90	0.81	144	3.1	6.7	3.2	0.13	198	73	86
180L-4	27	52	42	1460	91	0.82	177	3	7.2	3.1	0.155	217	73	86
200L-4	37	68	55	1460	91	0.86	242	2.9	7.2	3	0.25	274	76	90
225S-4	45	81	65	1465	92	0.87	293	2.6	6.5	2.6	0.4	372	79	93
225M-4	55	100	80	1475	92.5	0.86	356	2.6	6.5	2.8	0.48	402	79	93
250M-4	70	127	102	1475	92.5	0.86	453	2.9	7.2	3.4	0.75	573	80	94
280S-4	90	168	134	1480	93.2	0.83	581	2.9	6.9	2.6	1.25	740	82	96
280M-4	110	200	161	1480	93.7	0.84	710	2.9	7	2.7	1.48	820	82	96
315S-4	132	245	194	1480	93.5	0.84	851	2.6	6.9	2.4	2.2	1040	84	99
315M-4	160	290	230	1480	94	0.85	1032	2.6	6.5	2.3	2.7	1120	84	99
315L1-4	200	360	290	1485	94.3	0.85	1190	2.7	6.9	2.5	3.3	1210	84	99
315L2-4	230	410 <sup>1)</sup>	325	1485	94.7	0.86	1479	2.7	6.9	2.5	3.9	1430	84	99

**Note:**

- 1) Two parallel supply lines are required
- 2) Type B3 with terminal compartment type EAR

The values are also valid for series BD..

# Increased performance Mains operation 60 Hz

104

Temperature class T4,  
ns = 3600 rpm, 2p = 2

40 °C ambient temperature. winding heating within heat class F

Size	Output	Rated current at		Speed	Efficiency	Power factor	Torque	Starting torque	Starting current	Breakdown torque	Mass moment of inertia	Weight <sup>1)</sup>	Noise values with radial fan	
		460 V	690 V										L <sub>P</sub>	L <sub>W</sub>
CD...X	P <sub>2</sub> [kW]	I [A]	I [A]	n [rpm]	η [%]	cos φ	M [Nm]	M <sub>A</sub> / M <sub>N</sub>	I <sub>A</sub> / I <sub>N</sub>	M <sub>K</sub> / M <sub>N</sub>	J [kgm <sup>2</sup> ]	m [kg]	L <sub>P</sub> [dB(A)]	L <sub>W</sub> [dB(A)]
<b>Efficiency according to manufacturer's standard</b>														
63M1-2	0.29	0.69	0.46	3430	70	0.75	0.81	3.4	5.8	4.7	0.00028	16	53	65
63M2-2	0.44	0.92	0.61	3360	71.5	0.84	1.25	2.7	5.2	3.5	0.00028	16	53	65
71M1-2	0.53	1.20	0.80	3265	66	0.84	1.62	2.1	4.2	2.5	0.00028	16	61	73
71M2-2	0.87	1.93	1.28	3275	70	0.81	2.54	2.7	4.7	3.2	0.00039	17	61	73
80M1-2	1.16	2.7	1.78	3300	68	0.80	3.46	2.4	4.2	3	0.00058	24	63	75
80M2-2	1.6	3.3	2.2	3365	76.5	0.80	4.5	3.2	5.6	3.6	0.0008	25	63	75
90S-2	2.2	4.2	2.8	3395	78	0.84	6.3	2.2	5.8	3.1	0.0013	31	64	76
90L-2	3.1	6.2	4.1	3395	78	0.81	8.7	2.5	5.5	3.5	0.0018	35	64	76
100L-2	3.9	7.5	4.95	3415	80	0.82	10.9	2.8	5.8	3.5	0.0029	45	68	80
112M-2	5.8	10	6.7	3445	83.5	0.87	16.1	2.3	6.8	3	0.0051	53	70	82
132S1-2	7.6	14.3	9.5	3495	81.5	0.82	21	2.7	6.4	3.2	0.0089	95	73	86
132S2-2	10.4	18.8	12.6	3495	83.5	0.83	28.4	2.7	6.8	3.5	0.0125	100	73	86
160M1-2	15.5	27	18	3505	86	0.84	42	2.5	6.9	3.2	0.032	163	85	98
160M2-2	22	35.5	23.5	3490	87.5	0.89	60	2.5	6.5	3.2	0.043	173	85	98
160L-2	26	40.5	27	3500	89	0.90	71	2.8	6.9	3.4	0.052	188	85	98
180M-2	35	56	37	3500	89.5	0.88	96	2.7	6.9	3.1	0.075	196	88	101
200L1-2	43	66	44	3545	91.4	0.89	116	3	7.2	3.3	0.13	254	90	104
200L2-2	52	82	54	3545	92	0.87	140	2.8	7.2	3.3	0.16	278	90	104
225M-2	64	104	69	3560	92	0.84	172	2.9	7.1	3.7	0.24	400	92	106
250M-2	81	140	93	3565	91	0.80	217	2.9	7.2	3.5	0.4	545	92	106
280S-2	105	165	110	3565	92	0.87	281	2.2	6.6	2.5	0.65	700	95	109
280M-2	121	193	128	3565	92.8	0.85	324	2.4	7.3	2.6	0.78	762	95	109
315S-2	145	220	147	3570	93.6	0.88	388	2	6.9	2.4	1.4	960	96	111
315M-2	176	265	178	3570	93	0.89	471	1.9	7.1	2.5	1.6	1025	96	111
315L1-2	220	330	220	3570	93.5	0.89	548	2.2	7.3	2.7	1.9	1065	96	111
315L2-2	255	385	265	3570	93.5	0.89	682	2.1	7.3	2.7	2.2	1270	96	111

**Note:**

1) Type B3 with terminal compartment type EAR

The values are also valid for series BD..

40 °C ambient temperature. winding heating within heat class F

Size	Output	Rated current at		Speed	Efficiency	Power factor	Torque	Starting torque	Starting current	Break down torque	Mass moment of inertia	Weight <sup>1)</sup>		Noise values with radial fan	
		460 V	690 V									m	L <sub>P</sub>	L <sub>W</sub>	
CD...X	P <sub>2</sub> [kW]	I [A]	I [A]	n [rpm]	η [%]	cos φ	M [Nm]	M <sub>A</sub> / M <sub>N</sub>	I <sub>A</sub> / I <sub>N</sub>	M <sub>K</sub> / M <sub>N</sub>	J [kgm <sup>2</sup> ]	m [kg]	L <sub>P</sub> [dB(A)]	L <sub>W</sub> [dB(A)]	
<b>Efficiency according to manufacturer's standard</b>															
63M1-4	0.21	0.54	0.36	1700	70	0.70	1.18	2.7	4.7	2.7	0.00046	16	48	60	
63M2-4	0.3	0.69	0.46	1645	68.5	0.80	1.74	2	3.9	2.5	0.00046	16	48	60	
71M1-4	0.43	1.04	0.69	1620	65	0.80	2.53	1.7	3.6	2.3	0.00046	16	49	61	
71M2-4	0.58	1.38	0.92	1600	67	0.79	3.46	2.1	3.6	2.7	0.00063	17	49	61	
80M1-4	0.81	1.89	1.26	1645	70	0.77	4.7	2.2	4.5	2.4	0.00092	24	50	62	
80M2-4	1.16	2.55	1.70	1655	74	0.77	6.7	2.3	4.7	2.5	0.0013	25	50	62	
90S-4	1.6	3.25	2.15	1680	75.5	0.83	9.1	2	4.9	2.5	0.0021	31	52	64	
90L-4	2.3	4.6	3.05	1670	75.5	0.83	13.2	2	4.2	2.2	0.0029	35	52	64	
100L1-4	2.9	6.2	4.15	1705	76	0.77	16.2	2.3	5.7	2.7	0.0046	44	55	67	
100L2-4	3.9	7.6	5.1	1680	78.8	0.82	22.2	2.1	5.5	2.8	0.0056	46	55	67	
112M-4	5.8	11.2	7.5	1705	81	0.80	32.5	2.6	6.4	3	0.011	59	57	69	
132S-4	7.6	13.4	8.9	1720	83.6	0.85	42	2.6	6.3	2.9	0.022	100	63	76	
132M-4	10.4	18.4	12.2	1720	85.7	0.83	58	2.7	6.3	3	0.03	110	63	76	
160M-4	15.5	27.5	18.3	1750	87.5	0.81	85	2.6	6.9	3	0.057	168	71	84	
160L-4	20	33.5	22.5	1745	88.6	0.84	109	2.5	6.8	2.9	0.079	184	71	84	
180M-4	26	45	30	1750	90	0.81	142	3.1	6.7	3.2	0.13	198	76	89	
180L-4	31	52	35	1750	91	0.82	169	3	7.2	3.1	0.155	217	76	89	
200L-4	43	69	46	1750	91	0.86	235	2.9	7.2	3	0.25	274	81	95	
225S-4	52	82	54	1760	92	0.87	282	2.6	6.1	2.6	0.4	372	84	98	
225M-4	64	101	67	1770	92.5	0.86	345	2.6	6.5	2.8	0.48	402	84	98	
250M-4	81	128	85	1770	92.5	0.86	437	2.9	7.2	3.4	0.75	573	85	99	
280S-4	105	170	114	1775	93.2	0.83	565	2.9	6.9	2.6	1.25	740	87	101	
280M-4	121	193	129	1775	93.7	0.84	651	3.1	7.4	2.8	1.48	820	87	101	
315S-4	145	230	154	1775	93.5	0.84	780	2.7	7.4	2.5	2.2	1040	89	104	
315M-4	176	275	184	1775	94	0.85	947	2.7	6.8	2.7	2.7	1120	89	104	
315L1-4	220	345	230	1780	94.3	0.85	1100	2.8	7.3	2.6	3.3	1210	89	104	
315L2-4	255	395	260	1780	94.7	0.86	1368	2.8	7.3	2.8	3.9	1430	89	104	

**Note:**

1) Type B3 with terminal compartment type EAR

The values are also valid for series BD..

# Pole-changing motors

## Mains operation 50 Hz

106

Temperature class T4,  
ns = 1500/3000 rpm, 2p = 4/2

40 °C ambient temperature. winding heating within heat class F

Size	Output	Rated current at		Speed	Efficiency	Power factor	Torque	Starting torque	Starting current	Breakdown torque	Mass moment of inertia	Weight <sup>2)</sup>		Noise values with radial fan	
		400 V	500 V									n	$\eta$	cos $\varphi$	M
CD..	P <sub>2</sub> [kW]	I [A]	I [A]	n [rpm]	$\eta$ [%]	cos $\varphi$	M [Nm]	M <sub>A</sub> / M <sub>N</sub>	I <sub>A</sub> / I <sub>N</sub>	M <sub>K</sub> / M <sub>N</sub>	J [kgm <sup>2</sup> ]	m [kg]	L <sub>P</sub> [dB(A)]	L <sub>W</sub> [dB(A)]	
80M1-4/2	0.5	1.45	1.16	1400	66.5	0.75	3.4	1.9	3.9	2.5	0.00111	24	47	59	
	0.65	1.69	1.35	2800	62.5	0.89	2.2	2.2	4.2	3			65	77	
80M2-4/2	0.7	1.92	1.54	1400	70	0.75	4.8	2.1	4	2.7	0.00148	25	47	59	
	0.85	2.15	1.71	2820	66	0.87	2.9	2.4	4.8	3.2			65	77	
90S-4/2	1.1	2.7	2.15	1390	70	0.84	7.6	1.8	4.2	2.2	0.00238	31	52	64	
	1.4	3.15	2.5	2810	70	0.92	4.8	1.9	4.9	3			69	81	
90L-4/2	1.5	3.55	2.85	1400	74	0.82	10.2	2	4.7	2.3	0.00318	35	52	64	
	1.9	4.1	3.25	2805	73	0.92	6.5	2.2	5.4	3.1			69	81	
100L-4/2	2.6	5.9	4.7	1410	78	0.82	17.6	2.2	4.8	2.7	0.00608	46	55	67	
	3.2	6.5	5.2	2870	78	0.91	10.6	2	5.8	2.8			75	87	
112M-4/2	3.7	7.6	6.1	1430	82.5	0.85	24.7	2.1	6.1	3	0.0122	59	56	68	
	4.4	8.9	7.1	2895	78.5	0.91	14.5	2.5	6.8	3.3			76	88	
132S-4/2	5	10.1	8.1	1440	85	0.84	33.2	2	5.6	2.8	0.0238	100	62	75	
	6	12.2	9.7	2905	79	0.90	19.7	2.5	6.6	3.3			80	93	
132M-4/2	7	14.1	11.3	1445	86.5	0.83	46	2.6	6.5	2.9	0.0323	110	62	75	
	9	17.5	14	2910	82.5	0.90	29.5	2.4	6.9	3.3			80	93	
160M-4/2	9.5	18.7	14.9	1455	87.5	0.84	62	2.3	6	2.8	0.0625	168	57	70	
	11	20	16	2930	87	0.91	36	2.6	6.9	3.2			68	81	
160L-4/2	13	25	20	1455	88.5	0.84	85	2.3	6	2.8	0.085	184	57	70	
	16	28.5	23	2930	87.5	0.92	52	2.6	6.9	3.2			68	81	
180M-4/2	16.5	32	25.5	1460	89.5	0.83	108	2.8	6.5	2.7	0.13	198	58	71	
	20	36.5	29.5	2930	87.5	0.90	65	2.8	7	3.1			69	82	
180L-4/2	19	36.5	29.5	1465	90	0.83	124	3.1	6.6	2.9	0.155	217	58	71	
	25	45.5	36.5	2940	88	0.90	81	2.9	7.1	3.2			69	82	
200L-4/2	26	47	37.5	1470	91.5	0.87	169	2.8	6.8	3.1	0.25	274	60	74	
	31	54	43	2955	90	0.92	100	2.7	7.2	3.5			73	87	
225S-4/2	32	59	47	1470	91.5	0.86	208	2.6	6.5	2.5	0.4	372	61	75	
	38	66	53	2950	90	0.92	123	2.6	7.2	3			74	88	
225M-4/2	38	69	55	1470	92.5	0.86	247	2.8	6.5	2.7	0.48	402	61	75	
	46	79	63	2955	91.5	0.92	149	2.8	7.2	3.2			74	88	
250M-4/2	46	82	65	1470	92.5	0.88	299	2.7	6.5	2.8	0.75	573	63	77	
	55	94	75	2955	91	0.93	178	2.9	7.1	3.3			76	90	
280S-4/2	63	116	93	1480	93	0.84	407	2.8	6.5	3	1.25	740	65	79	
	75	134	108	2970	91.5	0.88	241	2.6	7	3.1			78	92	
280M-4/2	73	131	105	1480	93.5	0.86	471	2.8	6.5	3	1.48	820	65	79	
	87	150	120	2970	92	0.91	280	2.4	7.1	3.2			78	92	
315S-4/2	85	155	124	1485	94	0.84	547	2.5	6.5	2.4	2.2	1040	67	82	
	100	174	139	2975	92.3	0.90	321	2.1	7	2.8			80	95	
315M-4/2	100	180	144	1485	94.2	0.85	643	2.6	6.6	2.4	2.7	1120	67	82	
	125	215	171	2975	92.5	0.91	401	2.3	7.1	3			80	95	
315L1-4/2	120	215	172	1485	94.8	0.85	772	2.6	6.5	2.4	3.3	1210	67	82	
	150	255	205	2975	93	0.91	482	2.3	7	2.9			80	95	
315L2-4/2	145	260	210	1485	94.8	0.85	932	2.6	6.5	2.4	3.8	1430	67	82	
	175	300	240	2975	93.2	0.91	562	2.3	7	2.9			80	95	
355S-4/2	160	280	220	1485	95.5	0.87	1029	1.3	6.4	2.4	5.1	1800	70	86	
	200	330	265	2980	94	0.93	641	1.4	6.9	2.7			82	98	
355M1-4/2	180	315	250	1485	95.5	0.87	1158	1.3	6.6	2.3	5.6	1900	70	86	
	220	365	290	2980	94	0.93	705	1.3	7.1	2.6			82	98	
355M2-4/2	200	345	280	1485	95.5	0.87	1286	1.3	6.5	2.3	6	2050	70	86	
	250	415 <sup>1)</sup>	330	2985	94	0.93	800	1.3	7	2.6			82	98	
355L-4/2	220	380	305	1485	96	0.87	1415	1.3	6.5	2.3	6.7	2200	70	86	
	280	460 <sup>1)</sup>	370	2985	94.5	0.93	896	1.3	7	2.6			82	98	

**Note:**

- 1) Two parallel supply lines are required in each case
- 2) Type B3 with terminal compartment type EAR

The values are also valid for series BD..

40 °C ambient temperature. winding heating within heat class F

Size	Output	Rated current at		Speed	Efficiency	Power factor	Torque	Starting torque	Starting current	Breakdown torque	Mass moment of inertia	Weight <sup>1)</sup>	Noise values with radial fan	
		400 V	500 V										L <sub>P</sub>	L <sub>W</sub>
CD..	P <sub>2</sub> [kW]	I [A]	I [A]	n [rpm]	η [%]	cos φ	M [Nm]	M <sub>A</sub> / M <sub>N</sub>	I <sub>A</sub> / I <sub>N</sub>	M <sub>K</sub> / M <sub>N</sub>	J [kgm <sup>2</sup> ]	m [kg]	L <sub>P</sub> [dB(A)]	L <sub>W</sub> [dB(A)]
90S-6/4	0.45	1.5	1.2	940	62	0.70	4.6	1.8	3.5	2.3	0.0038	31	52	64
	0.65	1.77	1.42	1435	68	0.78	4.3	1.7	4.2	2.5			55	67
90L-6/4	0.6	1.91	1.53	940	63	0.72	6.1	1.8	3.6	2.3	0.0051	35	52	64
	0.9	2.3	1.86	1435	71	0.80	6	1.7	4.6	2.5			55	67
100L1-6/4	0.9	2.5	1.98	945	69	0.76	9.1	1.7	3.8	2.1	0.008	44	53	65
	1.3	3.05	2.45	1450	76.5	0.80	8.6	2	5.9	2.8			57	69
100L2-6/4	1.1	3.05	2.4	940	69	0.76	11.2	1.7	3.8	2.1	0.0105	46	53	65
	1.7	3.95	3.15	1445	77.5	0.8	11.2	1.9	5.5	2.6			57	69
112M-6/4	1.5	3.6	2.9	950	74	0.81	15.1	1.8	4.6	2.2	0.019	59	54	66
	2.4	5.1	4.05	1425	76.5	0.89	16.1	1.7	4.8	2.4			59	71
132S-6/4	2.2	5.2	4.2	960	75	0.81	21.9	1.6	4.6	2.6	0.033	104	59	72
	3.3	7.1	5.7	1450	78	0.86	21.7	1.7	5.9	2.6			62	75
132M-6/4	3	7	5.6	965	76.5	0.81	29.7	1.7	5.5	2.6	0.046	112	59	72
	4.5	9.2	7.4	1455	80	0.88	29.5	1.8	6.3	2.7			62	75
160M-6/4	4.5	10	8	970	80.5	0.81	44.3	2.1	6.4	2.9	0.095	170	64	77
	6.6	12.8	10.2	1445	82	0.91	43.6	1.8	6.3	2.7			70	83
160L-6/4	6.5	13.2	10.5	960	81	0.88	65	1.6	5.5	2.5	0.13	190	64	77
	9.5	18.1	14.5	1465	85	0.89	62	1.9	6.9	3			70	83
180L-6/4	11	23.5	18.9	975	85	0.79	108	2.4	6.9	3.2	0.155	215	56	69
	16	29.5	23.5	1465	87	0.90	104	1.8	6.6	2.8			63	76
200L-6/4	16	32.5	26	975	86.5	0.82	155	2	6.6	2.9	0.338	280	56	70
	24	43.5	35	1470	89	0.89	156	1.8	6.9	2.9			63	77
225S-6/4	21	40	32	975	89	0.85	206	2.8	6.5	2.8	0.4	372	60	74
	31	54	43	1470	90	0.92	201	2.2	6.7	2.9			67	81
225M-6/4	25	47	37.5	975	89.5	0.86	245	2.9	6.7	2.9	0.48	404	60	74
	37	64	51	1470	91	0.92	240	2.4	6.9	3			67	81
250M-6/4	32	59	47	975	90	0.87	313	2.9	6.9	2.8	0.75	570	61	75
	47	81	65	1475	91	0.92	304	2.4	7.1	2.9			68	82
280S-6/4	45	89	71	980	91	0.8	439	2.9	6.3	2.8	1.02	740	62	76
	66	118	86	1480	92.5	0.87	426	2.7	7.1	3.1			70	84
280M-6/4	54	107	86	980	91	0.80	526	3.2	6.7	3	1.27	820	62	76
	80	142	113	1475	92.5	0.88	518	2.6	7	3			70	84
315S-6/4	60	114	91	985	92.5	0.82	582	2.4	6.6	2.3	2.2	996	63	78
	85	147	118	1480	93.5	0.89	547	2.5	6.9	2.5			71	86
315M-6/4	70	134	107	985	93	0.81	679	2.5	6.7	2.4	2.7	1096	63	78
	100	173	138	1480	94	0.89	643	2.6	6.9	2.5			71	86
315L1-6/4	85	161	129	985	93	0.82	824	2.6	6.8	2.5	3.3	1221	63	78
	120	205	164	1480	94	0.90	772	2.7	7	2.6			71	86
315L2-6/4	100	182	145	985	93.5	0.85	970	2.6	6.8	2.5	3.9	1290	63	78
	140	235	189	1485	95	0.90	900	2.7	7	2.6			71	86
355S-6/4	110	192	154	985	94	0.88	1067	1.7	6.8	2.4	8.9	1750	83	83
	160	265	215	1485	95	0.91	1029	1.6	6.8	2.3			92	92
355M-6/4	130	225	181	985	94	0.88	1260	1.7	6.8	2.3	10.9	1950	83	83
	180	300	240	1485	95	0.91	1152	1.6	7	2.2			92	92
355L-6/4	150	260	210	990	94.5	0.88	1454	1.6	6.9	2.3	12.6	2200	83	83
	210	350	280	1485	95	0.91	1351	1.6	6.9	2.3			92	92

Note:

<sup>1)</sup> Type B3 with terminal compartment type EAR

The values are also valid for series BD..

# Pole-changing motors

## Mains operation 50 Hz

Temperature class T4,  
ns = 750/1500 rpm, 2p = 8/4

108

40 °C ambient temperature. winding heating within heat class F

Size	Output	Rated current at		Speed	Efficiency	Power factor	Torque	Starting torque	Starting current	Breakdown torque	Mass moment of inertia	Weight <sup>1)</sup>	Noise values with radial fan	
		400 V	500 V										L <sub>P</sub>	L <sub>W</sub>
CD..	P <sub>2</sub> [kW]	I [A]	I [A]	n [rpm]	η [%]	cos φ	M [Nm]	M <sub>A</sub> / M <sub>N</sub>	I <sub>A</sub> / I <sub>N</sub>	M <sub>K</sub> / M <sub>N</sub>	J [kgm <sup>2</sup> ]	m [kg]	L <sub>P</sub> [dB(A)]	L <sub>W</sub> [dB(A)]
90S-8/4	0.4	1.62	1.3	695	57.5	0.62	5.5	1.6	2.9	2	0.0038	31	49	61
	0.6	1.46	1.17	1395	69	0.86	4.1	1.6	4.2	2.3			52	64
90L-8/4	0.55	2.1	1.68	700	60	0.63	7.5	1.6	3.3	2.2	0.0051	35	49	61
	0.8	1.84	1.47	1410	72	0.87	5.4	1.8	4.6	2.6			52	64
100L1-8/4	0.9	3.05	2.45	690	60	0.71	12.5	1.6	3.2	2.1	0.008	44	52	64
	1.3	3	2.45	1385	69.5	0.89	8.9	1.6	4.2	2.2			55	67
100L2-8/4	1	3.1	2.5	700	65	0.71	13.6	1.7	3.7	2.2	0.011	46	52	64
	1.6	3.6	2.9	1395	71	0.9	11	1.7	4.5	2.4			55	67
112M-8/4	1.5	4.6	3.7	710	72.5	0.65	20.2	2	4.4	2.2	0.019	59	52	64
	2.5	5.1	4.1	1410	78	0.90	16.9	1.9	5.2	2.3			56	68
132S-8/4	2.3	6.8	5.4	720	75	0.65	30.5	1.8	4.4	2.6	0.0325	97	53	66
	3.6	7.2	5.8	1440	81	0.89	23.8	1.8	5.8	2.5			62	75
132M-8/4	3	8.4	6.7	720	78	0.66	40	2	4.6	2.7	0.046	113	53	66
	5	9.7	7.8	1440	82.5	0.90	33	1.9	5.8	2.6			62	75
160M1-8/4	4.7	11.5	9.2	720	81	0.73	62	1.7	4.8	2.5	0.081	157	54	67
	5.5	12.2	9.8	1445	76.5	0.85	36.3	2.1	5.7	3			66	79
160M2-8/4	5.5	12.3	9.8	715	83	0.78	73	1.7	4.6	2.2	0.108	170	54	67
	7.5	14.8	11.9	1440	81	0.90	50	2	6.1	2.8			66	79
160L-8/4	7	16.3	13	720	84	0.74	93	2	5.5	2.7	0.145	190	54	67
	11	22	17.5	1445	81.5	0.89	73	2	6.6	3			66	79
180L-8/4	11	25	20	725	86.5	0.73	145	2	6	2.8	0.243	215	53	66
	18	32	25.5	1460	88.5	0.92	118	2	6.9	3.1			63	76
200L-8/4	17	41	33	730	88	0.68	222	2.2	6.4	3.5	0.438	280	53	67
	27	47	37.5	1470	91	0.91	175	2	7.3	3.6			63	77
225S-8/4	22	48.5	39	730	88.5	0.74	288	2.3	6.4	3.3	0.625	372	56	70
	32	56	45	1470	90.5	0.91	208	2.1	7.3	3.5			67	81
225M-8/4	26	53	43	730	90	0.78	340	2.4	6.5	3.4	0.75	404	56	70
	38	65	52	1470	91	0.91	247	2.2	7.3	3.6			67	81
250M-8/4	32	65	52	735	90.8	0.78	416	1.9	6.8	2.9	1.28	570	55	69
	47	80	64	1480	92	0.92	303	2	7.4	3.3			68	82
280S-8/4	42	85	68	735	91.5	0.78	546	2.1	6.4	2.5	2	740	58	72
	60	101	81	1475	92.5	0.93	388	2.1	7.2	3.1			70	84
280M-8/4	50	98	78	735	92	0.80	650	2.1	6.5	2.4	2.4	810	58	72
	72	120	96	1475	93	0.93	466	2	7.2	3			70	84
315S-8/4	60	114	91	740	92.5	0.82	774	2.6	6.5	2.5	4.4	996	67	82
	90	150	120	1480	93	0.93	581	2.5	7	2.6			79	94
315M-8/4	75	143	114	740	92.5	0.82	968	2.6	6.3	2.5	5.4	1096	67	82
	110	184	147	1480	93	0.93	710	2.5	7.1	2.7			79	94
315L1-8/4	90	170	136	740	93	0.82	1161	2.7	6.6	2.6	6.6	1221	67	82
	132	220	175	1480	93.5	0.93	852	2.5	7.1	2.9			79	94
315L2-8/4	115	215	173	740	92.5	0.83	1484	2.6	6.6	2.5	8	1320	67	82
	160	265	215	1480	93	0.93	1032	2.6	7.1	3			79	94
355M-8/4	120	230	185	745	94	0.8	1538	1.3	6.6	2.4	8.9	1750	69	85
	175	320	255	1485	94.5	0.93	1125	1.5	7.3	2.5			76	92
355L1-8/4	140	265	215	745	95	0.80	1795	1.4	6.9	2.5	10.9	1950	69	85
	215	345	275	1490	95.3	0.95	1378	1.6	7.6	2.3			76	92
355L2-8/4	165	315	250	745	95	0.80	2115	1.3	6.8	2.4	12.6	2200	69	85
	250	400	320	1490	95.5	0.94	1602	1.5	7.6	2.4			76	92

**Note:**

<sup>1)</sup> Type B3 with terminal compartment type EAR

The values are also valid for series BD..

40 °C ambient temperature. winding heating within heat class F

Size	2p = 4/2 1500/3000 rpm Output P <sub>2</sub> [kW]		Size	2p = 6/4 1000/1500 rpm Output P <sub>2</sub> [kW]		Size	2p = 8/4 750/1500 rpm Output P <sub>2</sub> [kW]	
CD...			CD...			CD...		
80M1	0.17	0.65	-	-	-	-	-	-
80M2	0.25	0.85	-	-	-	-	-	-
90S	0.37	1.4	90S	0.3	1	90S	0.13	0.6
90L	0.5	1.9	90L	0.4	1.3	90L	0.18	0.8
100L	0.85	3.2	100L1	0.6	1.8	100L1	0.3	1.3
-	-	-	100L2	0.75	2.4	100L1	0.33	1.6
112M	1.2	4.4	112M	0.9	3	112M	0.5	2.5
132S	1.7	6	132S	1.3	4.3	132S	0.75	3.6
132M	2.3	9	132M	1.8	5.5	132M	1	5
160M	3.1	11	160M	3	9	160M1	1.6	5.5
160L	4.3	16	160L	3.5	12	160M2	1.8	7.5
-	-	-	-	-	-	160L	2.3	11
180M	5.5	20	-	-	-	-	-	-
180L	6.3	25	180L	6.5	19	180L	3.7	18
200L	8.7	31	200L	9.5	26	200L	5.7	27
225S	11	38	225S	12	34	225S	7.3	32
225M	13	46	225M	14.5	40	225M	8.7	38
250M	15	55	250M	18	52	250M	11	47
280S	21	75	280S	25	70	280S	14	60
280M	24	87	280M	30	82	280M	17	72
315S	28	100	315S	32	95	315S	20	90
315M	33	125	315M	37	115	315M	25	110
315L1	40	150	315L1	47	135	315L1	30	132
315L2	48	175	315L2	55	160	315L2	38	160
355S	53	200	355S	60	185	-	-	-
355M1	60	220	355M	70	200	355M	40	175
355M2	67	250	355L	80	230	355L1	47	215
355L	73	280	-	-	-	355L2	55	250

The values are also valid for series BD..

# Pole-changing motors

## Mains operation 60 Hz

110

Temperature class T4

40 °C ambient temperature. winding heating within heat class F

Size	2p = 4/2 1800/3600 rpm		Size	2p = 6/4 1200/1800 rpm		Size	2p = 8/4 900/1800 rpm	
	Output P <sub>2</sub> [kW]	CD..		Output P <sub>2</sub> [kW]	CD...		Output P <sub>2</sub> [kW]	CD...
80M1	0.58	0.75	-	-	-	-	-	-
80M2	0.81	1	-	-	-	-	-	-
90S	1.3	1.6	90S	0.52	0.75	90S	0.46	0.7
90L	1.7	2.2	90L	0.7	1.05	90L	0.64	0.93
100L	3	3.7	100L1	1.05	1.5	100L1	1.05	1.5
-	-	-	100L2	1.3	2	100L1	1.15	1.9
112M	4.3	5	112M	1.7	2.8	112M	1.8	2.9
132S	5.8	7	132S	2.5	3.8	132S	2.7	4.2
132M	8	10.5	132M	3.5	5.2	132M	3.5	5.8
160M	11	12.7	160M	5.2	8	160M1	5.4	6.4
160L	15	18.5	160L	7.5	11	160M2	6.4	8.7
-	-	-	-	-	-	160L	8.1	12.7
180M	19	23	-	-	-	-	-	-
180L	22	29	180L	12.7	18.5	180L	12.7	21
200L	30	36	200L	18.5	28	200L	20	31
225S	37	44	225S	24	36	225S	25	36
225M	44	53	225M	29	43	225M	30	44
250M	53	64	250M	37	54	250M	37	54
280S	73	87	280S	52	76	280S	49	69
280M	85	100	280M	63	93	280M	58	83
315S	94	110	315S	70	98	315S	69	104
315M	110	138	315M	81	110	315M	87	121
315L1	132	165	315L1	98	132	315L1	104	145
315L2	160	193	315L2	110	154	315L2	127	176
355S	176	220	355S	121	176	-	-	-
355M1	198	240	355M	143	198	355M	123	193
355M2	220	275	355L	165	230	355L1	154	235
355L	240	310	-	-	-	355L2	182	275

The values are also valid for series BD..

40 °C ambient temperature. winding heating within heat class F

Size	2p = 4/2 1800/3600 rpm		Size	2p = 6/4 1200/1800 rpm		Size	2p = 8/4 900/1800 rpm	
CD..	Output P <sub>2</sub> [kW]		CD...	Output P <sub>2</sub> [kW]		CD...	Output P <sub>2</sub> [kW]	
80M1	0.19	0.75	-	-	-	-	-	-
80M2	0.27	1	-	-	-	-	-	-
90S	0.43	1.6	90S	0.35	1.15	90S	0.15	0.7
90L	0.57	2.2	90L	0.46	1.5	90L	0.21	0.93
100L	1	3.7	100L1	0.7	2.1	100L1	0.35	1.5
-	-	-	100L2	0.87	2.8	100L1	0.38	1.9
112M	1.4	5	112M	1.05	3.5	112M	0.6	2.9
132S	1.9	7	132S	1.5	5	132S	0.9	4.2
132M	2.7	10.5	132M	2.1	6.4	132M	1.15	5.8
160M	3.7	12.7	160M	3.5	10.5	160M1	1.8	6.4
160L	5	18.5	160L	4.1	14	160M2	2.1	8.7
-	-	-	-	-	-	160L	2.7	12.7
180M	6.3	23	-	-	-	-	-	-
180L	7.3	29	180L	7.5	22	180L	4.2	21
200L	10	36	200L	11	30	200L	6.7	31
225S	12	44	225S	14	39	225S	8.3	36
225M	15	53	225M	17	46	225M	10	44
250M	18	64	250M	21	60	250M	12	54
280S	24	87	280S	29	81	280S	16	69
280M	28	100	280M	35	95	280M	19	83
315S	31	110	315S	37	110	315S	23	104
315M	37	138	315M	43	127	315M	29	121
315L1	44	165	315L1	54	149	315L1	35	145
315L2	53	193	315L2	64	176	315L2	42	176
355S	59	220	355S	69	205	-	-	-
355M1	66	240	355M	81	220	355M	44	193
355M2	73	275	355L	93	255	355L1	51	235
355L	80	310	-	-	-	355L2	61	275

The values are also valid for series BD..

# Motors with built-in brake

## Mains operation 50 Hz

Temperature class T4,  
2p = 2, 4, 6, 8

112

Size	Output	Rated current at		Speed	Efficiency	Power factor	Starting torque	Starting current	Motor torque	Brake-torque <sup>1)</sup>		Mass moment of inertia	Weight <sup>2)</sup>	Permissible switching operations per hour with operating mode S4			
		400V	500V							type				FI = 1.5	FI = 2	FI = 3	FI = 4
BD...B	P <sub>2</sub> [kW]	I [A]	I [A]	n [rpm]	η [%]	cos φ	M <sub>A</sub> / M <sub>N</sub>	I <sub>A</sub> / I <sub>N</sub>	M [Nm]	M <sub>e</sub> [Nm]	J [kgm <sup>2</sup> ]	m [kg]	[S/h]	[S/h]	[S/h]	[S/h]	
<b>Efficiency according to manufacturer's standard</b>																	
<b>n<sub>s</sub> = 3000 rpm 2p = 2</b>																	
80M1-2	0.75	1.73	1.38	2790	74.5	0.84	2.7	4.8	2.57	20	M16	0.0028	37	111 0	935	710	570
80M2-2	1.1	2.5	1.99	2820	78	0.82	2.8	5.5	3.73	20	M16	0.0031	41	580	495	435	320
90S-2	1.5	3.25	2.6	2840	77	0.86	2.9	5.9	5	46	M32	0.0052	53	130	115	90	80
90L-2	2.2	4.55	3.65	2850	82	0.85	3	6.3	7.4	46	M32	0.0059	56	184	165	135	115
100L-2	3	6.1	4.85	2850	82	0.87	2.7	6.8	10.1	46	M32	0.0057	63	71	65	54	47
112M-2	4	7.7	6.2	2880	85	0.88	2.3	6.5	13.3	86	M60	0.0112	105	140	120	95	75
132S1-2	5.5	10.7	8.5	2880	85.5	0.87	2.5	6.4	18.2	86	M60	0.0151	120	53	46	37	30
132S2-2	7.5	14.4	11.5	2910	86.5	0.87	2.7	6.8	24.7	86	M60	0.0197	132	70	60	45	40
<b>Efficiency according to manufacturer's standard</b>																	
<b>n<sub>s</sub> = 1500 rpm 2p = 4</b>																	
80M1-4	0.55	1.38	1.1	1380	72	0.8	2	3.8	3.8	20	M16	0.0037	30	134 0	1185	960	800
80M2-4	0.75	1.81	1.45	1400	75.5	0.79	2.1	4.5	5.1	20	M16	0.0043	41	134 0	1170	930	640
90S-4	1.1	2.55	2.05	1400	76	0.83	2.1	4.8	7.5	46	M32	0.0068	52	230	205	170	145
90L-4	1.5	3.35	2.65	1405	79	0.82	2.3	5	10.2	46	M32	0.0079	54	270	245	200	170
100L1-4	2.2	4.95	3.95	1420	80	0.8	2.4	5.4	14.8	46	M32	0.0119	69	235	215	185	165
100L2-4	3	6.5	5.2	1415	81.7	0.82	2.3	5.5	20.2	46	M32	0.0119	69	110	105	90	80
112M-4	4	8.1	6.5	1435	85	0.84	2.7	6.8	26.5	86	M60	0.0233	110	220	210	180	160
132S-4	5.5	10.8	8.6	1440	86.5	0.85	2.5	6.4	36.5	86	M60	0.0317	130	100	95	75	65
132M-4	7.5	14.3	11.4	1440	88	0.86	2.7	6.5	50	86	M60	0.0417	142	100	90	75	65
<b>Efficiency according to manufacturer's standard</b>																	
<b>n<sub>s</sub> = 1000 rpm 2p = 6</b>																	
80M1-6	0.37	1.12	0.9	925	67	0.71	2.5	4.1	3.8	20	M16	0.005	30	112 0	950	725	590
80M2-6	0.55	1.6	1.28	925	69	0.72	2.4	4	5.7	20	M16	0.006	31	114 5	980	765	620
90S-6	0.75	2.15	1.72	910	70.2	0.75	1.8	3.4	7.9	46	M32	0.0097	52	675	605	500	425
90L-6	1.1	3.05	2.45	920	73	0.73	2	3.7	11.4	46	M32	0.0119	54	125	115	100	85
100L-6	1.5	3.75	3	945	77	0.75	2.5	4.9	15.2	46	M32	0.0181	69	240	215	175	145
112M-6	2.2	5.2	4.2	950	81	0.75	2.7	5.6	22.1	86	M60	0.0308	110	595	530	425	355
132S-6	3	6.6	5.3	965	84	0.78	2.7	6.3	29.7	86	M60	0.0321	117	390	350	290	250
132M1-6	4	8.6	6.9	960	85	0.79	2.6	6	39.6	86	M60	0.0376	121	215	195	160	140
132M2-6	5.5	11.4	9.1	960	86	0.81	2.6	6.4	55	86	M60	0.0489	134	125	110	95	80
<b>Efficiency according to manufacturer's standard</b>																	
<b>n<sub>s</sub> = 750 rpm 2p = 8</b>																	
80M1-8	0.18	0.74	0.59	690	54	0.65	2.2	3.2	2.5	20	M16	0.005	30	112 5	940	710	580
80M2-8	0.25	0.96	0.77	690	58.5	0.64	2.2	3.2	3.5	20	M16	0.006	31	112 5	940	710	580
90S-8	0.37	1.36	1.10	690	60	0.65	1.8	3	5.1	46	M32	0.0097	39	128 5	1090	920	780
90L-8	0.55	1.94	1.55	690	63	0.65	1.8	3.1	7.6	46	M32	0.0119	43	116 0	980	830	690
100L1-8	0.75	2.45	1.96	710	67	0.66	2.4	4	10.1	46	M32	0.0119	69	970	820	690	570
100L2-8	1.1	3.15	2.5	695	69	0.73	2	3.8	15.1	46	M32	0.0181	69	880	750	630	520
112M-8	1.5	4.15	3.3	710	76	0.67	2.2	4.6	20.2	86	M60	0.0293	107	680	560	480	406
132S-8	2.2	5.2	4.2	695	77	0.79	2	4.1	30	86	M60	0.0306	114	650	550	460	380
132M-8	3	7	5.6	705	80.5	0.77	2.4	4.6	41	86	M60	0.0399	130	630	520	450	360

### Note

<sup>1)</sup> Tolerance -20%/+40% at 1 m/s friction speed

<sup>2)</sup> Type B3 with terminal compartment type EAR

# Motors with built-in brake Mains operation 50 Hz

Temperature class T4,  
2p = 2, 4, 6, 8

113

Size	Output	Rated current at		Speed	Efficiency	Power factor	Starting torque	Starting current	Motor torque	Brake-torque <sup>1)</sup>	type	Mass moment of inertia	Weight <sup>2)</sup>	Permissible switching operations per hour with operating mode S4 15. 20. 40 or 60% ED			
		400V	500V											FI = 1.5	FI = 2	FI = 3	FI = 4
BD...Y3B	P <sub>2</sub> [kW]	I [A]	I [A]	n [rpm]	η [%]	cos φ	M <sub>A</sub> / M <sub>N</sub>	I <sub>A</sub> / I <sub>N</sub>	M [Nm]	M <sub>e</sub> [Nm]	J [kgm <sup>2</sup> ]	m [kg]	FI = 1.5 [S/h]	FI = 2 [S/h]	FI = 3 [S/h]	FI = 4 [S/h]	
<b>n<sub>s</sub> = 3000 rpm 2p = 2</b>																	
					<b>IE3</b>	Efficiency according to IEC 60034-30											
80M1-2	0.75	1.5	1.20	2890	82.8	0.87	3	6.6	2.48				by request	1110	935	710	570
80M2-2	1.1	2.2	1.74	2885	83.7	0.87	3.2	7.1	3.64				by request	580	495	435	320
90S-2	1.5	2.9	2.3	2895	84.7	0.88	3	6.8	4.95				by request	130	115	90	80
90L-2	2.2	4.2	3.35	2900	86.4	0.88	3	6.9	7.2				by request	184	165	135	115
100L-2	3	5.6	4.45	2910	88.1	0.88	2.5	6.9	9.8				by request	71	65	54	47
112M-2	4	7.5	6	2930	88.4	0.87	2.8	6.9	13				by request	140	120	95	75
132S1-2	5.5	10	8	2925	89.5	0.89	2.5	7	18				by request	53	46	37	30
132S1-2	7.5	13.5	10.78	2930	90.3	0.89	2.7	7.1	24.4				by request	70	60	45	40
<b>n<sub>s</sub> = 1500 rpm 2p = 4</b>																	
					<b>IE3</b>	Efficiency according to IEC 60034-30											
80M1-4	0.55	1.24	0.99	1440	81	0.79	2.9	6.8	3.65				by request	1340	1185	960	800
80M2-4	0.75	1.68	1.344	1445	82.6	0.78	3.2	6.8	5				by request	1340	1170	930	640
90S-4	1.1	2.35	1.886	1455	84.2	0.8	2.4	6.8	7.2				by request	230	205	170	145
90L-4	1.5	3.15	2.501	1450	85.5	0.81	2.5	6.9	9.9				by request	270	245	200	170
100L1-4	2.2	4.35	3.45	1450	87.1	0.84	2.9	7.3	14.5				by request	235	215	185	165
100L2-4	3	5.9	4.697	1450	87.8	0.84	3.1	7.4	18.8				by request	110	105	90	80
112M-4	4	7.8	6.3	1460	88.7	0.83	3	7.2	26.2				by request	220	210	180	160
132S-4	5.5	10.42	8.3	1460	89.6	0.85	3.2	7.1	36				by request	100	95	75	65
132M-4	7.5	13.90	11.13	1460	90.5	0.86	3.1	7.4	49				by request	100	90	75	65
<b>n<sub>s</sub> = 1000 rpm 2p = 6</b>																	
					<b>IE3</b>	Efficiency according to IEC 60034-30											
80M1-6	0.37	1.02	0.82	950	73.8	0.71	1.7	4.4	3.70				by request	1120	950	725	590
80M2-6	0.55	1.41	1.12	945	77.4	0.73	1.8	4.5	5.3				by request	1145	980	765	620
90S-6	0.75	1.955	1.56	955	79.1	0.70	2.7	5.5	7.5				by request	675	605	500	425
90L-6	1.1	2.7	2.15	955	81.4	0.72	2.8	5.9	11				by request	125	115	100	85
100L-6	1.5	3.652	2.9	965	83.5	0.71	3	6.8	14.8				by request	240	215	175	145
112M-6	2.2	4.75	3.8	965	85.5	0.78	2.6	6.8	21.8				by request	595	530	425	355
132S-6	3	6.8	5.5	970	85.7	0.74	3.2	7.1	29.5				by request	390	350	290	250
132M1-6	4	8.7	7	965	87	0.76	2.9	6.9	39.6				by request	215	195	160	140
132M2-6	5.5	11.53	9.2	965	88.3	0.78	2.9	7.2	54				by request	125	110	95	80
<b>n<sub>s</sub> = 750 rpm 2p = 8</b>																	
					<b>IE3</b>	Efficiency according to IEC 60034-30											
80M1-8	0.18	0.71	0.57	705	63	0.58	1.9	3.2	2.43				by request	1125	940	710	580
80M2-8	0.25	0.90	0.72	710	67	0.60	1.7	3.3	3.35				by request	1125	940	710	580
90S-8	0.37	1.16	0.93	715	72	0.64	1.7	4.4	4.95				by request	1285	1090	920	780
90L-8	0.55	1.68	1.34	715	74	0.64	1.8	4.5	7.3				by request	1160	980	830	690
100L1-8	0.75	2.25	1.80	720	76	0.64	2.3	5	9.9				by request	970	820	690	570
100L2-8	1.1	3.1	2.5	715	78	0.67	2.2	4.8	14.7				by request	880	750	630	520
112M-8	1.5	3.5	2.8	705	80.6	0.77	2	4.9	20.3				by request	680	560	480	406
132S-8	2.2	5.4	4.3	710	82	0.72	2.8	6.3	29.6				by request	650	550	460	380
132M-8	3	7.2	5.8	715	83.5	0.72	2.7	6.3	40				by request	630	520	450	360

## Note

- <sup>1)</sup> Tolerance -20%/+40% at 1 m/s friction speed  
<sup>2)</sup> Type B3 with terminal compartment type EAR

# Motors with mounted brake

## Mains operation 50 Hz

114

Temperature class T4,  
2p = 8/4, 8/2

Size	Output	Rated current at		Speed	Efficiency	Power factor	Starting torque	Starting current	Motor torque	Brake		Mass-moment of inertia	Weight <sup>2)</sup>	Permissible switching operations per hour with operating mode S4 15. 20. 40 or 60% ED			
		400V	500V							torque <sup>1)</sup>	type			Fl = 1.5	Fl = 2	Fl = 3	Fl = 4
BD...B	P <sub>2</sub>	I	I	n	η	cos φ	M <sub>A</sub> / M <sub>N</sub>	I <sub>A</sub> / I <sub>N</sub>	M	M <sub>b</sub>	J	m	[S/h]	[S/h]	[S/h]	[S/h]	
n <sub>s</sub> = 750/1500 rpm 2p = 8/4																	
90S-8/4	0.4	1.62	1.3	695	57.5	0.62	1.6	2.9	5.5	20	M 16	0.0049	38	by request			
	0.6	1.46	1.17	1395	69	0.86	1.6	4.2	4.1								
90L-8/4	0.55	2.1	1.68	700	60	0.63	1.6	3.3	7.5	20	M 16	0.0069	42				
	0.8	1.84	1.47	1410	72	0.87	1.8	4.6	5.4								
100L1-8/4	0.9	3.05	2.45	690	60	0.71	1.6	3.2	12.5	46	M 32	0.0098	51	by request			
	1.3	3	2.45	1385	69.5	0.89	1.5	4.2	9								
100L2-8/4	1	3.1	2.5	700	65	0.71	1.7	3.7	13.6	46	M 32	0.0138	54				
	1.6	3.6	2.9	1395	71	0.9	1.6	4.5	11								
112M-8/4	1.5	4.6	3.7	710	72.5	0.65	2	4.4	20.2	46	M 32	0.0218	69	by request			
	2.5	5.1	4.1	1410	78	0.9	1.9	5.2	16.9								
132S-8/4	2.3	6.8	5.4	720	75	0.65	1.8	4.4	30.5	86	M 60	0.0353	127	by request			
	3.6	7.2	5.8	1440	81	0.89	1.8	5.8	23.8								
132M-8/4	3	8.5	6.7	720	78	0.66	2	4.6	40	86	M 60	0.0498	138				
	5	9.7	7.8	1440	82.5	0.9	1.9	5.8	33								
n <sub>s</sub> = 750/3000 rpm 2p = 8/2																	
80M1-8/2	0.1	0.5	0.4	685	46.5	0.62	1.5	2.3	1.39	10	M 8	0.0015	26	by request			
	0.4	1.07	0.86	2870	62.5	0.86	2.3	5.5	1.33								
80M2-8/2	0.14	0.69	0.55	685	47	0.62	1.4	2.5	1.95	10	M 8	0.0019	27				
	0.56	1.51	1.21	2870	63	0.85	2	6	1.86								
90S-8/2	0.2	0.95	0.76	710	49	0.62	1.9	2.3	2.7	20	M 16	0.0035	38	by request			
	0.8	2	1.61	2885	63	0.91	2.3	5.5	2.65								
90L-8/2	0.3	1.37	1.1	710	51	0.62	1.7	2.8	4	20	M 16	0.0058	42				
	1.1	2.55	2.05	2885	68	0.91	2.1	6.2	3.6								
100L1-8/2	0.33	1.42	1.14	715	54	0.62	1.9	3	4.4	46	M32	0.0069	51	by request			
	1.3	2.85	2.25	2885	72	0.92	1.8	6	4.3								
100L2-8/2	0.4	1.68	1.34	715	55.5	0.62	1.9	3.3	5.3	46	M 32	0.007	54				
	1.5	3.2	2.55	2890	73.5	0.92	1.8	6.1	5								
112M-8/2	0.55	2.15	1.72	715	59.5	0.62	1.6	3.2	7.3	46	M 32	0.011	69	by request			
	2.2	4.4	3.5	2930	78.5	0.92	2.5	7.2	7.2								
132S-8/2	0.8	2.95	2.35	720	60	0.65	1.7	3.2	10.6	86	M 60	0.0286	127	by request			
	3.2	6.6	5.3	2925	76.5	0.92	2.5	7.2	10.4								
132M-8/2	1.1	3.8	3.05	725	65	0.64	2.1	3.5	14.5	86	M 60	0.037	138				
	4.2	8.1	6.5	2935	80.5	0.93	2.6	7.2	13.7								

**Note:**

<sup>1)</sup> Tolerance -20%/+40% at 1 m/s friction speed

<sup>2)</sup> Type B3 with terminal compartment type EAR

# Motors with mounted brake

## Mains operation 50 Hz

Temperature class T4,  
Type CD...SM and ...SMN

115

Size	Output	Motor torque	Braking torque	Brake type CM/CM...N	Mass moment of inertia of brake	Brake weight	Total weight	
							CD...SM <sup>1)</sup>	CD...SMN <sup>1)</sup>
CD ... SM CD ... SMN	P <sub>2</sub> [kW]	M [Nm]	M <sub>B</sub> [Nm]		J <sub>B</sub> [kgm <sup>2</sup> ]	m [kg]	m [kg]	m [kg]
<b>ns = 3000 rpm. 2p = 2</b>								
71M1-2	0.37	1.26	5	71	-	-	-	-
71M2-2	0.55	1.87	5	71	-	-	-	-
80M1-2	0.75	2.57	16	80	0.00033	31	55	57
80M2-2	1.1	3.73	16	80	0.00033	31	56	58
90S-2	1.5	5	20	90	0.00033	31	63	64
90L-2	2.2	7.4	20	90	0.00033	31	66	67
100L-2	3	10.1	50	112	0.00133	43	86	88
112M-2	4	13.3	50	112	0.00133	43	95	99
132S1-2	5.5	18.2	100	132	0.003	67	165	174
132S2-2	7.5	24.6	100	132	0.003	67	172	181
160M1-2	11	36	150	160	0.0057	100	270	278
160M2-2	15	49	150	160	0.0057	100	285	293
160L-2	18.5	60	150	160	0.0057	100	295	303
<b>ns = 1500 rpm. 2p = 4</b>								
71M1-4	0.25	1.74	5	71	-	-	-	-
71M2-4	0.37	2.56	5	71	-	-	-	-
80M1-4	0.55	3.8	16	80	0.00033	31	54	56
80M2-4	0.75	5.1	16	80	0.00033	31	56	58
90S-4	1.1	7.5	20	90	0.00033	31	63	64
90L-4	1.5	10.2	20	90	0.00033	31	65	66
100L1-4	2.2	14.8	50	112	0.00133	43	86	88
100L2-4	3	20.2	50	112	0.00133	43	89	91
112M-4	4	26.6	50	112	0.00133	43	99	103
132S-4	5.5	36.5	100	132	0.003	67	172	181
132M-4	7.5	50	100	132	0.003	67	181	190
160M-4	11	72	150	160	0.0057	100	277	285
160L-4	15	98	150	160	0.0057	100	293	301

**Note:**

<sup>1)</sup> Type B3 with terminal compartment type EAR and brake

Size	Output	Motor torque	Braking torque	Brake type	Mass moment of inertia of brake	Total weight <sup>1)</sup>
	P <sub>2</sub> [kW]	M [Nm]	M <sub>B</sub> [Nm]		J <sub>B</sub> [kgm <sup>2</sup> ]	m [kg]
<b>ns = 3000 rpm. 2p = 2</b>						
<b>180 M-2</b>	22	72	150	19	0.0125	310
<b>200L1-2</b>	30	97	270	24	0.0125	360
<b>200L2-2</b>	37	120	270	24	0.0125	385
<b>ns = 1500 rpm 2p = 4</b>						
<b>180M-4</b>	18.5	121	150	19	0.0125	295
<b>180L-4</b>	22	144	270	24	0.0125	310
<b>200L-4</b>	30	196	270	24	0.0125	380

Size	Output	Motor torque	Braking torque	Brake type	Total weight <sup>1)</sup>
CD ...SV	P <sub>2</sub> [kW]	M [Nm]	M <sub>B</sub> [Nm]		m [kg]
<b>ns = 3000 rpm 2p = 2</b>					
<b>180M-2*</b>	22	72	250	180	331
<b>200L1-2*</b>	30	97	390	200	404
<b>200L2-2*</b>	37	120	390	200	428
<b>ns = 1500 rpm 2p = 4</b>					
<b>180M-4</b>	18.5	121	250	180	333
<b>180L-4</b>	22	144	250	180	352
<b>200L-4</b>	30	196	390	200	424
<b>225S-4</b>	37	241	390	225	547
<b>225M-4</b>	45	292	390	225	577
<b>250M-4</b>	55	357	900	250	838
Size	Output	Motor torque	Braking torque	Brake type	Total weight <sup>1)</sup>
CD...SVN	P <sub>2</sub> [kW]	M [Nm]	M <sub>B</sub> [Nm]		m [kg]
<b>ns = 1500 rpm 2p = 4</b>					
<b>180 M-2*</b>	22	72	150	350	320
<b>200L1-2*</b>	30	97	270	350	370
<b>200L2-2*</b>	37	120	270	350	390
<b>ns = 1500 rpm 2p = 4</b>					
<b>180M-4</b>	18.5	121	180-350	350	305
<b>180L-4</b>	22	144	180-350	350	320
<b>200L-4</b>	30	196	180-350	350	390
<b>225S-4</b>	37	241	350-750	750	625
<b>225M-4</b>	45	292	350-750	750	655
<b>250M-4</b>	55	357	350-750	750	810
<b>280S-4</b>	75	484	350-750	750	1020
<b>280M-4</b>	90	579	350-750	750	1090

\* only S3 40 %

**Note:**

<sup>1)</sup> Type B3 with terminal compartment type EAR and brake  
Number of poles 6 and 8 by request.

### Built-in brakes type ...YB

Size Motor	Voltage U = [Nm]	Current I = [A]	Resistance R <sub>min</sub> [Ω]	Voltage U ~ [V]	Current I ~ [A]
80	24	1.5	16	-	-
	103	0.36	290	230	0.57
	130	0.35	376	290	0.55
	176	0.26	684	400	0.41
90	24	1.85	13	-	-
	103	0.42	244	230	0.66
	130	0.35	376	290	0.55
100 and 112	24	1.85	13	-	-
	103	0.42	244	230	0.66
	130	0.35	376	290	0.55
	176	0.31	575	400	0.49
132	24	2.93	8.58	-	-
	130	0.56	232	290	0.88
	176	0.49	360	400	0.77

### Mounting brakes type ...SM(N)

Size Motor	Voltage U = [Nm]	Current I = [A]	Output P = [W]	Voltage U ~ [V]	Current I ~ [A]	Resistance R [Ω]
CM 71	24	0.92	22	-	-	26
CM 80	24	1.54	37	-	-	15
	104	0.43	44	230	0.16	293
	180	0.23	42	400	0.37	771
	207	0.19	40	460	0.09	1072
CM 90	24	1.54	37	-	-	15
	104	0.43	44	230	0.16	771
	180	0.23	42	400	0.37	293
	207	0.19	40	460	0.09	1072
CM100	24	2.42	58	-	-	10
	104	0.56	58	230	0.88	186
	180	0.33	59	400	0.52	550
	207	0.30	62	460	0.48	691
CM112 (M60)	24	2.42	58	-	-	10
	104	0.56	58	230	0.88	186
	180	0.33	59	400	0.52	550
	207	0.30	62	460	0.48	691
CM132 (M100)	24	3.42	82	-	-	7
	104	0.83	86	230	1.3	126
	180	0.46	82	400	0.72	395
	207	0.43	89	460	0.68	481
CM160 (M150)	24	3.96	95	-	-	6
	104	0.94	98	230	1.48	111
	180	0.53	94	400	0.82	345
	207	0.48	99	460	0.75	433

### Mounting brakes type ...S

Size Motor	Torque M [Nm]	Voltage U = [Nm]	Current I = [A]	Resistance R <sub>min</sub> [Ω]	Voltage U ~ [V]	Current I ~ [A]
10/11	10 or 20	24	2.1	11.6	-	-
		98	0.55	177	110	0.61
		205	0.27	770	230	0.3
		215	0.225	954	240	0.25
		258	0.21	1197	270	0.23
		356	0.14	2571	400	0.16
		13/16	50 or 100	24	2.93	8.2
98	0.8	122.4		110	0.89	
205	0.39	536		230	0.44	
215	0.346	621		240	0.38	
258	0.31	838		270	0.34	
356	0.2	1685		400	0.24	
19/24	150 or 270	24	3.08	7.8	-	-
		98	0.85	116	110	0.94
		205	0.4	516	230	0.45
		215	0.4	538	240	0.44
		356	0.25	1438	400	0.28

ATTENTION: From 01.07.2021, motors with efficiency classes IE1 and IE2 may only be supplied to the EU area as replacement motors for identical ATB motors that are already in operation.

# IE3

## Three-phase asynchronous motors with integrated frequency inverter

Compact drive  
Temperature class T4  
2p = 2, 4

118

40 °C ambient temperature, winding heating within heat class F

Operation on	Mains		Inverter								Inverter		
			square decreasing		constant		constant		constant		constant		decreasing
Torque trend	-												
Frequency	50 Hz	5-50 Hz	20-50 Hz		10-50 Hz		5-50 Hz		2-50 Hz		50-100 Hz		
Control range	-	1:10	1:2.5		1:5		1:10		1:25				
Speed range	-	300-3000 rpm	1200-3000 rpm		600-3000 rpm		300-3000 rpm		120-3000 rpm		3000-6000 rpm		
Power/torque	P <sub>2</sub> [kW]	P <sub>U</sub> [kW]	M <sub>U</sub> [Nm]	P <sub>U</sub> [kW]	M <sub>U</sub> [Nm]	P <sub>U</sub> [kW]	M <sub>U</sub> [Nm]	P <sub>U</sub> [kW]	M <sub>U</sub> [Nm]	P <sub>U</sub> [kW]	M <sub>U</sub> [Nm]	P <sub>U</sub> [kW]	M <sub>U</sub> [Nm]
		50 Hz		50 Hz		50 Hz		50 Hz		50 Hz		100 Hz	
80M1-2 I	0.75	0.75	2.6	0.7	2.4	0.6	2	0.5	1.7	0.47	1.6	0.75	1.3
80M2-2 I	1.1	1.1	3.7	1	3.4	0.9	3	0.75	2.5	0.7	2.35	1.1	1.9
90S-2 I	1.5	1.5	5	1.4	4.7	1.2	4	1	3.3	0.94	3.3	1.2	2
90L-2 I	2.2	2.2	7.4	2	6.7	1.7	5.7	1.4	4.7	1.3	4.4	2	3.4
100L-2 I	3	3	10	2.7	8.9	2.2	7.2	1.8	5.9	1.7	5.5	3	5
112M-2 I	4	4	13	3.7	12	3.2	11	2.5	8.2	2.35	7.7	3.5	5.8
132S1-2 I	5.5	5.5	18	5	16	4.5	15	3.7	12	3.3	10.8	4.8	7.9

Operation on	Mains		Inverter								Inverter		
			square decreasing		constant		constant		constant		constant		decreasing
Torque trend	-												
Frequency	50 Hz	5-50 Hz	20-50 Hz		10-50 Hz		5-50 Hz		2-50 Hz		50-100 Hz		
Control range	-	1:10	1:2.5		1:5		1:10		1:25				
Speed range	-	150-1500 rpm	600-1500 rpm		300-1500 rpm		150-1500 rpm		60-1500 rpm		1500-3000 rpm		
Power/torque	P <sub>2</sub> [kW]	P <sub>U</sub> [kW]	M <sub>U</sub> [Nm]	P <sub>U</sub> [kW]	M <sub>U</sub> [Nm]	P <sub>U</sub> [kW]	M <sub>U</sub> [Nm]	P <sub>U</sub> [kW]	M <sub>U</sub> [Nm]	P <sub>U</sub> [kW]	M <sub>U</sub> [Nm]	P <sub>U</sub> [kW]	M <sub>U</sub> [Nm]
		50 Hz		50 Hz		50 Hz		50 Hz		50 Hz		100 Hz	
80M1-4 I	0.55	0.55	3.8	0.52	3.5	0.45	3	0.33	2.2	0.31	2.05	0.4	1.4
80M2-4 I	0.75	0.75	5.2	0.7	4.8	0.6	4	0.5	3.3	0.47	3.1	0.6	2
90LS-4 I	1.1	1.1	7.5	1	6.7	0.9	6	0.75	5	0.7	4.7	0.9	2.9
90L-4 I	1.5	1.5	10	1.4	9.5	1.2	8	1	6.7	0.94	6.3	1.2	4
100L1-4 I	2.2	2.2	15	2	13	1.7	11	1.4	9.3	1.3	8.7	1.9	6.4
100L2-4 I	3	3	20	2.8	19	2.2	15	1.8	12	1.7	11.3	2.6	8.5
112M-4 I	4	4	27	3.6	24	3	20	2.5	16	2.35	15	3.5	11.6
132S-4 I	5.5	5.5	37	5	33	4.4	29	3.7	24	3.3	21.6	4.7	15.3

# Noise class 4, water-cooled motors Mains operation 50 Hz

Temperature class T4,  
2p = 2, 4

119

Size	Output	Rated current at 400V	Speed	Efficiency	Power factor	Starting torque	Starting current	Weight <sup>2)</sup>	Cooling water quantity	Noise values	
CD...W	P <sub>2</sub> [kW]	I [A]	n [rpm]	η [%]	cos φ	M <sub>A</sub> / M <sub>N</sub>	I <sub>A</sub> / I <sub>N</sub>	m [kg]	[l/min] 30°C	L <sub>P</sub> [dB (A)]	L <sub>W</sub> [dB (A)]
<b>n<sub>s</sub> = 3000 rpm 2p = 2</b>											
<b>Efficiency according to manufacturer's standard</b>											
160M1-2	15	28.5	2915	87.5	0.87	2.5	6.5	125	6	51	64
160M2-2	18.5	33.5	2915	89	0.89	2.5	6.5	140	6	51	64
160L-2	22	39.5	2915	89.5	0.9	2.7	6.8	150	6	51	64
180M-2	30	54	2915	90	0.89	2.6	6.9	170	7	51	64
200L1-2	37	68	2950	92.5	0.85	3	7.2	270	9	52	66
200L2-2	45	81	2960	93	0.86	3.5	7.8	290	9	52	66
225M-2	55	100	2965	93	0.85	2.8	7.1	455	9	54	68
250M-2	75	139	2970	93	0.84	2.7	6.9	564	10	57	71
280S-2	90	154	2970	93.5	0.9	2	6.5	665	11	59	73
280M-2	110	191	2970	93.5	0.89	2.1	6.8	776	11	59	73
315S-2	132	225	2975	94.5	0.89	1.9	6.3	1010	12	60	75
315M-2	160	270	2975	95.5	0.89	1.8	6.7	1100	12	60	75
315L1-2	200	340	2975	95.5	0.89	2	6.9	1200	15	60	75
315L2-2	250	420 <sup>1)</sup>	2980	96	0.9	1.7	6.9	1300	17	60	75
315L3-2	315	515 <sup>1)</sup>	2980	96	0.92	1.5	6.8	1450	17	60	76
355L1-2	355	575 <sup>1)</sup>	2985	96.5	0.92	1.5	6.8	2100	18	60	76
355L2-2	400	650 <sup>1)</sup>	2985	96.8	0.92	1.5	6.8	2300	20	60	76
<b>n<sub>s</sub> = 1500 rpm 2p = 4</b>											
<b>Efficiency according to manufacturer's standard</b>											
160M-4	13.5	29	1450	86.5	0.78	2.6	6.1	130	6	51	64
160L-4	18.5	36	1450	89	0.84	2.5	6.2	150	6	51	64
180M-4	22	43.5	1460	90	0.81	3.1	6.7	170	7	51	64
180L-4	27	53	1455	90	0.81	3	6.5	190	7	51	64
200L-4	37	67	1460	91	0.87	2.7	6.8	295	9	51	65
225S-4	45	81	1465	92	0.87	2.9	6.5	441	9	52	66
225M-4	55	100	1470	92.5	0.86	3.2	6.6	480	9	52	66
250M-4	70	127	1475	92.5	0.86	2.9	7.1	590	10	56	70
280S-4	90	163	1480	93.5	0.85	2.7	6.7	745	11	58	72
280M-4	110	199	1480	94	0.85	2.9	6.9	850	11	58	72
315S-4	132	240	1485	95	0.84	2.2	6.6	1050	12	57	72
315M-4	160	290	1485	95.5	0.84	2.8	6.8	1115	12	57	72
315L1-4	200	350	1485	95.5	0.86	2.5	6.8	1200	15	57	72
315L2-4	250	435 <sup>1)</sup>	1490	96	0.86	2	6.9	1300	17	57	72
315L3-4	315	545 <sup>1)</sup>	1490	96	0.87	1.5	6.8	1600	17	58	74
355L1-4	355	590 <sup>1)</sup>	1490	96.5	0.9	1.5	6.8	2250	18	58	74
355L2-4	400	665 <sup>1)</sup>	1490	96.7	0.9	1.5	6.8	2450	20	58	74

**Note:**

<sup>1)</sup> Two parallel supply lines are required in each case

<sup>2)</sup> Type B3 with terminal compartment type EAR

# High voltage motors

## Mains operation 50 Hz

120

Temperature class T4,  
2p = 2, 4, 6, 8

Size	Output	Rated current at 6000 V	Speed	Efficiency	Power factor	Torque	Starting torque	Starting current	Breakdown torque	Mass moment of inertia	Weight <sup>(2)</sup>	Noise values with radial fan	
CD...H	P <sub>2</sub> [kW]	I [A]	n [rpm]	η [%]	cos φ	M [Nm]	M <sub>A</sub> / M <sub>N</sub>	I <sub>A</sub> / I <sub>N</sub>	M <sub>K</sub> / M <sub>N</sub>	J [kgm <sup>2</sup> ]	m [kg]	L <sub>P</sub> [dB(A)]	L <sub>W</sub> [dB(A)]
<b>n<sub>s</sub> = 3000 rpm 2p = 2</b>													
355M-2	160	18.1	2981	94.5	0.9	513	1.1	6.5	2.5	2.6	1825	82	98
355L1-2	200	22.5	2981	94.8	0.9	641	1.1	6.6	2.5	3.1	2008	82	98
355L2-2	250	28	2982	95	0.91	801	1.1	6.6	2.6	3.4	2100	82	98
400M-2	280	31	2982	95.3	0.91	897	1	6.4	2.6	7.7	2389	82	98
400L-2	315	35	2982	95.5	0.91	1009	1	6.5	2.6	10.1	2800	82	98
450M1-2	355	39.5	2985	95.8	0.9	1136	0.9	6.6	2.7	9.4	3268	85	101
450M2-2	400	44.5	2987	96	0.9	1279	0.9	6.6	2.7	10.6	3437	85	101
450L1-2	450	49.5	2987	96.2	0.91	1439	0.9	6.5	2.6	12.6	3699	85	101
450L2-2	500	55	2988	96.4	0.91	1598	0.9	6.6	2.7	14.6	3962	85	101
450L3-2	560	61	2988	96.5	0.91	1790	0.9	6.5	2.6	16.8	4262	85	101
<b>n<sub>s</sub> = 1500 rpm 2p = 4</b>													
355M1-4	160	19.3	1488	94.8	0.84	1027	1.2	6.6	2.4	4.2	1800	73	89
355M2-4	220	26.5	1488	95.2	0.84	1412	1.2	6.6	2.4	5	1950	73	89
355L-4	280	33.5	1488	95.4	0.84	1797	1.2	6.6	2.4	5.9	2213	73	89
400M-4	315	37	1490	95.6	0.86	2019	1.1	6.6	2.5	12.9	3460	79	95
400L1-4	355	41.5	1490	95.8	0.86	2275	1.1	6.5	2.4	14.5	3665	79	95
400L2-4	400	46.5	1490	96	0.86	2564	1.1	6.6	2.5	16.4	3900	79	95
450M1-4	450	53	1491	96	0.85	2882	1	6.5	2.5	18.5	3887	80	96
450M2-4	500	59	1491	96.1	0.85	3203	1	6.6	2.5	20.7	4112	80	96
450L1-4	560	66	1492	96.2	0.85	3584	1	6.7	2.6	23.3	4375	80	96
450L2-4	630	73	1492	96.3	0.86	4033	0.9	6.5	2.4	26.2	4675	80	96
450L3-4	710	82	1492	96.5	0.86	4545	1	6.5	2.5	29.5	5012	80	96
<b>n<sub>s</sub> = 1000 rpm 2p = 6</b>													
355M-6	160	21	990	94.2	0.78	1543	1.2	6	2.2	5	1950	75	91
355L-6	200	26	990	94.3	0.79	1929	1.2	5.9	2.1	5.9	2179	75	91
400M-6	250	31	991	95.2	0.81	2409	1.2	6.4	2.3	12.9	3460	78	94
400L1-6	280	35	991	95.4	0.81	2698	1.2	6.5	2.3	14.5	3665	78	94
400L2-6	315	39	991	95.6	0.81	3036	1.2	6.5	2.3	16.4	3900	78	94
450M1-6	355	42.5	991	95.6	0.84	3421	1	6.3	2.4	29.1	4112	78	94
450M2-6	400	47.5	991	95.7	0.85	3855	1	6.3	2.4	32.7	4375	78	94
450L1-6	450	53	991	95.7	0.86	4337	1	6.3	2.4	36.8	4675	78	94
450L2-6	500	58	992	95.8	0.86	4814	1	6.4	2.4	41.5	5012	78	94
<b>n<sub>s</sub> = 750 rpm 2p = 8</b>													
400M-8	160	21.5	742	94.2	0.76	2059	1.1	5.3	2	12.9	3460	74	90
400L1-8	200	27	742	94.5	0.76	2574	1.1	5.5	2	14.5	3665	74	90
400L2-8	240	32	742	94.6	0.76	3089	1.1	5.5	2	16.4	3900	74	90
450M1-8	280	37	743	94.6	0.77	3599	1.1	5.8	2.3	29.1	4112	74	90
450M2-8	315	41	743	94.7	0.78	4049	1	5.7	2.3	32.7	4375	74	90
450L1-8	355	47	743	94.8	0.77	4563	1	5.9	2.4	36.8	4675	74	90
450L2-8	400	52	744	94.9	0.78	5134	1	6	2.4	41.5	5012	74	90



# IE3 / IE2

## Surface-cooling low voltage motors

### Self-cooling with radial fan

### Forced cooling with axial fan

122

Type IM B3, IM B6, IM B7, IM B8, IM V5<sup>1)</sup>, IM V6

Self-cooling image

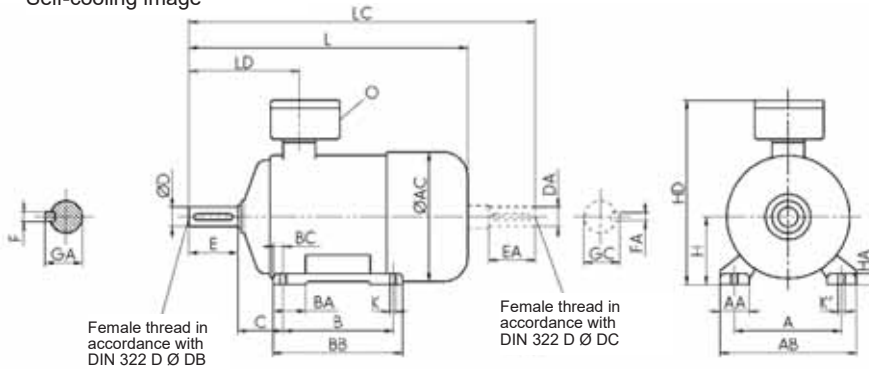

Lifting eyes from size 90.  
Dimension AC, measured above bolt head. Dimension HD, Ex e-related on terminal box.  
Terminal box 4 x 90° rotatable.

Note:  
Type IM V5 with protective roof; dimension LE see page 117.

Type CD...Y3/Y/Y2	A	AA	AB	AC	B	BA	BB	BC	C	H -0,5	HA	HD	K H17	K' H17	L Number of poles			
															2	4	6	8
63M	100	20	120	146	80	25	100	10	40	63	6	227	Ø 7	-	270	270	-	-
71M	112	27	139	140	90	32	110	10	45	71	10	248	Ø 8	-	301	301	301	301
80M	125	35	160	158	100	37	130	15	50	80	12	271	Ø 10	-	343	343	-	-
90S	140	38	180	178	100	44	130	15	56	90	12	295	Ø 10	-	398	398	398	398
90L	140	38	180	178	125	44	155	15	56	90	12	295	Ø 10	-	398	398	398	398
100L	160	42	200	198	140	46	175	17,5	63	100	15	305	Ø 12	-	419	419	419	419
112M	190	45	235	218	140	46	175	17,5	70	112	17	337	Ø 12	-	517	517	517	517
132S	216	60	266	265	140	60	187	23,5	89	132	20	393	Ø 12	-	-	529	529	529
132S1	216	60	266	265	140	60	187	23,5	89	132	20	393	Ø 12	-	529	-	-	-
132S2	216	60	266	265	140	60	187	23,5	89	132	20	393	Ø 12	-	579	-	-	-
132M	216	60	266	265	178	60	225	23,5	89	132	20	393	Ø 12	-	-	579	-	597
132M1	216	60	266	265	178	60	225	23,5	89	132	20	393	Ø 12	-	-	-	529	-
132M2	216	60	266	265	178	60	225	23,5	89	132	20	393	Ø 12	-	-	-	579	-
160M	254	65	310	318	210	100	300	23	108	160	25	459	15	20	713	676	676	676
160L Y2	254	65	310	318	254	100	300	23	108	160	25	459	15	20	713	676	676	-
160L Y3,Y	254	65	310	318	254	100	300	23	108	160	25	459	15	20	713	711	711	676
180M	279	75	350	353	241	100	340	30	121	180	25	545	15	20	726	726	-	-
180L Y2	279	75	350	353	279	100	340	30	121	180	25	545	15	20	-	726	726	-
180L Y3,Y	279	75	350	353	279	100	340	30	121	180	25	545	15	20	-	776	726	726
200L	318	80	390	393	305	90	365	30	133	200	30	581	20	26	789	789	789	789
Type CD...Y3/Y/Y2	A	AA	AB	AC	B	BA	BB	BC	C	H	HA	HD	K H17	K' H17	L Number of Poles			
225S	356	85	450	455	286	90	370	29,5	149	225-0,5	35	634	20	26	-	937	-	888
225M	356	85	450	455	311	90	370	29,5	149	225-0,5	35	634	20	26	907	937	888	888
250M	406	105	510	493	349	110	420	35,5	168	250-0,5	40	731	26	35	1000	1000	934	934
280S	457	110	570	548	368	120	500	40,5	190	280-1	45	802	26	35	1109	1109	1109	1109
280M	457	110	570	548	419	120	500	40,5	190	280-1	45	802	26	35	1109	1109	1109	1109
315S	508	150	630	635	406	210	615	53	216	315-1	40	897	39	30	1268	1298	1218	1218
315M	508	150	630	635	457	210	615	53	216	315-1	40	897	39	30	1268	1298	1218	1218
315L1	508	150	630	635	508	210	615	53	216	315-1	40	897	39	30	1268	1298	1218	1298
315L2	508	150	630	635	508	210	615	53	216	315-1	40	897	39	30	1468	1498	1418	1498
315L3	508	150	630	635	508	210	615	53	216	315-1	40	897	39	30	1468	1498	1418	1498
355M	610	180	720	725	560	220	720	45	254	355-1	50	1084	30	39	-	-	-	1697
Type CD...XY3/XY/XY3	A	AA	AB	AC	B	BA	BB	BC	C	H	HA	HD	K H17	K' H17	L Number of Poles			
250S	406	110	510	493	311	110	420	30	168	250-0,5	45	731	Ø 26,5	-	1000	1000	934	934
250M	406	110	510	548	349	110	420	30	168	250-0,5	45	762	Ø 26,5	-	1109	1109	1109	1109
280S	457	110	570	548	368	120	500	40,5	190	280-1	45	802	26	35	1109	1109	1109	1109
280M	457	110	570	635	419	-	570	40	190	280-1	48	862	Ø 26,5	-	1268	1298	1218	1218
315S	508	150	630	635	406	210	615	53	216	315-1	40	897	39	30	1268	1298	1218	1218
315M	508	150	630	635	457	210	615	53	216	315-1	40	897	39	30	1268	1298	1218	1298
315L1	508	150	630	635	508	210	615	53	216	315-1	40	897	39	30	1468	1498	1218	1298
315L2	508	150	630	635	508	210	615	53	216	315-1	40	897	39	30	1468	1498	1418	1498

\*\*\*\* British version



# IE1

## Surface-cooling low voltage motors

### Self-cooling with radial fan

### Forced cooling with axial fan

124

Type IM B3, IM B6, IM B7, IM B8, IM V5<sup>1)</sup>, IM V6

Self-cooling image

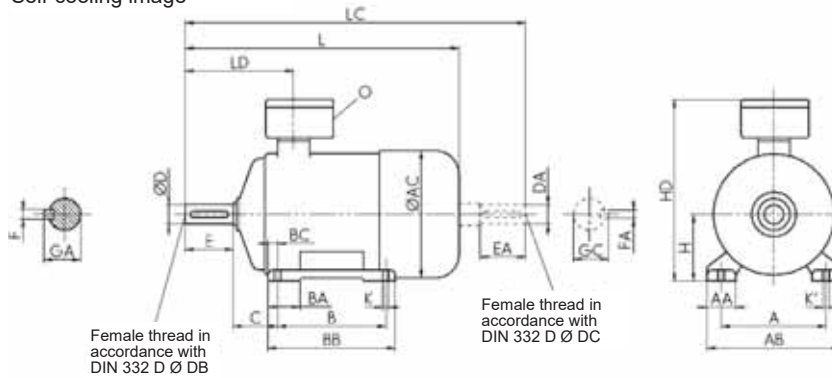

Size 63 in T4, not ventilated.

Lifting eyes from size 90.  
Dimension AC, measured above bolt head.  
Dimension HD in relation to Ex e box.  
Terminal box can be rotated 4 x 90°. Also applies to BD series...

Note:  
1) Type IM V5 with protective roof, see dimension LE page 117

Type CD...	A	AA	AB	AC	B	BA	BB	BC	C	H -0,5	HA	HD	K H17	K' H17	L Number of poles			
															2	4	6	8
63M	100	20	120	134	80	25	100	10	40	63	6	227	Ø 7	-	239	239	239	239
71M	112	30	139	145	90	25	110	10	45	71	10	235	Ø 7	-	278	278	278	278
80M	125	35	160	163	100	35	130	15	50	80	12	260	Ø 10	-	313	313	313	313
90S	140	40	180	183	100	40	130	15	56	90	12	275	Ø 10	-	364	364	364	364
90L	140	40	180	183	125	40	155	15	56	90	12	275	Ø 10	-	364	364	364	364
100L	160	45	200	201	140	45	175	17,5	63	100	15	305	Ø 12	-	415	415	415	415
112M	190	50	235	225	140	50	175	17,5	70	112	17	317	Ø 12	-	425	425	425	425
132S	216	60	266	265	140	60	187	23,5	89	132	20	393	Ø 12	-	529	529	529	529
132M	216	60	266	265	178	60	225	23,5	89	132	20	393	Ø 12	-	-	529	529	529
160M	254	65	310	318	210	100	300	23	108	160	25	459	15	20	713	676	676	676
160L	254	65	310	318	254	100	300	23	108	160	25	459	15	20	713	676	676	676
180M	279	75	350	353	241	100	340	30	121	180	25	545	15	20	726	726	-	-
180L	279	75	350	353	279	100	340	30	121	180	25	545	15	20	-	726	726	726
200L	318	80	390	393	305	90	365	30	133	200	30	581	20	26	789	789	789	789
Type CD...	A	AA	AB	AC	B	BA	BB	BC	C	H	HA	HD	K H17	K' H17	L Number of poles			
															2	4	6	8
225S	356	85	450	455	286	90	370	29,5	149	225-0,5	35	634	20	26	-	937	-	888
225M	356	85	450	455	311	90	370	29,5	149	225-0,5	35	634	20	26	907	937	888	888
250M	406	105	510	493	349	110	420	35,5	168	250-0,5	40	731	26	35	1000	1000	934	934
280S	457	110	570	548	368	120	500	40,5	190	280-1	45	802	26	35	1109	1109	1109	1109
280M	457	110	570	548	419	120	500	40,5	190	280-1	45	802	26	35	1109	1109	1109	1109
315S	508	150	630	635	406	210	615	53	216	315-1	40	897	39	30	1268	1298	1218	1218
315M	508	150	630	635	457	210	615	53	216	315-1	40	897	39	30	1268	1298	1218	1218
315L1	508	150	630	635	508	210	615	53	216	315-1	40	897	39	30	1268	1298	1218	1298
315L2	508	150	630	635	508	210	615	53	216	315-1	40	897	39	30	1468	1498	1418	1498
315L3	508	150	630	635	508	210	615	53	216	315-1	40	897	39	30	1468	1498	1418	1498
355M	610	180	720	725	560	220	720	45	254	355-1	50	1084	30	39	-	-	1597	1597
355L1	610	180	720	725	630	220	720	45	254	355-1	50	1084	30	39	1667	1697	1597	1597
355L2	610	180	720	725	630	220	720	45	254	355-1	50	1084	30	39	1667	1667	1597	1597
355L3	610	180	720	725	630	220	720	45	254	355-1	50	1084	30	39	1747	1777	-	-
400M	686	130	800	810	630	150	1264	152	280	400-1	34	1146	Ø 35	-	-	1907	1907	1907
400L	686	130	800	810	710	150	1264	152	280	400-1	34	1146	Ø 35	-	1837	1907	1907	1907
450M	760	150	900	910	710	180	1135	150	280	450-1	35	1264	Ø 35	-	-	1903	1903	1903
450L	760	150	900	910	840	180	1135	150	280	450-1	35	1264	Ø 35	-	-	1903	1903	1903

Forced cooling image

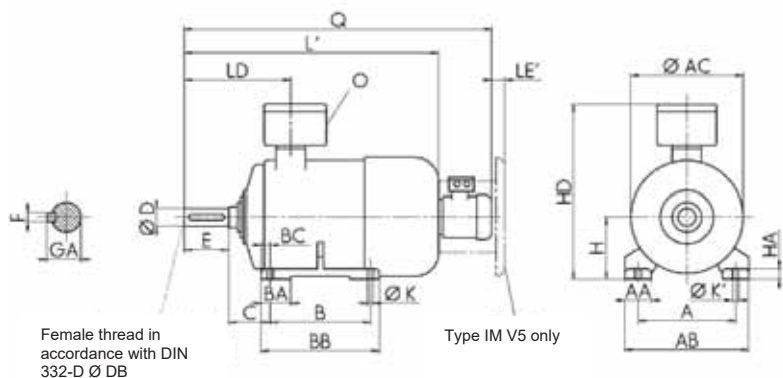

Note:

1) For type 250 to 400-4, 6, 8 dimension DA, EA, GC, FA, DC the specifications of number of poles 2 apply  
For type 450-6, 8 DA, EA, GC, FA, DC the specifications of number of poles 4 apply

type CD...	LC Number of poles			LD	O	Shaft end D, DA			E, EA	GA, GC			F, FA	DB, DC			Fan motor Type CD	Type CD...F				LE'		
	2	4	6, 8			2	4	6, 8		2	4	6, 8		2	4	6, 8		2	4	6, 8	L'		Q	2
63M	274	274	274	104	M25x1,5	11j6			23		12,5		4		M4	-	-	-	-	-	-			
71M	334	334	334	111	M25x1,5	14j6			30		16		5		M5	-	-	-	-	-	-			
80M	387	387	387	116	M25x1,5	19j6			40		21,5		6		M6	-	-	-	-	-	-			
90S	445	445	445	137	M25x1,5	24j6			50		27		8		M8	-	-	-	-	-	-			
90L	445	445	445	137	M25x1,5	24j6			50		27		8		M8	-	-	-	-	-	-			
100L	510	510	510	149	M32x1,5	28j6			60		31		8		M10	-	-	-	-	-	-			
112M	526	526	526	154	M32x1,5	28j6			60		31		8		M10	63M1-4	515	515	731	731	30			
132S	645	645	645	226	M32x1,5	38k6			80		41		10		M12	63M1-4	606	606	822	822	36			
132M	-	645	645	226	M32x1,5	38k6			80		41		10		M12	63M1-4	-	606	-	822	36			
160M	864	864	864	261	M40x1,5	42k6			110		45		12		M16	63M1-4	757	757	972	972	38			
160L	864	864	864	261	M40x1,5	42k6			110		45		12		M16	63M1-4	757	757	972	972	38			
180M	909	909	-	369	M40x1,5	48k6			110		51,5		14		M16	63M1-4	746	746	960	960	38			
180L	-	909	909	369	M40x1,5	48k6			110		51,5		14		M16	63M1-4	-	746	-	960	38			
200L	983	983	983	390	M50x1,5	55m6			110		59		16		M20	63M1-4	803	803	1018	1018	38			
Type CD...	LC Number of poles			LD	O	Shaft end D m6, DA m6 <sup>1)</sup>			E, EA <sup>1)</sup>	GA, GC <sup>1)</sup>			F, FA <sup>1)</sup>	DB, DC <sup>1)</sup>			Fan motor Type CD	Type CD...F				LE'		
	2	4	6, 8			2	4	6, 8		2	4	6, 8		2	4	6, 8		2	4	6, 8	L'		Q	2
225S	-	1175	1175	-	377	M50x1,5	-	60	60	-	140	-	64	64	-	18	-	M20	63M1-4	-	938	-	1153	38
225M	1145	1175	1175	347	377	M50x1,5	55	60	60	110	140	59	64	64	16	18	M20	M20	63M1-4	908	938	1153	1153	38
250M	1250	1250	1250	482	482	M63x1,5	60	65	65	140	140	64	69	69	18	18	M20	M20	63M1-4	1019	1019	1234	1234	38
280S	1375	1375	1375	483	483	M63x1,5	65	75	75	140	140	69	79,5	79,5	18	20	M20	M20	71M2-4Y3	-	-	-	-	by request
280M	1375	1375	1375	483	483	M63x1,5	65	75	75	140	140	69	79,5	79,5	18	20	M20	M20	71M2-4 Y3	-	-	-	-	by request
315S	1543	1573	1573	496	526	M63x1,5	65	80	80	140	170	69	85	85	18	22	M20	M20	71M2-4 Y3	-	-	-	-	by request
315M	1543	1573	1573	496	526	M63x1,5	65	80	80	140	170	69	85	85	18	22	M20	M20	71M2-4 Y3	-	-	-	-	by request
315L1	1543	1573	1573	496	526	M63x1,5	65	80	80	140	170	69	85	85	18	22	M20	M20	71M2-4 Y3	-	-	-	-	by request
315L2	1743	1773	1773	496	526	M63x1,5	65	80	80	140	170	69	85	85	18	22	M20	M20	71M2-4 Y3	-	-	-	-	by request
315L3	1743	1773	1773	496	526	M63x1,5	65	80	80	140	170	69	85	85	18	22	M20	M20	71M2-4 Y3	-	-	-	-	by request
355M	-	-	1980	-	702	M80x2	75	90	90	140	170	79,5	95	95	20	25	M20	M24	-	-	-	-	-	-
355L1	1925	1980	1980	672	702	M80x2	75	90	90	140	170	79,5	95	95	20	25	M20	M24	80M1-4 Y3	-	-	-	-	by request
355L2	1950	1980	1980	672	702	M80x2	75	90	90	140	170	79,5	95	95	20	25	M20	M24	80M1-4 Y3	-	-	-	-	by request
355L3	2030	2060	-	672	702	M80x2	75	90	90	140	170	79,5	95	95	20	25	M20	M24	80M1-4 Y3	-	-	-	-	by request
400M	-	2190	2190	-	788	M95x2	75	100	100	140	210	79,5	106	106	20	28	M20	M24	80M2-4 Y3	-	-	-	-	by request
400L	2120	2190	2190	718	788	M95x2	75	100	100	140	210	79,5	106	106	20	28	M20	M24	80M2-4 Y3	-	-	-	-	by request
450M	-	2280	2280	-	826	M95x2	75	100	110	140	210	79,5	106	116	20	28	M20	M24	90S-4 Y3	-	-	-	-	by request
450L	-	2280	2280	-	826	M95x2	75	100	110	140	210	79,5	106	116	20	28	M20	M24	90S-4 Y3	-	-	-	-	by request

# IE3 / IE2

## Surface-cooling low voltage motors

### Self-cooling with radial fan / Forced cooling with axial fan

126

Type IM B5, IM V1<sup>1)</sup>, IM V3

Self-cooling image

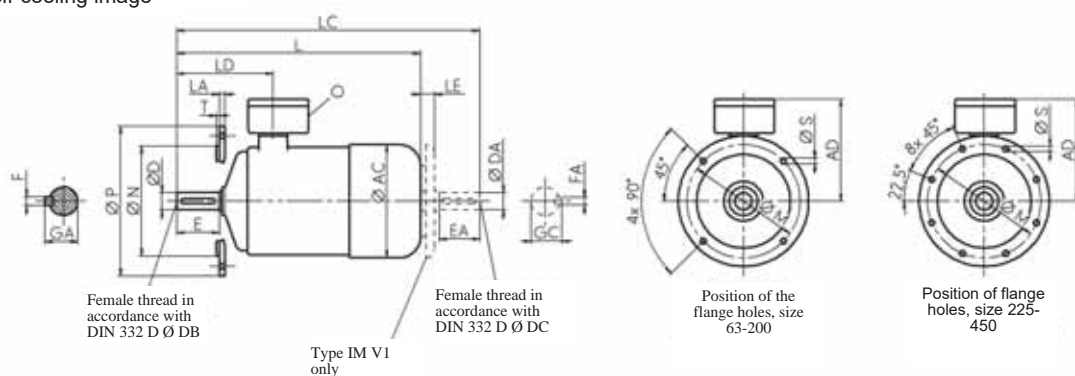

Type CD...Y3/Y/Y2	Mounting flange								L				LC				
	LA	M	N	P	SH17	T	AC	AD	Number of poles				Number of poles				
									2	4	6	8	2	4	6	8	
63M	9	115	95 j6	140	10	3	146	164	270	270	–	–	by request	–	–	–	–
71M	9	115	95 j6	140	10	3	140	177	301	301	301	301	380	380	380	380	380
80M	12	165	130 j6	200	12	3,5	158	185	343	343	–	–	417	417	–	–	–
90S+L	12	165	130 j6	200	12	3,5	178	198	398	398	398	398	479	479	479	479	479
100L	16	215	180 j6	250	14,5	4	198	205	419	419	419	419	515	515	515	515	515
112M	16	215	180 j6	250	14,5	4	218	225	517	517	517	517	608	608	608	608	608
132S	16	265	230 j6	300	14,5	4	265	261	–	529	529	529	–	645	645	645	645
132S1	16	265	230 j6	300	14,5	4	265	261	529	–	–	–	645	–	–	–	–
132S2	16	265	230 j6	300	14,5	4	265	261	579	–	–	–	695	–	–	–	–
132M	16	265	230 j6	300	14,5	4	265	261	–	579	–	529	–	695	–	645	645
132M1	16	265	230 j6	300	14,5	4	265	261	–	–	529	–	–	–	645	–	–
132M2	16	265	230 j6	300	14,5	4	265	261	–	–	579	–	–	–	695	–	–
160M	20	300	250 j6	350	18,5	5	318	299	713	676	676	676	864	864	864	864	864
160L Y2	20	300	250 j6	350	18,5	5	318	299	713	676	676	–	864	864	864	–	–
160L Y3/Y	20	300	250 j6	350	18,5	5	318	299	713	711	711	676	864	899	899	864	864
180M	20	300	250 j6	350	18,5	5	353	365	726	726	–	–	909	909	–	–	–
180L Y2	20	300	250 j6	350	18,5	5	353	365	–	726	726	–	–	909	909	–	–
180L Y3/Y	20	300	250 j6	350	18,5	5	353	365	–	776	726	726	–	959	909	909	909
200L	20	350	300 h6	400	18,5	5	393	381	789	789	789	789	983	909	909	909	909
Type CD...Y3/Y/Y2	Mounting flange								L				LC				
	LA	M	N	P	SH17	T	AC	AD	Number of poles				Number of poles				
									2	4	6	8	2	4	6	8	
225S	22	400	350	450	18,5	5	455	409	–	937	–	888	–	1175	1175	1175	1175
225M	22	400	350	450	18,5	5	455	409	907	937	888	888	1145	1175	1175	1175	1175
250M	18	500	450	550	18,5	5	493	481	1000	1000	934	934	1250	1250	1184	1184	1184
280S	18	500	450	550	18,5	5	548	522	1109	1109	1109	1109	1375	1375	1375	1375	1375
280M	18	500	450	550	18,5	5	548	522	1109	1109	1109	1109	1375	1375	1375	1375	1375
315S	22	600	550	660	24	6	635	582	1268	1298	1218	1218	1543	1573	1573	1573	1573
315M	22	600	550	660	24	6	635	582	1268	1298	1218	1218	1543	1573	1573	1573	1573
315L	22	600	550	660	24	6	635	582	1268	1298	1218	1298	1543	1573	1573	1573	1573
315L2	22	600	550	660	24	6	635	582	1468	1498	1418	1498	1743	1773	1773	1773	1773
315L3	22	600	550	660	24	6	635	582	1468	1498	1418	1498	1743	1773	1773	1773	1773
355M	25	740	680	800	24	6	725	729	–	–	–	1697	–	–	–	–	1980
Type CD...XY2/XY3/XY	Mounting flange								L				LC				
	LA	M	N	P	SH17	T	AC	AD	Number of poles				Number of poles				
									2	4	6	8	2	4	6	8	
250S	18	500	450	550	18,5	5	493	481	1000	1000	934	934	1250	1250	1184	1184	1184
250M	18	500	450	550	18,5	5	548	476	1109	1109	1109	1109	1375	1375	1375	1375	1375
280S	18	500	450	550	18,5	5	548	522	1109	1109	1109	1109	1375	1375	1375	1375	1375
280M	18	500	450	550	18,5	5	635	582	1268	1298	1218	1218	1543	1573	1573	1573	1573
315S	22	600	550	660	24	6	635	582	1268	1298	1218	1218	1543	1573	1573	1573	1573
315M	22	600	550	660	24	6	635	582	1268	1298	1218	1298	1543	1573	1573	1573	1573
315L1	22	600	550	660	24	6	635	582	1468	1498	1218	1298	1743	1773	1773	1773	1773
315L2	22	600	550	660	24	6	635	582	1468	1498	1418	1498	1743	1773	1773	1773	1773

\*\*\*\* British version

Forcing cooled image

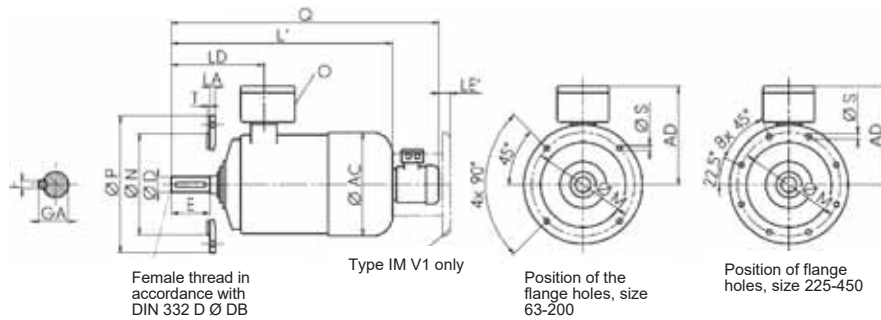

Mounting flange in accordance with EN 50347 form FF. Lifting eyes from size 90. Dimension AC, measured above bolt head. Dimension AD in relation to Ex e terminal compartment.  
Terminal compartment 4 x 90° rotatable.

Note:

- 1) Protective roof required for type IM V1, see, dimension LE; dimension LC includes LE.
- 2) For type 250 to 315-4,6,8 dimension DA, EA, GC, FA DC the specifications of number of poles 2 apply
- 3) With pole-changing motors (4/2, 6/4 and 8/4), the 4-pole shaft end is always installed  
Exception: Size 355, 400 and 450 motors with pole reversal 4/2. The 2-pole shaft end is used here.  
The length dimension L corresponds to the 4-pole motors for all sizes.

Type	LD	LE				O	Shaft end				Fan-motor	Type CD...F				LE'						
		Number of poles					D, DA	E, EA	GA, GC	F, FA		DB, DC	Q									
CD...Y3/Y/Y2		2	4	6	8						Type CD	2	4	6	8	2	4	6	8			
63M	104	25	25	—	—	M25x1,5	11 j6	23	12,5	4	M4	—	—	—	—	—	—	—	—	—		
71M	108,5	30	30	30	30	M25x1,5	14 j6	30	16	5	M5	—	—	—	—	—	—	—	—	—		
80M	127	25	25	25	25	M25x1,5	19 j6	40	21,5	6	M6	—	—	—	—	—	—	—	—	—		
90S+L	139	25	25	25	25	M25x1,5	24 j6	50	27	8	M8	—	—	—	—	—	—	—	—	—		
100L	154	30	30	30	30	M32x1,5	28 j6	60	31	8	M10	—	—	—	—	—	—	—	—	—		
112M	189	30	30	30	30	M32x1,5	28 j6	60	31	8	M10	63M1-4	588	588	588	588	803	803	803	803	30	
132S	226	30	30	30	30	M32x1,5	38 k6	80	41	10	M12	63M1-4	—	606	606	606	—	822	822	822	36	
32S1	226	30	30	30	30	M32x1,5	38 k6	80	41	10	M12	63M1-4	606	—	—	—	822	—	—	—	36	
132S2	226	30	30	30	30	M32x1,5	38 k6	80	41	10	M12	63M1-4	656	—	—	—	872	—	—	—	36	
132M	226	30	30	30	30	M32x1,5	38 k6	80	41	10	M12	63M1-4	—	656	—	606	—	872	—	822	36	
132M1	226	30	30	30	30	M32x1,5	38 k6	80	41	10	M12	63M1-4	—	—	606	—	—	—	822	—	36	
132M2	226	30	30	30	30	M32x1,5	38 k6	80	41	10	M12	63M1-4	—	—	656	—	—	—	872	—	36	
160M	261	66	66	66	66	M40x1,5	42 k6	110	45	12	M16	63M1-4	757	757	757	757	972	972	972	972	38	
160L Y2	261	66	66	66	—	M40x1,5	42 k6	110	45	12	M16	63M1-4	757	757	757	—	972	972	972	—	38	
160L Y3/Y	261	66	66	66	66	M40x1,5	42 k6	110	45	12	M16	63M1-4	757	792	792	757	972	1007	1007	972	38	
180M	369	66	66	—	—	M40x1,5	48 k6	110	51,5	14	M16	63M1-4	746	746	—	—	960	960	—	—	38	
180L Y2	369	—	66	66	—	M40x1,5	48 k6	110	51,5	14	M16	63M1-4	—	746	746	—	—	960	960	—	38	
180L Y3/Y	369	—	66	66	66	M40x1,5	48 k6	110	51,5	14	M16	63M1-4	—	796	746	746	—	1010	960	960	38	
200L	390	77	77	77	77	M50x1,5	55 m6	110	59	16	M20	63M1-4	803	803	803	803	1018	1018	1018	1018	38	
Type	LD	LE				O	Shaft end				Fan-motor	Type CD...F				LE'						
		Number of poles					D m6, DA m6 2)	E, EA 2)	GA, GC 2)	F, FA 2)		DB, DC 2)	Q									
CD...Y3/Y/Y2		2	4, 6, 8	2	4	6, 8		2	4, 6, 8	2	4, 6, 8	2	4, 6, 8	2	4, 6, 8	2	4, 6, 8	2	4, 6, 8			
225S	—	377	—	87	87	M50x1,5	—	60	—	140	—	64	—	18	—	M20	63M1-4	—	938	—	1153	38
225M	347	377	87	87	87	M50x1,5	55	60	110	140	59	64	16	18	M20	M20	63M1-4	908	938	—	1153	38
250M	482	482	94	94	94	M63x1,5	60	65	140	140	64	69	18	18	M20	M20	63M1-4	1019	1019	—	1234	38
280S	483	483	110	110	110	M63x1,5	65	75	140	140	69	79,5	18	20	M20	M20	71M2-4	1140	1140	—	1387	41
280M	483	483	110	110	110	M63x1,5	65	75	140	140	69	79,5	18	20	M20	M20	71M2-4	1140	1140	—	1387	41
315S	496	526	115	115	115	M63x1,5	65	80	140	170	69	85	18	22	M20	M20	71M2-4	1283	1313	—	1529	42
315M	496	526	115	115	115	M63x1,5	65	80	140	170	69	85	18	22	M20	M20	71M2-4	1283	1313	—	1529	42
315L1	496	526	115	115	115	M63x1,5	65	80	140	170	69	85	18	22	M20	M20	71M2-4	1283	1313	—	1529	42
315L2	496	526	115	115	115	M63x1,5	65	80	140	170	69	85	18	22	M20	M20	71M2-4	1483	1513	—	1729	42
315L3	496	526	115	115	115	M63x1,5	65	80	140	170	69	85	18	22	M20	M20	71M2-4	1483	1513	—	1729	42
355M	—	702	—	130	130	M80x2	—	90	—	170	—	95	—	25	—	M24	—	—	—	—	—	—
Type	LD	LE				O	Shaft end				Fan-motor	Type CD...F				LE'						
		Number of Poles					D m6, DA m6 2)	E, EA 2)	GA, GC 2)	F, FA 2)		DB, DC 2)	Q									
CD...XY2/XY3/XY		2	4, 6, 8	2	4	6, 8		2	4, 6, 8	2	4, 6, 8	2	4, 6, 8	2	4, 6, 8	2	4, 6, 8	2	4, 6, 8			
250S	482	482	94	94	94	M63x1,5	60	65*	140	140	64	69*	18	18*	M20	M20	—	—	—	—	—	—
250M	483	483	110	110	110	M63x1,5	60	65*	140	140	64	69*	18	18*	M20	M20	—	—	—	—	—	—
280S	483	483	110	110	110	M63x1,5	65	75**	140	140*	69	79,5**	18	20**	M20	M20	—	—	—	—	—	—
280M	496	526	115	115	115	M63x1,5	65	75**	140	140*	69	79,5**	18	20**	M20	M20	—	—	—	—	—	—
315S	496	526	115	115	115	M63x1,5	65	80***	140	170	69	85***	18	22	M20	M20	—	—	—	—	—	—
315M	496	526	115	115	115	M63x1,5	65	80***	140	170	69	85***	18	22	M20	M20	—	—	—	—	—	—
315L1	496	526	115	115	115	M63x1,5	65	80***	140	170	69	85***	18	22	M20	M20	—	—	—	—	—	—
315L2	496	526	115	115	115	M63x1,5	65	80***	140	170	69	85***	18	22	M20	M20	—	—	—	—	—	—

\* Diameter 70 for British version by request - please note: Dimension GA becomes 74.5 and dimension F becomes 20

\*\* Diameter 80 for British version by request - please note: Dimensions L, LC, LD and E become 30mm longer, dimension GA becomes 85 and dimension F becomes 22

\*\*\* Diameter 85 for British version by request - please note: Dimension GA becomes 90 and dimension F corresponds to the catalog

\*\*\*\* British version

# IE1

## Surface- cooling low voltage motors

### Self-cooling with radial fan

### Forced cooling with axial fan

128

Type IM B5, IM V1<sup>1)</sup>, IM V3

Self-cooling image

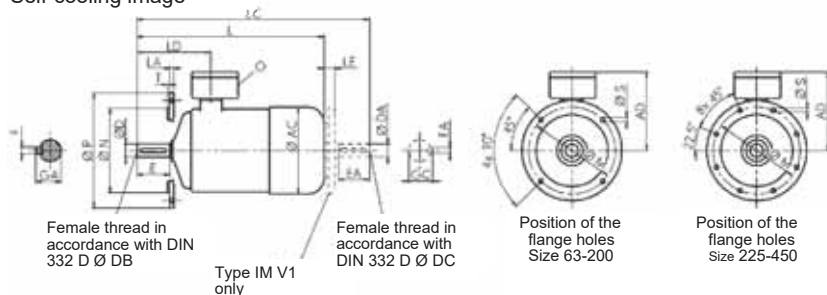

Size 63 in T4, not ventilated.  
 Mounting flange in accordance with EN 50347 form FF.  
 Lifting eyes from size 90.  
 Dimension AC measured above screw heads.  
 Dimension AD in relation to Ex e terminal compartment.  
 Terminal compartment, rotatable 4 x 90°.  
 Also applies to BD series...  
 Size 400-450 only available in type V1.

Note:

- 1) Protective roof required for type IM V1, see dimension LE page 117, dimension LC includes LE.

Type CD...	Mounting flange			P	SH17	T	AC	AD	L				LC			
	LA	M	N						Number of poles				Number of poles			
									2	4	6	8	2	4	6	8
63M	9	115	95j6	140	10	3	134	164	239	239	239	239	274	274	274	274
71M	9	130	110j6	160	10	3,5	145	164	278	278	278	278	334	334	334	334
80M	12	165	130j6	200	12	3,5	163	180	313	313	313	313	387	387	387	387
90S	12	165	130j6	200	12	3,5	183	185	364	364	364	364	445	445	445	445
90L	12	165	130j6	200	12	3,5	183	185	364	364	364	364	445	445	445	445
100L	16	215	180j6	250	14,5	4	201	205	415	415	415	415	510	510	510	510
112M	16	215	180j6	250	14,5	4	225	205	425	425	425	425	526	526	526	526
132S+M	16	265	230j6	300	14,5	4	265	261	529	529	529	529	645	645	645	645
160M+L	20	300	250j6	350	18,5	5	318	299	713	676	676	676	864	864	864	864
180M	20	300	250j6	350	18,5	5	353	365	726	726	-	-	909	909	-	-
180L	20	300	250j6	350	18,5	5	353	365	-	726	726	726	-	909	909	909
200L	20	350	300h6	400	18,5	5	393	381	789	789	789	789	983	983	983	983
Type CD...	Mounting flange			P	SH17	T	AC	AD	L				LC			
	LA	M	N						Number of poles				Number of poles			
									2	4	6	8	2	4	6	8
225S	22	400	350	450	18,5	5	455	409	-	937	-	888	-	1175	-	1175
225M	22	400	350	450	18,5	5	455	409	907	937	888	888	1145	1175	1175	1175
250M	18	500	450	550	18,5	5	493	471	1000	1000	934	934	1250	1250	1250	1250
280S	18	500	450	550	18,5	5	548	511	1109	1109	1109	1109	1375	1375	1375	1375
280M	18	500	450	550	18,5	5	548	511	1109	1109	1109	1109	1375	1375	1375	1375
315S	22	600	550	660	24	6	635	581	1268	1298	1218	1218	1543	1573	1573	1573
315M	22	600	550	660	24	6	635	581	1268	1298	1218	1218	1543	1573	1573	1573
315L1	22	600	550	660	24	6	635	581	1268	1298	1218	1298	1543	1573	1573	1573
315L2	22	600	550	660	24	6	635	581	1468	1498	1418	1498	1743	1773	1773	1773
315L3	22	600	550	660	24	6	635	581	1468	1498	1418	1498	1743	1773	1773	1773
355M	25	740	680	800	24	6	725	729	-	-	1597	1597	-	-	1980	1980
355L1	25	740	680	800	24	6	725	729	1667	1697	1597	1597	1925	1980	1980	1980
355L2	25	740	680	800	24	6	725	729	1667	1697	1597	1597	1950	1980	1980	1980
355L3	25	740	680	800	24	6	725	729	1747	1777	-	-	2030	2060	-	-
400M	28	940	880	1000	28	6	810	746	-	1907	1907	1907	-	2190	2190	2190
400L	28	940	880	1000	28	6	810	746	1837	1907	1907	1907	2120	2190	2190	2190
450M	28	940	880	1000	28	6	910	814	-	1903	1903	1903	-	2280	2280	2280
450L	28	940	880	1000	28	6	910	814	-	1903	1903	1903	-	2280	2280	2280

Forced cooling image

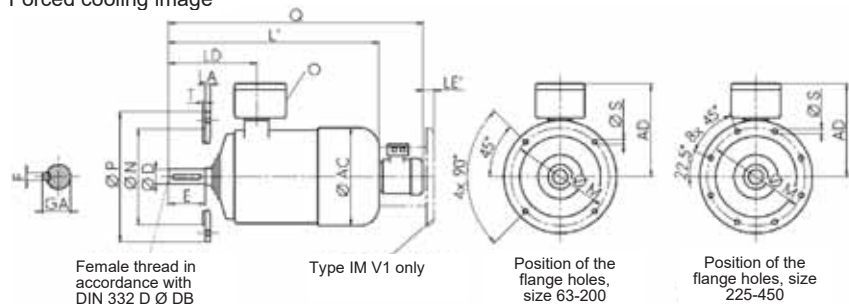

- 1) For type 250 to 400-4, 6, 8 dimension DA, EA, GC, FA, DC the specifications of number of poles 2 apply. For type 450-6, 8 Dimension DA, EA, GC, FA, DC the specifications for number of poles 4 apply.
- 2) With pole-changing motors (4/2, 6/4 and 8/4), the 4-pole shaft end is always installed. Exception: Size 355, 400 and 450 motors with pole reversal 4/2. The 2-pole shaft end is used here. The length dimension L corresponds to the 4-pole motors for all sizes.

Type CD...	LD			LE			O	Shaft end			E, EA	GA, GC			F, FA	DB, DC	Fan motor	Type CD...F			LE'		
	2	4	6, 8	2	4	6, 8		D, DA	2	4		6, 8	2	4				6, 8	Type CD	L'		2	4
63M	104	-	-	-	-	-	M25x1,5	11j6			23	12,5		4	M4	-	-	-	-	-	-	-	-
71M	111		25	25	25		M25x1,5	14j6			30	16		5	M5	-	-	-	-	-	-	-	-
80M	116		25	25	25		M25x1,5	19j6			40	21,5		6	M6	-	-	-	-	-	-	-	-
90S	137		25	25	25		M25x1,5	24j6			50	27		8	M8	-	-	-	-	-	-	-	-
90L	137		25	25	25		M25x1,5	24j6			50	27		8	M8	-	-	-	-	-	-	-	-
100L	149		30	30	30		M32x1,5	28j6			60	31		8	M10	-	-	-	-	-	-	-	-
112M	154		30	30	30		M32x1,5	28j6			60	31		8	M10	63M1-4	515	515	731	731	30		
132S+M	226		30	30	30		M32x1,5	38k6			80	41		10	M12	63M1-4	606	606	822	822	36		
160M+L	261		66	66	66		M40x1,5	42k6			110	45		12	M16	63M1-4	757	757	972	972	38		
180M	369		66	66	-		M40x1,5	48k6			110	51,5		14	M16	63M1-4	746	746	960	960	38		
180L	369		-	66	66		M40x1,5	48k6			110	51,5		14	M16	63M1-4	-	746	-	960	38		
200L	390		77	77	77		M50x1,5	55m6			110	59		16	M20	63M1-4	803	803	1018	1018	38		

Type CD...	LD			LE			O	Shaft end			E, EA <sup>1)</sup>	GA, GC <sup>1)</sup>			F, FA <sup>1)</sup>	DB, DC <sup>1)</sup>	Fan motor	Type CD...F			LE'					
	2	4	6, 8	2	4	6, 8		D m6, DA m6 <sup>1)</sup>	2	4		6, 8	2	4				6, 8	2	4		6, 8	Type CD	L'	2	4
225S	-	377	-	87	87		M50x1,5	-	60	60	-	140	-	64	64	-	18	-	M20	63M1-4	-	938	-	1153	38	
225M	347	377	87	87	87		M50x1,5	55	60	60	110	140	59	64	64	16	18	M20	M20	63M1-4	908	938	1153	1153	38	
250M	482	482	94	94	94		M63x1,5	60	65	65	140	140	64	69	69	18	18	M20	M20	63M1-4	1019	1019	1234	1234	38	
280S	483	483	110	110	110		M63x1,5	65	75	75	140	140	69	79,5	79,5	18	20	M20	M20	71M2-4	1140	1140	1387	1387	41	
280M	483	483	110	110	110		M63x1,5	65	75	75	140	140	69	79,5	79,5	18	20	M20	M20	71M2-4	1140	1140	1387	1387	41	
315S	496	526	115	115	115		M63x1,5	65	80	80	140	170	69	85	85	18	22	M20	M20	71M2-4	1283	1313	1529	1559	42	
315M	496	526	115	115	115		M63x1,5	65	80	80	140	170	69	85	85	18	22	M20	M20	71M2-4	1283	1313	1529	1559	42	
315L1	496	526	115	115	115		M63x1,5	65	80	80	140	170	69	85	85	18	22	M20	M20	71M2-4	1283	1313	1529	1559	42	
315L2	496	526	115	115	115		M63x1,5	65	80	80	140	170	69	85	85	18	22	M20	M20	71M2-4	1483	1513	1729	1759	42	
315L3	496	526	115	115	115		M63x1,5	65	80	80	140	170	69	85	85	18	22	M20	M20	71M2-4	1483	1513	1729	1759	42	
355M	-	702	130	130	130		M80x2	-	90	90	-	170	-	95	95	-	25	-	M24	-	-	-	-	-	-	
355L1	672	702	130	130	130		M80x2	75	90	90	140	170	79,5	95	95	20	25	M20	M24	80M1-4	1812	1842	2083	2113	40	
355L2	672	702	130	130	130		M80x2	75	90	90	140	170	79,5	95	95	20	25	M20	M24	80M1-4	1812	1842	2083	2113	40	
355L3	672	702	130	130	130		M80x2	75	90	90	140	170	79,5	95	95	20	25	M20	M24	80M1-4	1892	1922	2163	2193	40	
400M	-	788	130	130	130		M95x2	-	100	100	-	210	-	106	106	-	28	-	M24	80M2-4	1837	1907	2108	2178	40	
400L	718	788	130	130	130		M95x2	75	100	100	140	210	79,5	106	106	20	28	M20	M24	80M2-4	1837	1907	2108	2178	40	
450M	704	826	130	130	130		M95x2	75	100	110	140	210	79,5	106	116	20	28	M20	M24	90S-4	1880	1950	2192	2262	40	
450L	704	826	130	130	130		M95x2	75	100	110	140	210	79,5	106	116	20	28	M20	M24	90S-4	1880	1950	2192	2262	40	

# IE3 / IE2

## Surface- cooling low voltage motors

### Self-cooling with radial fan

130

Type IM B14, IM B34, IM V17<sup>1)</sup>, IM V18<sup>1)</sup>, IM V19, IM V37

Self-cooling image

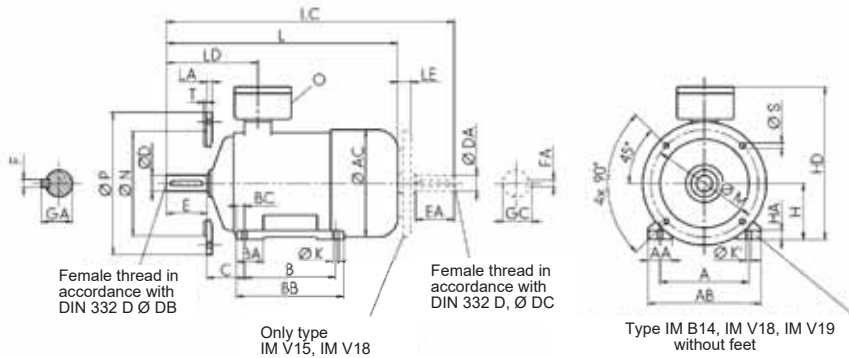

Mounting flange in accordance with EN 50347 Form FT. Lifting eyes from size 90. Dimension AC, measured above bolt head. Dimension HD in relation to Ex e terminal compartment. Terminal compartment, rotatable 4 x 90°.

Note:

- 1) With pole-changing motors (4/2, 6/4 and 8/4), the 4-pole shaft end is always installed. Exception: Size 355, 400 and 450 motors with pole reversal 4/2. The 2-pole shaft end is used here. The length dimension L corresponds to the 4-pole motors.

type	A	AA	AB	AC	B	BA	BB	BC	C	H-0,5	HA	HD	K H17	K' H17
CD...Y3/Y/Y2														
63M	100	20	120	146	80	25	100	10	40	63	6	227	Ø 7	-
71M	112	27	139	140	90	32	110	10	45	71	10	248	Ø 8	-
80M	125	35	160	158	100	37	130	15	50	80	12	265	Ø 10	-
90S	140	38	180	178	100	44	130	15	56	90	12	288	Ø 10	-
90L	140	38	180	178	125	44	155	15	56	90	12	288	Ø 10	-
100L	160	42	200	198	140	46	175	17,5	63	100	15	305	Ø 12	-
112M	190	45	235	218	140	46	175	17,5	70	112	17	337	Ø 12	-
132S	216	60	266	265	140	60	187	23,5	89	132	20	393	Ø 12	-
132S1	216	60	266	265	140	60	187	23,5	89	132	20	393	Ø 12	-
132S2	216	60	266	265	140	60	187	23,5	89	132	20	393	Ø 12	-
132M	216	60	266	265	178	60	225	23,5	89	132	20	393	Ø 12	-
132M1	216	60	266	265	178	60	225	23,5	89	132	20	393	Ø 12	-
132M2	216	60	266	265	178	60	225	23,5	89	132	20	393	Ø 12	-

type	L				LC				LE	LD	O
	Number of poles				Number of poles						
CD...Y3/Y/Y2	2	4	6	8	2	4	6	8			
63M	270	270	-	-	by request				25	104	M25x1,5
71M	301	301	301	301	380	380	380	380	30	108,5	M25x1,5
80M	343	343	-	-	417	417	-	-	25	127	M25x1,5
90S+L	398	398	398	398	479	479	479	479	25	139	M25x1,5
100L	419	419	419	419	515	515	515	515	30	154	M32x1,5
112M	517	517	517	517	608	608	608	608	30	189	M32x1,5
132S	-	529	529	529	-	645	645	645	30	226	M32x1,5
132S1	529	-	-	-	645	-	-	-	30	226	M32x1,5
132S2	579	-	-	-	695	-	-	-	30	226	M32x1,5
132M	-	579	-	529	-	695	-	645	30	226	M32x1,5
132M1	-	-	529	-	-	-	645	-	30	226	M32x1,5
132M2	-	-	579	-	-	-	695	-	30	226	M32x1,5

type	Shaft end					Mounting flange					
	D, DA	E, EA	GA, GC	F, FA	DB, DC	LA	M	N j6	P	S	T
CD...Y3/Y/Y2											
63M	11 j6	23	12,5	4	M4	8	75	60	90	M5	2,5
71M	14 j6	30	16	5	M5	8	85	70	105	M6	2,5
80M	19 j6	40	21,5	6	M6	10	100	80	120	M6	3
90S+L	24 j6	50	27	8	M8	10	115	95	140	M8	3
100L	28 j6	60	31	8	M10	12	130	110	160	M8	3,5
112M	28 j6	60	31	8	M10	12	130	110	160	M8	3,5
132S+M	38 k6	80	41	10	M12	12	165	130	200	M10	3,5

ATTENTION: From 01.07.2021, motors with efficiency classes IE1 and IE2 may only be supplied to the EU area as replacement motors for identical ATB motors that are already in operation.

IE1

# Surface-cooled low voltage motors Self-cooling with radial fan

Type IM B14, IM B34, IM V17<sup>1)</sup>, IM V18<sup>1)</sup>, IM V19, V37

131

Self-cooling image

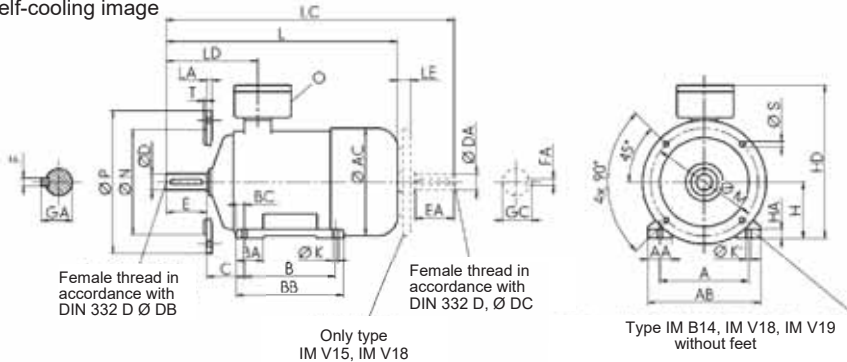

Female thread in accordance with DIN 332 D Ø DB

Female thread in accordance with DIN 332 D, Ø DC

Only type IM V15, IM V18

Type IM B14, IM V18, IM V19 without feet

Size 63 in T4, not ventilated. Mounting flange in accordance with EN 50347 Form FT. Lifting eyes from size 90. Dimension AC measured above screw heads. Dimension HD in relation to Ex e terminal compartment, rotatable 4 x 90°. Also applies to BD series...

Note:  
1) Protective roof required for types IM V17 and IM V18  
2) With pole-changing motors (4/2, 6/4 and 8/4), the 4-pole shaft end is always installed. Exception: Size 355, 400 and 450 motors with pole reversal 4/2.  
The 2-pole shaft end is used here.  
The length dimension L for all sizes corresponds to the 4-pole

Only Type IM V15, IM V18

Type CD...	A	AA	AB	AC	B	BA	BB	BC	C	H-0,5	HA	HD	K H17	K' H17
63M	100	20	120	134	80	25	100	10	40	63	6	227	Ø 7	-
71M	112	30	139	145	90	25	110	10	45	71	10	235	Ø 7	-
80M	125	35	160	163	100	35	130	15	50	80	12	260	Ø 10	-
90S	140	40	180	183	100	40	130	15	56	90	12	275	Ø 10	-
90L	140	40	180	183	125	40	155	15	56	90	12	275	Ø 10	-
100L	160	45	200	201	140	45	175	17,5	63	100	15	305	Ø 12	-
112M	190	50	235	225	140	50	175	17,5	70	112	17	317	Ø 12	-
132S	216	60	266	265	140	60	187	23,5	89	132	20	393	Ø 12	-
132M	216	60	266	265	178	60	225	23,5	89	132	20	393	Ø 12	-
Type CD...	L	LC	LE	LD	O	Shaft end					DB, DC			
63M	239	274	-	104	M25x1,5	11j6	23	12,5	4	M4				
71M	278	334	25	111	M25x1,5	14j6	30	16	5	M5				
80M	313	387	25	116	M25x1,5	19j6	40	21,5	6	M6				
90S+L	364	445	25	137	M25x1,5	24j6	50	27	8	M8				
100L	415	510	30	149	M32x1,5	28j6	60	31	8	M10				
112M	425	526	30	154	M32x1,5	28j6	60	31	8	M10				
132S+M	529	645	30	226	M32x1,5	38k6	80	41	10	M12				
Type CD...	Mounting flange													
	LA	M	N j6	P	S	T								
63M	8	75	60	90	M5	2,5								
71M	8	85	70	105	M6	2,5								
80M	10	100	80	120	M6	3								
90S+L	10	115	95	140	M8	3								
100L	12	130	110	160	M8	3,5								
112M	12	130	110	160	M8	3,5								
132S+M	12	165	130	200	M10	3,5								

# IE3/ IE2

## Surface-cooled low voltage motors

### Self-cooling with axial fan

Noise class 2 and 3  
Type IM B3, IM B6, IM B7, IM B8, IM V5<sup>1)</sup>, IM V6

132

Self-cooling image

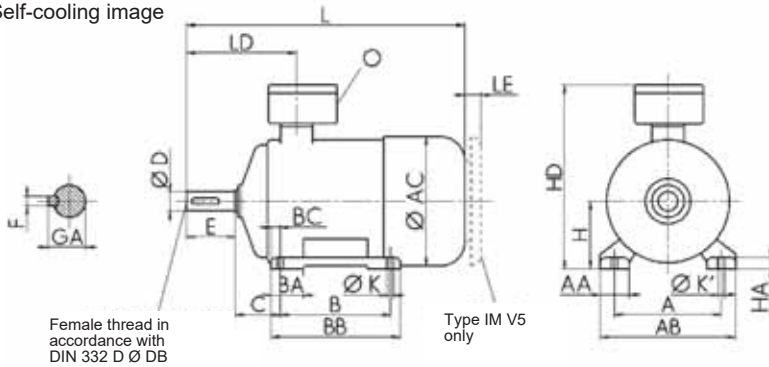

All motors with lifting eyes.  
Dimension AC, measured above bolt head.  
Dimension HD in relation to Ex e terminal compartment.  
Terminal compartment, rotatable 4 x 90°.

Note:  
1) Type IM V5 with protective roof;  
Dimension LE see page 119.

Type CD...Y3A/YA/Y2A CD...Y3AR/YAR/Y2AR	A	AA	AB	AC	B	BA	BB	BC	C	H-0,5	HA	HD	K H17	K' H17
132S	216	60	266	265	140	60	187	23,5	89	132	20	393	Ø 12	-
132S1	216	60	266	265	140	60	187	23,5	89	132	20	393	Ø 12	-
132S2	216	60	266	265	140	60	187	23,5	89	132	20	393	Ø 12	-
132M	216	60	266	265	178	60	225	23,5	89	132	20	393	Ø 12	-
160M	254	65	310	318	210	100	300	23	108	160	25	459	15	20
160L Y2	254	65	310	318	254	100	300	23	108	160	25	459	15	20
160L Y3/Y	254	65	310	318	254	100	300	23	108	160	25	459	15	20
180M	279	75	350	353	241	100	340	30	121	180	25	545	15	20
180L Y2	279	75	350	353	279	100	340	30	121	180	25	545	15	20
180L Y3/Y	279	75	350	353	279	100	340	30	121	180	25	545	15	20
200L	318	80	390	393	305	90	365	30	133	200	30	581	20	26
type CD...Y3A/YA/Y2A CD...Y3AR/YAR/Y2AR	A	AA	AB	AC	B	BA	BB	BC	C	H	HA	HD	K H17	K' H17
225S	356	85	450	455	286	90	370	29,5	149	225-0,5	35	634	20	26
225M	356	85	450	455	311	90	370	29,5	149	225-0,5	35	634	20	26
250M	406	105	510	493	349	110	420	35,5	168	250-0,5	40	731	26	35
280S	457	110	570	548	368	120	500	40,5	190	280-1	45	802	26	35
280M	457	110	570	548	419	120	500	40,5	190	280-1	45	802	26	35
315S	508	150	630	635	406	210	615	53	216	315-1	40	897	39	30
315M	508	150	630	635	457	210	615	53	216	315-1	40	897	39	30
315L1	508	150	630	635	508	210	615	53	216	315-1	40	897	39	30
315L2	508	150	630	635	508	210	615	53	216	315-1	40	897	39	30
315L3	508	150	630	635	508	210	615	53	216	315-1	40	897	39	30
type CD...XY2A/XY3A/XYA CD...XY2AR/XY3AR/XYAR ****	A	AA	AB	AC	B	BA	BB	BC	C	H	HA	HD	K H17	K' H17
250S	406	110	510	493	311	110	420	30	168	250-0,5	45	731	Ø 26,5	-
250M	406	110	510	548	349	110	420	30	168	250-0,5	45	762	Ø 26,5	-
280S	457	110	570	548	368	120	500	40,5	190	280-1	45	802	26	35
280M	457	110	570	635	419	-	570	40	190	280-1	48	862	Ø 26,5	-
315S	508	150	630	635	406	210	615	53	216	315-1	40	897	39	30
315M	508	150	630	635	457	210	615	53	216	315-1	40	897	39	30
315L1	508	150	630	635	508	210	615	53	216	315-1	40	897	39	30

\*\*\*\* British version

Note:

- 2) For type 250 to 315-4 dimension DA, EA, GC, FA and DC the specifications of number of poles 2 apply.
- 3) With pole-changing motors (4/2, 6/4 and 8/4), the 4-pole shaft end is always installed. Exception: Size 355, 400 and 450 motors with pole reversal 4/2. The 2-pole shaft end is used here. The length dimension L corresponds to the 4-pole motors for all sizes.

Type	L		LD		O	Shaft end		E	GA	F	DB			
CD...Y3A/YA/Y2A	Number of poles					D								
CD...Y3AR/YAR/Y2AR	2	4	2	4										
132S	-	582	226		M32x1,5	38 k6		80	41	10	M12			
132S1	582	-	226		M32x1,5	38 k6		80	41	10	M12			
132S2	632	-	226		M32x1,5	38 k6		80	41	10	M12			
132M	-	632	226		M32x1,5	38 k6		80	41	10	M12			
160M	732	732	261		M40x1,5	42 k6		110	45	12	M16			
160L Y2	732	732	261		M40x1,5	42 k6		110	45	12	M16			
160L Y3/Y	732	767	261		M40x1,5	42 k6		110	45	12	M16			
180M	741	741	369		M40x1,5	48 k6		110	51,5	14	M16			
180L Y2	-	755	369		M40x1,5	48 k6		110	51,5	14	M16			
180L Y3/Y	-	805	369		M40x1,5	48 k6		110	51,5	14	M16			
200L	795	815	390		M50x1,5	55 m6		110	59	16	M20			
Type	L		LD		O	Shaft end		E, EA <sup>2)</sup>	GA, GC <sup>2)</sup>	F, FA <sup>2)</sup>	DB, DC <sup>2)</sup>			
CD...Y3A/YA/Y2A	Number of poles					D <sub>m6</sub> , DA <sub>m6</sub> <sup>2)</sup>								
CD...Y3AR/YAR/Y2AR	2	4	2	4		2	4	2	4	2	4			
225S	-	932	-	377	M50x1,5	-	60	-	140	-	18	-	M20	
225M	902	932	347	377	M50x1,5	55	60	110	140	59	64	16	18	M20
250M	1014	1014	482	482	M63x1,5	60	65	140	140	64	69	18	18	M20
280S	1123	1123	483	483	M63x1,5	65	75	140	140	69	79,5	18	20	M20
280M	1123	1123	483	483	M63x1,5	65	75	140	140	69	79,5	18	20	M20
315S	1232	1294	496	526	M63x1,5	65	80	140	170	69	85	18	22	M20
315M	1232	1294	496	526	M63x1,5	65	80	140	170	69	85	18	22	M20
315L1	1232	1294	496	526	M63x1,5	65	80	140	170	69	85	18	22	M20
315L2	1432	1494	496	526	M63x1,5	65	80	140	170	69	85	18	22	M20
315L3	1432	1494	496	526	M63x1,5	65	80	140	170	69	85	18	22	M20
Type	L		LD		O	Shaft end		E, EA <sup>2)</sup>	GA, GC <sup>2)</sup>	F, FA <sup>2)</sup>	DB, DC <sup>2)</sup>			
CD...XY2A/XY3A/XYA	Number of poles					D <sub>m6</sub> , DA <sub>m6</sub> <sup>2)</sup>								
CD...XY2AR/XY3AR/XYAR	2	4	2	4		2	4	2	4	2	4			
****														
250S	1014	1014	482	482	M63x1,5	60	65*	140	140	64	69*	18	18*	M20
250M	1123	1123	483	483	M63x1,5	60	65*	140	140	64	69*	18	18*	M20
280S	1123	1123	483	483	M63x1,5	65	75**	140	140**	69	79,5**	18	20**	M20
280M	1232	1294	496	526	M63x1,5	65	75**	140	140**	69	79,5**	18	20**	M20
315S	1232	1294	496	526	M63x1,5	65	80***	140	170	69	85***	18	22	M20
315M	1232	1294	496	526	M63x1,5	65	80***	140	170	69	85***	18	22	M20
315L1	1432	1494	496	526	M63x1,5	65	80***	140	170	69	85***	18	22	M20

\* Diameter 70 for British version by request - please note: Dimension GA becomes 74.5 and dimension F becomes 20

\*\* Diameter 80 for British version by request - please note: Dimensions L, LC, LD and E become 30mm longer, dimension GA becomes 85 and dimension F becomes 22

\*\*\* Diameter 85 for British version by request - please note: Dimension GA becomes 90 and dimension F corresponds to the catalog

\*\*\*\* British version

# IE1 Self-cooling with axial

Noise class 2 and 3  
Type IM B3, IM B6, IM B7, IM B8, IM V5<sup>1)</sup>, IM V6

134

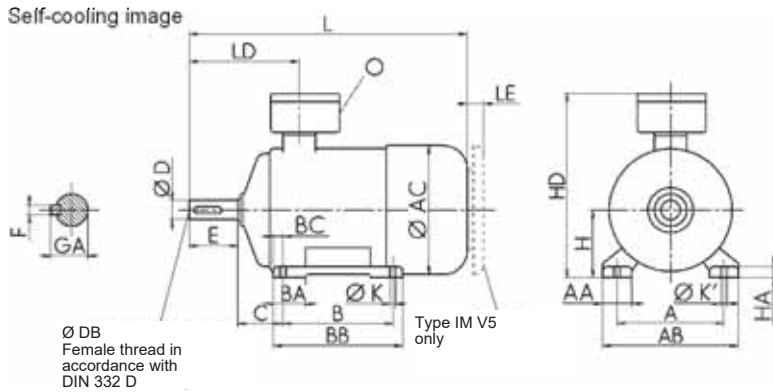

All motors with lifting eyes.  
Dimension AC measured above screw heads.  
Dimension HD in relation to Ex e terminal compartment. Terminal compartment, rotatable 4 x 90°.  
Also applies to BD series...

Note:  
1) Protective roof required for type IM V5, see dimension LE on page 117.  
2) With pole-changing motors (4/2, 6/4 and 8/4), the 4-pole  
3) Shaft end installed. Exception: Size 355, 400 and 450 motors with pole reversal 4/2.  
The 2-pole shaft end is used here. The length dimension L corresponds to the 4-pole motors for all sizes.

Type CD...A CD...AR	A	AA	AB	AC	B	BA	BB	BC	C	H -0,5	HA	HD	K H17	K' H17
132S	216	60	266	265	140	60	187	23,5	89	132	20	393	Ø 12	-
132M	216	60	266	265	178	60	225	23,5	89	132	20	393	Ø 12	-
160M	254	65	310	318	210	100	300	23	108	160	25	459	15	20
160L	254	65	310	318	254	100	300	23	108	160	25	459	15	20
180M	279	75	350	353	241	100	340	30	121	180	25	545	15	20
180L	279	75	350	353	279	100	340	30	121	180	25	545	15	20
200L	318	80	390	393	305	90	365	30	133	200	30	581	20	26
Type CD...A CD...AR	A	AA	AB	AC	B	BA	BB	BC	C	H	HA	HD	K H17	K' H17
225S	356	85	450	455	286	90	370	29,5	149	225-0,5	35	634	20	26
225M	356	85	450	455	311	90	370	29,5	149	225-0,5	35	634	20	26
250M	406	105	510	493	349	110	420	35,5	168	250-0,5	40	731	26	35
280S	457	110	570	548	368	120	500	40,5	190	280-1	45	802	26	35
280M	457	110	570	548	419	120	500	40,5	190	280-1	45	802	26	35
315S	508	150	630	635	406	210	615	53	216	315-1	40	897	39	30
315M	508	150	630	635	457	210	615	53	216	315-1	40	897	39	30
315L1	508	150	630	635	508	210	615	53	216	315-1	40	897	39	30
315L2	508	150	630	635	508	210	615	53	216	315-1	40	897	39	30
315L3	508	150	630	635	508	210	615	53	216	315-1	40	897	39	30
355L1	610	180	720	725	630	220	720	45	254	355-1	50	1084	30	39
355L2	610	180	720	725	630	220	720	45	254	355-1	50	1084	30	39
355L3	610	180	720	725	630	220	720	45	254	355-1	50	1084	30	39

type CD...A CD...AR	L Number of poles		LD		O	Shaft end D		E	GA	F	DB				
	2	4	2	4		2	4								
132S	582	582	226		M32x1,5	38k6	80	41	10	M12					
132M	-	582	226		M32x1,5	38k6	80	41	10	M12					
160M	732	732	261		M40x1,5	42k6	110	45	12	M16					
160L	732	732	261		M40x1,5	42k6	110	45	12	M16					
180M	741	754	369		M40x1,5	48k6	110	51,5	14	M16					
180L	-	754	369		M40x1,5	48k6	110	51,5	14	M16					
200L	795	815	390		M50x1,5	55m6	110	59	16	M20					
type CD...A CD...AR	L Number of poles		LD		O	Shaft end D		E	GA	F	DB				
	2	4	2	4		2	4					2	4	2	4
225S	-	932	-	377	M50x1,5	-	60	-	140	-	64	-	18	-	M20
225M	902	932	347	377	M50x1,5	55	60	110	140	59	64	16	18	M20	M20
250M	1014	1014	482	482	M63x1,5	60	65	140	140	64	69	18	18	M20	M20
280S	1123	1123	483	483	M63x1,5	65	75	140	140	69	79,5	18	20	M20	M20
280M	1123	1123	483	483	M63x1,5	65	75	140	140	69	79,5	18	20	M20	M20
315S	1232	1294	496	526	M63x1,5	65	80	140	170	69	85	18	22	M20	M20
315M	1232	1294	496	526	M63x1,5	65	80	140	170	69	85	18	22	M20	M20
315L1	1232	1294	496	526	M63x1,5	65	80	140	170	69	85	18	22	M20	M20
315L2	1432	1494	496	526	M63x1,5	65	80	140	170	69	85	18	22	M20	M20
315L3	1432	1494	496	526	M63x1,5	65	80	140	170	69	85	18	22	M20	M20
355L1	1682	1682	672	702	M80x2	75	90	140	170	79,5	95	20	25	M20	M24
355L2	1682	1682	672	702	M80x2	75	90	140	170	79,5	95	20	25	M20	M24
355L3	1762	1762	672	702	M80x2	75	90	140	170	79,5	95	20	25	M20	M24

# IE3 / IE2

## Surface-cooled, low-voltage motors, self-cooling with axial fan

Noise class 2 and 3  
Type IM B5, IM V1<sup>1)</sup>, IM V3

Self-cooling image

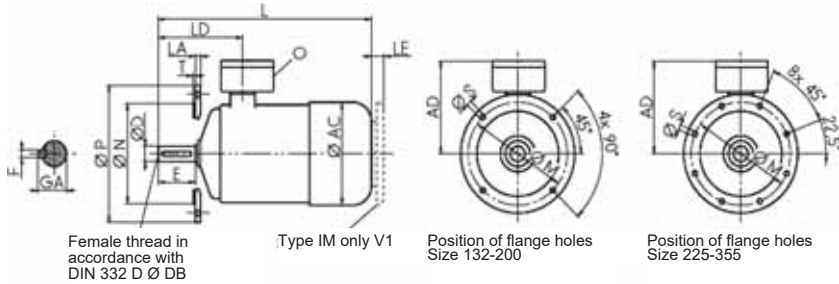

All motors with lifting eyes.  
Dimension AC, measured above bolt head.  
Dimension HD in relation to Ex e terminal compartment.  
Terminal compartment, rotatable 4 x 90°.

Note:  
1) Type IM V1 with protective roof; dimension LE see page 129.

Type	Mounting flange								L		LD		
CD...Y3A/YA/Y2A	LA	M	N	P	S	H17	T	AC	AD	Number of poles		LD	
CD...Y3AR/YAR/Y2AR										2	4	2	4
132S	16	265	230j6	300	14,5	4	265	261	261	-	582	-	226
132S1	16	265	230j6	300	14,5	4	265	261	261	582	-	226	-
132S2	16	265	230j6	300	14,5	4	265	261	261	632	-	226	-
132M	16	265	230j6	300	14,5	4	265	261	261	-	632	-	226
160M	20	300	250j6	350	18,5	5	318	299	299	732	732	261	261
160L Y2	20	300	250j6	350	18,5	5	318	299	299	732	732	261	261
160L Y3/Y	20	300	250j6	350	18,5	5	318	299	299	732	767	261	261
180M	20	300	250j6	350	18,5	5	353	365	365	741	741	369	369
180L Y2	20	300	250j6	350	18,5	5	353	365	365	-	755	-	369
180L Y3/Y	20	300	250j6	350	18,5	5	353	365	365	-	805	-	369
200L	20	350	300h6	400	18,5	5	393	381	381	795	815	390	369
type	Mounting flange								L		LD		
CD...Y3A/YA/Y2A	LA	M	N h6	P	S	H17	T	AC	AD	Number of poles		LD	
CD...Y3AR/YAR/Y2AR										2	4	2	4
225S	22	400	350	450	18,5	5	455	409	409	-	932	-	377
225M	22	400	350	450	18,5	5	455	409	409	902	932	347	377
250M	18	500	450	550	18,5	5	493	481	481	1015	1015	482	482
280S	18	500	450	550	18,5	5	548	522	522	1124	1124	483	483
280M	18	500	450	550	18,5	5	548	522	522	1124	1124	483	483
315S	22	600	550	660	24	6	635	582	582	1233	1295	496	526
315M	22	600	550	660	24	6	635	582	582	1233	1295	496	526
315L1	22	600	550	660	24	6	635	582	582	1233	1295	496	526
315L2	22	600	550	660	24	6	635	582	582	1433	1495	496	526
315L3	22	600	550	660	24	6	635	582	582	1433	1495	496	526
type	Mounting flange								L		LD		
CD...XY2A/XY3A/XYA	LA	M	N h6	P	S	H17	T	AC	AD	Number of poles		LD	
CD...XY2AR/XY3AR/XYAR										2	4	2	4
****													
250S	18	500	450	550	18,5	5	493	481	481	1014	1014	482	482
250M	18	500	450	550	18,5	5	548	476	476	1123	1123	483	483
280S	18	500	450	550	18,5	5	548	522	522	1123	1123	483	483
280M	18	500	450	550	18,5	5	635	582	582	1232	1294	496	526
315S	22	600	550	660	24	6	635	582	582	1232	1294	496	526
315M	22	600	550	660	24	6	635	582	582	1232	1294	496	526
315L1	22	600	550	660	24	6	635	582	582	1232	1294	496	526

\* Diameter 70 for British version by request - please note: Dimension GA becomes 74.5 and dimension F be

\*\* Diameter 80 for British version by request - please note: Dimensions L, LC, LD and E become 30mm longer, dimension GA becomes 85 and dimension F becomes 22

\*\*\*Diameter 85 for British version by request - please note: Dimension GA becomes 90 and dimension F corresponds to the catalog

\*\*\*\*British version

Note:

- 2) For type 250 to 315-4 dimension DA, EA, GC, FA and DC the specifications of number of poles 2 apply.
- 3) With pole-changing motors (4/2, 6/4 and 8/4), the 4-pole shaft end is always installed. Exception: Size 355, 400 and 450 motors with pole reversal 4/2. The 2-pole shaft end is used here. The length dimension L corresponds to the 4-pole motors for all sizes.

Type	LE	O	Shaft end		E	GA		F		DB				
CD...Y3A/YA/Y2A			D											
CD...Y3AR/YAR/Y2AR														
132S	30	M32x1,5	38	k6	80	41		10		M12				
132S1	30	M32x1,5	38	k6	80	41		10		M12				
132S2	30	M32x1,5	38	k6	80	41		10		M12				
132M	30	M32x1,5	38	k6	80	41		10		M12				
132M1	30	M32x1,5	38	k6	80	41		10		M12				
132M2	30	M32x1,5	38	k6	80	41		10		M12				
160M	66	M40x1,5	42	k6	110	45		12		M16				
160L Y2	66	M40x1,5	42	k6	110	45		12		M16				
160L Y3/Y	66	M40x1,5	42	k6	110	45		12		M16				
180M	66	M40x1,5	48	k6	110	51,5		14		M16				
180L Y2	66	M40x1,5	48	k6	110	51,5		14		M16				
180L Y3/Y	66	M40x1,5	48	k6	110	51,5		14		M16				
200L	77	M50x1,5	55	m6	110	59		16		M20				
Type	LE	O	Shaft end				E <sup>2)</sup>		GA <sup>2)</sup>		F <sup>2)</sup>		DB <sup>2)</sup>	
CD...Y3A/YA/Y2A			D <sub>m6<sup>2)</sup></sub>											
CD...Y3AR/YAR/Y2AR			2	4	2	4	2	4	2	4	2	4	2	4
225S	87	M50x1,5	-	60	-	140	-	64	-	18	-	-	-	M20
225M	87	M50x1,5	55	60	110	140	59	64	16	18	18	18	M20	M20
250M	94	M63x1,5	60	65	140	140	64	69	18	18	18	18	M20	M20
280S	110	M63x1,5	65	75	140	140	69	79,5	18	20	20	20	M20	M20
280M	110	M63x1,5	65	75	140	140	69	79,5	18	20	20	20	M20	M20
315S	115	M63x1,5	65	80	140	170	69	85	18	22	22	22	M20	M20
315M	115	M63x1,5	65	80	140	170	69	85	18	22	22	22	M20	M20
315L1	115	M63x1,5	65	80	140	170	69	85	18	22	22	22	M20	M20
315L2	115	M63x1,5	65	80	140	170	69	85	18	22	22	22	M20	M20
315L3	115	M63x1,5	65	80	140	170	69	85	18	22	22	22	M20	M20
Type	LE	O	Shaft end				E <sup>2)</sup>		GA <sup>2)</sup>		F <sup>2)</sup>		DB <sup>2)</sup>	
CD...XY2A/XY3A/XYA			D <sub>m6<sup>2)</sup></sub>											
CD...XY2AR/XY3AR/XYAR			2	4	2	4	2	4	2	4	2	4	2	4
****														
250S	94	M63x1,5	60	65*	140	140	64	69*	18	18*	18*	18*	M20	M20
250M	110	M63x1,5	60	65*	140	140	64	69*	18	18*	18*	18*	M20	M20
280S	110	M63x1,5	65	75**	140	140**	69	79,5**	18	20**	20**	20**	M20	M20
280M	115	M63x1,5	65	75**	140	140**	69	79,5**	18	20**	20**	20**	M20	M20
315S	115	M63x1,5	65	80***	140	170	69	85***	18	22	22	22	M20	M20
315M	115	M63x1,5	65	80***	140	170	69	85***	18	22	22	22	M20	M20
315L1	115	M63x1,5	65	80***	140	170	69	85***	18	22	22	22	M20	M20

\* Diameter 70 for British version by request - please note: Dimension GA becomes 74.5 and dimension F becomes 20

\*\* Diameter 80 for British version by request - please note: Dimensions L, LC, LD and E become 30mm longer, dimension GA becomes 85 and dimension F becomes 22

\*\*\*Diameter 85 for British version by request - please note: Dimension GA becomes 90 and dimension F corresponds to the catalog

\*\*\*\* British version

# IE1

## Surface-cooled low voltage motors

### Self-cooling with axial fan

138

Noise class 2 and 3  
Type IM B5, IM V1<sup>1)</sup>, IM V3

Self-cooling image

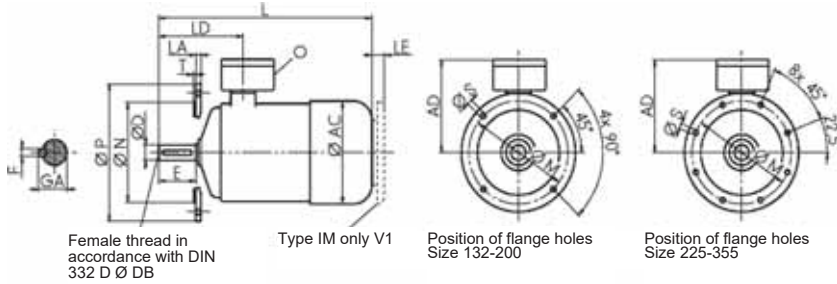

Female thread in accordance with DIN 332 D Ø DB

Type IM only V1

Position of flange holes  
Size 132-200

Position of flange holes  
Size 225-355

Mounting flange in accordance with EN 50347 Form FF. All motors with lifting eyes. Dimension AC measured above screw heads. Dimension AD in relation to Ex e terminal compartment. Terminal compartment, rotatable 4 x 90°. Also applies to BD series...

Note:

- 1) Protective roof required for type IM V1
- 2) With pole-changing motors (4/2, 6/4 and 8/4), the 4-pole shaft end is always installed. Exception: Size 355, 400 and 450 motors with pole reversal 4/2.

The 2-pole shaft end is used here. The length dimension L corresponds to the 4-pole motors for all sizes.

Type	Mounting flange								L		LD	
	CD...A CD...AR	LA	M	N	P	SH17	T	AC	AD	Number of poles 2		4
132S	16	265	230j6	300	14,5	4	265	261	582	582	226	
132M	16	265	230j6	300	14,5	4	265	261	-	582	226	
160M	20	300	250j6	350	18,5	5	318	299	732	732	261	
160L	20	300	250j6	350	18,5	5	318	299	732	732	261	
180M	20	300	250j6	350	18,5	5	353	365	741	754	369	
180L	20	300	250j6	350	18,5	5	353	365	-	754	369	
200L	20	350	300h6	400	18,5	5	393	381	795	815	390	
Type	Mounting flange								L		LD	
	CD...A CD...AR	LA	M	N h6	P	SH17	T	AC	AD	Number of poles 2	4	Number of poles 2
225S	22	400	350	450	18,5	5	455	409	-	932	-	377
225M	22	400	350	450	18,5	5	455	409	902	932	347	377
250M	18	500	450	550	18,5	5	493	481	1014	1014	482	482
280S	18	500	450	550	18,5	5	548	522	1123	1123	483	483
280M	18	500	450	550	18,5	5	548	522	1123	1123	483	483
315S	22	600	550	660	24	6	635	582	1232	1294	496	526
315M	22	600	550	660	24	6	635	582	1232	1294	496	526
315L1	22	600	550	660	24	6	635	582	1232	1294	496	526
315L2	22	600	550	660	24	6	635	582	1432	1494	496	526
315L3	22	600	550	660	24	6	635	582	1432	1494	496	526
355L1	25	740	680	800	24	6	725	729	1682	1682	672	702
355L2	25	740	680	800	24	6	725	729	1682	1682	672	702
355L3	25	740	680	800	24	6	725	729	1762	1762	672	702

Type	LE	O	Shaft end		E	GA		F		DB		
CD...A CD...AR			D			2	4	2	4	2	4	2
132S	30	M32x1,5	38k6		80		41		10		M12	
132M	30	M32x1,5	38k6		80		41		10		M12	
160M	66	M40x1,5	42k6		110		45		12		M16	
160L	66	M40x1,5	42k6		110		45		12		M16	
180M	66	M40x1,5	48k6		110		51,5		14		M16	
180L	66	M40x1,5	48k6		110		51,5		14		M16	
200L	77	M50x1,5	55m6		110		59		16		M20	
Type	LE	O	Shaft end		E	GA		F		DB		
CD...A CD...AR			D			2	4	2	4	2	4	2
225S	87	M50x1,5	-	60	-	140	-	64	-	18	-	M20
225M	87	M50x1,5	55	60	110	140	59	64	16	18	M20	M20
250M	94	M63x1,5	60	65	140	140	64	69	18	18	M20	M20
280S	110	M63x1,5	65	75	140	140	69	79,5	18	20	M20	M20
280M	110	M63x1,5	65	75	140	140	69	79,5	18	20	M20	M20
315S	115	M63x1,5	65	80	140	170	69	85	18	22	M20	M20
315M	115	M63x1,5	65	80	140	170	69	85	18	22	M20	M20
315L1	115	M63x1,5	65	80	140	170	69	85	18	22	M20	M20
315L2	115	M63x1,5	65	80	140	170	69	85	18	22	M20	M20
315L3	115	M63x1,5	65	80	140	170	69	85	18	22	M20	M20
355L1	130	M80x2	75	90	140	170	79,5	95	20	25	M20	M24
355L2	130	M80x2	75	90	140	170	79,5	95	20	25	M20	M24
355L3	130	M80x2	75	90	140	170	79,5	95	20	25	M20	M24

# Water-cooled low-voltage motors

Noise class 4

Type IM B3, IM B6, IM B7, IM B8, IM V5, IM V6

140

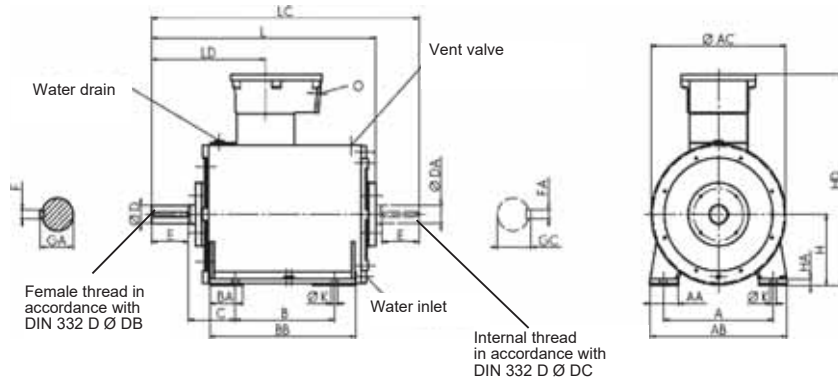

All motors with lifting eyes. Terminal compartment, rotatable 4 x 90°. Dimension HD in relation to Ex e terminal compartment.

Type	A	AA	AB	AC	B	BA	BB	BC	C	H	HA	HD	K				
160M	254	65	310	317	210	100	300	21,5	108	160-0,5	15	on request	15				
160L	254	65	310	317	254	100	300	21,5	108	160-0,5	15	on request	15				
180M	279	75	350	454	241	100	340	-	121	180-0,5	15	545	15				
180L	279	75	350	454	279	100	340	-	121	180-0,5	15	545	15				
200L	318	80	390	385	305	90	365	30	133	200-0,5	20	581	20				
225S	356	85	450	440	286	90	370	29,5	149	225-0,5	25	634	20				
225M	356	85	450	440	311	90	370	29,5	149	225-0,5	25	634	20				
250M	406	105	510	480	349	110	420	-	168	250-0,5	30	721	26				
280S	457	110	570	536	368	120	500	80,5	190	280-1	35	791	26				
280M	457	110	570	536	419	120	500	80,5	190	280-1	35	791	26				
315S	508	150	630	619	406	210	615	106,5	216	315-1	35	896	30				
315M	508	150	630	619	457	210	615	106,5	216	315-1	35	896	30				
315L1	508	150	630	619	508	210	615	106,5	216	315-1	35	896	30				
315L2	508	150	630	619	508	210	615	106,5	216	315-1	35	896	30				
355M	610	130	720	702	560	220	720	151,5	254	355-1	35	1084	30				
355L1	610	130	720	702	630	220	720	151,5	254	355-1	35	1084	30				
355L2	610	130	720	702	630	220	720	151,5	254	355-1	35	1084	30				
type	L poles	LC poles	LD poles	O	Shaft end		D, DA		E, EA		GA, GC		F, FA		DB, DC		
CD...W	2, 4, 6, 8	2, 4, 6, 8	2, 4, 6, 8	2, 4, 6, 8	2	4, 6, 8	2	4, 6, 8	2	4, 6, 8	2	4, 6, 8	2	4, 6, 8	2	4, 6, 8	
160M	614	614	755	755	261	261	M40x1,5	42k6	42k6	110	110	45	45	12	12	M16	M16
160L	614	614	755	755	261	261	M40x1,5	42k6	42k6	110	110	45	45	12	12	M16	M16
180M	643	643	773	773	369	369	M40x1,5	48k6	48k6	110	110	51,5	51,5	14	14	M16	M16
180L	643	643	773	773	369	369	M40x1,5	48k6	48k6	110	110	51,5	51,5	14	14	M16	M16
200L	660	660	773	773	390	390	M50x1,5	55m6	55m6	110	110	59	59	16	16	M20	M20
225S	-	771	-	931	-	377	M50x1,5	-	60m6	-	140	-	64	-	18	-	M20
225M	741	771	871	931	347	377	M50x1,5	55m6	60m6	110	140	59	64	16	18	M20	M20
250M	880	880	1040	1040	482	482	M63x1,5	60m6	65m6	140	140	64	69	18	18	M20	M20
280S	983	983	1143	1143	436	436	M63x1,5	65m6	75m6	140	140	69	79,5	18	20	M20	M20
280M	983	983	1143	1143	436	436	M63x1,5	65m6	75m6	140	140	69	79,5	18	20	M20	M20
315S	1093	1123	1248	1308	496	526	M63x1,5	65m6	80m6	140	170	69	85	18	22	M20	M20
315M	1093	1123	1248	1308	496	526	M63x1,5	65m6	80m6	140	170	69	85	18	22	M20	M20
315L1	1093	1123	1248	1308	496	526	M63x1,5	65m6	80m6	140	170	69	85	18	22	M20	M20
315L2	1293	1323	1448	1508	496	526	M63x1,5	65m6	80m6	140	170	69	85	18	22	M20	M20
355M	1451	1481	1648	1978	672	702	M80x2	75m6	90m6	140	170	79,5	95	20	25	M20	M24
355L1	1451	1481	1648	1978	672	702	M80x2	75m6	90m6	140	170	79,5	95	20	25	M20	M24
355L2	1451	1481	1648	1978	672	702	M80x2	75m6	90m6	140	170	79,5	95	20	25	M20	M24

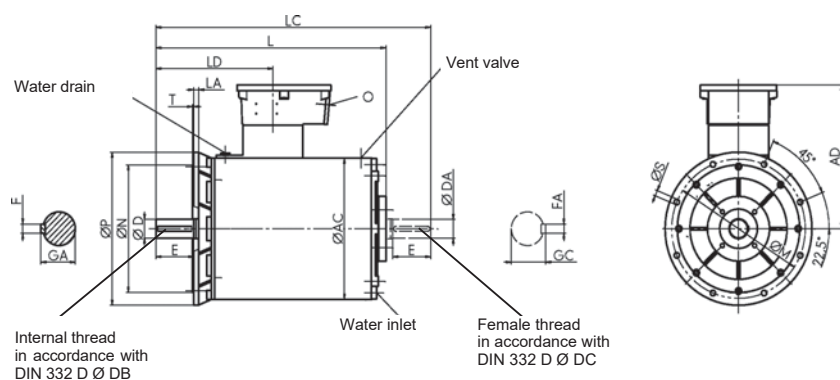

Mounting flange in accordance with EN 50347 Form FF. All motors with lifting eyes. Dimension AD in relation to Ex e terminal compartment. Terminal compartment, rotatable 4 x 90°.

Note:

- 1) With pole-changing motors (4/2, 6/4 and 8/4), the 4-pole shaft end is always installed. Exception: Size 355, 400 and 450 motors with pole reversal 4/2. The 2-pole shaft end is used here. The length dimension L corresponds to the 4-pole motors for all sizes.

type CD...W	Mounting flange		N	P	SH17	T	AC	AD
	LA	M						
160M	20	300	250j6	350	18,5	5	317	by request
160L	20	300	250j6	350	18,5	5	317	by request
180M	20	300	250j6	350	18,5	5	454	365
180L	20	300	250j6	350	18,5	5	454	365
200L	20	350	300h6	400	18,5	5	385	381
225S	22	400	350h6	450	18,5	5	440	409
225M	22	400	350h6	450	18,5	5	440	409
250M	18	500	450h6	550	18,5	5	480	471
280S	18	500	450h6	550	18,5	5	536	511
280M	18	500	450h6	550	18,5	5	536	511
315S	22	600	550h6	660	24	6	619	581
315M	22	600	550h6	660	24	6	619	581
315L1	22	600	550h6	660	24	6	619	581
315L2	22	600	550h6	660	24	6	619	581
355M	25	740	680h6	800	24	6	702	729
355L1	25	740	680h6	800	24	6	702	729
355L2	25	740	680h6	800	24	6	702	729

# Surface-cooled low voltage motors

Surface-cooled motors with integrated frequency converter

142

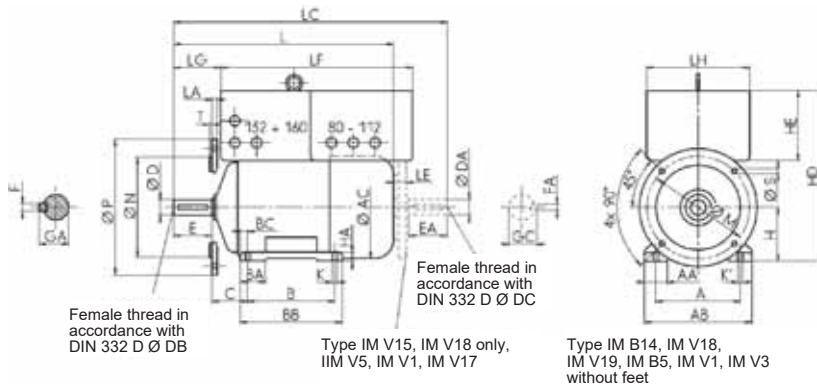

Mounting flange in accordance with EN 50347  
All motors with lifting eyes.  
Dimension AC measured above screw heads.

Note:  
1) Models IM V1, IM V5, IM V15, IM V17 and IM V18 with protective roof  
2) With pole-changing motors (4/2, 6/4 and 8/4), the 4-pole shaft end is always installed. Exception: Size 355, 400 and 450 motors with pole reversal 4/2.  
The 2-pole shaft end is used here. The length dimension L corresponds to the 4-pole motors for all sizes.

Type	CD...YI	A	AA	AB	AC	B	BA	BB	BC	C	H-0,5	HA	HD	K H17	K' H17	L	LC	LE	LF	LG	LH	HE	Gewicht ca. [kg]
80M		125	35	160	158	100	37	130	15	50	80	12	365	Ø 10	-	343	417	25	355	46	274	237	78
90S		140	40	180	178	100	44	130	15	56	90	12	378	Ø 10	-	398	479	25	355	67	274	237	91
90L		140	40	180	178	125	44	155	15	56	90	12	378	Ø 10	-	398	479	25	355	67	274	237	91
100L		160	45	200	198	140	46	175	17,5	63	100	15	410	Ø 12	-	419	515	30	355	79	274	237	102
112M		190	50	235	218	140	46	175	17,5	70	112	17	420	Ø 12	-	517	608	30	355	84	274	237	127
132S		216	59	264	258	140	56	187	23,5	89	132	20	459	Ø 12	-	534	650	30	355	139	274	237	127
type	Shaft end	Desings IM B35, IM B5, IM V1 <sup>1)</sup> , IM V3, IM V15 <sup>1)</sup> , IM V35																					
CD...YI	D, DA	E, EA	GA, GC	F, FA	DB, DC	LA	M	N j6	P	S	H17	T											
80M	19j6	40	21,5	6	M6	12	165	130	200	12	3,5												
90S+L	24j6	50	27	8	M8	12	165	130	200	12	3,5												
100L	28j6	60	31	8	M10	16	215	180	250	14,5	4												
112M	28j6	60	31	8	M10	16	215	180	250	14,5	4												
132S	38k6	80	41	10	M12	16	265	230	300	14,5	4												
type	Desings IM B14, IM V18 <sup>1)</sup> , IM V19, IM B34, IM V17 <sup>1)</sup> , IM V37																						
CD...YI	LA	M	N j6	P	S	T																	
80M	10	100	80	120	M6	3																	
90S+L	10	115	95	140	M8	3																	
100L	12	130	110	160	M8	3,5																	
112M	12	130	110	160	M8	3,5																	
132S	12	165	130	200	M10	3,5																	

# Motors with built-in brake

## Motors with encoder

all designs

143

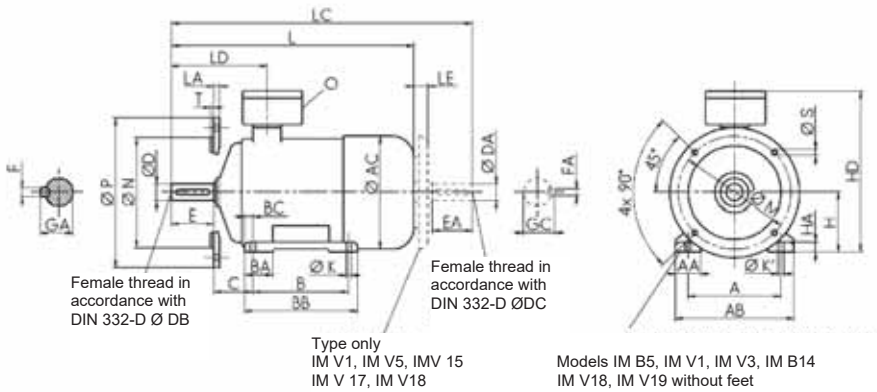

Mounting flange in accordance with EN 50347 Form FF/FT.  
All motors with lifting eyes.  
Dimension AC measured above screw heads.  
Dimension HD in relation to Ex e terminal compartment. Terminal compartment, rotatable 4 x 90°.

Type	A	AA	AB	AC	B	BA	BB	BC	C	H-0,5	HA	HD	KH17	L	LC	LD	LE
<b>80M</b>	125	35	160	177	100	35	130	15	50	80	12	260	Ø 10	411	480	127	25
<b>90S</b>	140	40	180	194	100	40	130	15	56	90	12	275	Ø 10	472	553	139	25
<b>90L</b>	140	40	180	194	125	40	155	15	56	90	12	275	Ø 10	472	553	139	25
<b>100L</b>	160	45	200	220	140	45	175	17,5	63	100	15	305	Ø 12	502	598	154	30
<b>112M</b>	190	50	235	260	140	50	175	17,5	70	112	17	317	Ø 12	600	692	189	30
<b>132S</b>	216	60	266	265	140	60	187	23,5	89	132	20	393	Ø 12	621	720	226	30
<b>132M</b>	216	60	266	265	178	60	225	23,5	89	132	20	393	Ø 12	621	720	226	30

Type	BD...Y3B(R)	Shaft end										
		O	D	DA	E	EA	GA	GC	F	FA	DB	DC
<b>80M</b>		M25x1,5	19j6	19j6	40	40	21,5	21,5	6	6	M6	M6
<b>90S+L</b>		M25x1,5	24j6	24j6	50	50	27	27	8	8	M8	M8
<b>100L</b>		M32x1,5	28j6	28j6	60	60	31	31	8	8	M10	M10
<b>112M</b>		M32x1,5	28j6	28j6	60	60	31	31	8	8	M10	M10
<b>132S+M</b>		M32x1,5	38k6	28j6	80	60	41	31	10	8	M12	M10

Type	BD...Y3B(R)	FF-flanges						
		LA	M	N j6	P	SH17	T	LE
<b>80M</b>		12	165	130	200	12	3,5	25
<b>90S+L</b>		12	165	130	200	12	3,5	25
<b>100L</b>		16	215	180	250	14,5	4	30
<b>112M</b>		16	215	180	250	14,5	4	30
<b>132S+M</b>		16	265	230	300	14,5	4	30

Type	BD...Y3B(R)	FT-flanges					
		LA	M	N j6	P	SH17	T
<b>80M</b>		10	100	80	120	M6	3
<b>90S+L</b>		10	115	95	140	M8	3
<b>100L</b>		12	130	110	160	M8	3,5
<b>112M</b>		12	130	110	160	M8	3,5
<b>132S+M</b>		12	165	130	200	M10	3,5

ATTENTION: From 01.07.2021, motors with efficiency classes IE1 and IE2 may only be supplied to the EU area as replacement motors for identical ATB motors that are already in operation.

# Motors with mounted brake Type CD... SM(N)

144

all designs

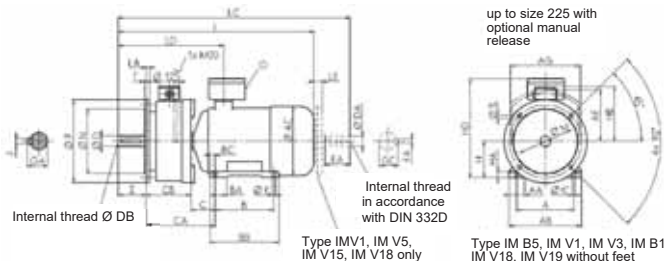

Note:  
Mounting flange in accordance with EN 50347, form FF and FT. Form FF corresponds to type B5. Form FT corresponds to type B14. With pole-changing motors (4/2, 6/4 and 8/4), the 4-pole shaft end installed. The length dimension L corresponds to the 4-pole motors for all sizes.

Type CD...SM Y3, Y, Y2	A	AA	AB	AC	AD	B	BA	BB	BC	C	H-0,5	HA	HD	K H17	K' H17	L				LD	CA	CB	
																Number of poles							
																	2	4	6	8			
71M Y3, Y, Y2	112	27	139	140	180	90	32	110	10	45	71	10	251	Ø7	-	472	472	472	472	280	216	171	
80M Y3, Y, Y2	125	35	160	158	185	100	37	130	15	50	80	12	271	Ø10	-	540	540	540	540	320	243,5	193,5	
90S Y3, Y, Y2	140	38	180	178	198	100	44	130	15	56	90	12	295	Ø10	-	592	592	592	592	333	249,5	193,5	
90L Y3, Y, Y2	140	38	180	178	198	125	44	155	15	56	90	12	295	Ø10	-	592	592	592	592	333	249,5	193,5	
100L Y3, Y, Y2	160	42	200	198	205	140	46	175	17,5	63	100	15	311	Ø12	-	631	631	631	631	366	275	212	
112M Y3, Y, Y2	190	45	235	218	225	140	46	175	17,5	70	112	17	337	Ø12	-	729	729	729	729	400	282	212	
132S Y3, Y, Y2	216	60	266	265	279	140	60	187	23,5	89	132	20	393	Ø12	-	774	774	774	774	471	334	245	
132S1 Y3, Y, Y2	216	60	266	265	279	140	60	187	23,5	89	132	20	393	Ø12	-	774	-	-	-	471	334	245	
132S2 Y3, Y, Y2	216	60	266	265	279	140	60	187	23,5	89	132	20	393	Ø12	-	824	-	-	-	471	334	245	
132M Y3, Y, Y2	216	60	266	265	279	178	60	225	23,5	89	132	20	393	Ø12	-	824	-	-	774	471	334	245	
132M1 Y3, Y, Y2	216	60	266	265	279	178	60	225	23,5	89	132	20	393	Ø12	-	-	-	774	-	471	334	245	
132M2 Y3, Y, Y2	216	60	266	265	279	178	60	225	23,5	89	132	20	393	Ø12	-	-	-	824	-	471	334	245	
160M Y3, Y, Y2	254	65	310	318	317	210	100	300	23	108	160	25	459	15	20	1012	975	975	975	560	451	299	
160L Y2	254	65	310	318	317	254	100	300	23	108	160	25	459	15	20	1012	975	975	-	560	407	299	
160L Y3,Y	254	65	310	318	317	254	100	300	23	108	160	25	459	15	20	1012	1010	1010	975	560	407	299	

Type CD...SM	A	AA	AB	AC	AD	B	BA	BB	BC	C	H-0,5	HA	HD	K H17	K' H17	L				LD	
																Number of poles					
																	2	4	6	8	
71M	112	30	139	145	164	90	25	110	10	45	71	10	235	Ø7	-	449	449	449	449	282	
80M	125	35	160	163	180	100	35	130	15	50	80	12	260	Ø10	-	540	540	540	540	309	
90S	140	40	180	183	185	100	40	130	15	56	90	12	275	Ø10	-	560	560	560	560	330	
90L	140	40	180	183	185	125	40	155	15	56	90	12	275	Ø10	-	560	560	560	560	330	
100L	160	45	200	201	205	140	45	175	17,5	63	100	15	305	Ø12	-	627	627	627	627	361	
112M	190	50	235	225	205	140	50	175	17,5	70	112	17	317	Ø12	-	641	641	641	641	366	
132S	216	60	266	265	279	140	60	187	23,5	89	132	20	393	Ø12	-	774	774	774	774	471	
132M	216	60	266	265	279	178	60	225	23,5	89	132	20	393	Ø12	-	-	774	774	774	774	471
160M	254	65	310	318	317	210	100	300	23	108	160	25	459	15	20	1012	975	975	975	560	
160L	254	65	310	318	317	254	100	300	23	108	160	25	459	15	20	1012	975	975	975	560	

type CD...SM (Y3, Y, Y2)	FF-flange			Shaft end										FT-flange					
	LA	M	N	P	S	H17	T	D	E	GA	F	DB	O	LA	M	N	P	S	T
71M (Y3, Y, Y2)	9	130	110 j6	160	10	3,5	14j5	30	16	5	M5	M25x1,5	8	85	70 j6	105	M6	2,5	
80M (Y3, Y, Y2)	12	165	130 j6	200	12	3,5	19j5	40	21,5	6	M6	M25x1,5	10	100	80 j6	120	M6	3	
90S (Y3, Y, Y2)	12	165	130 j6	200	12	3,5	24j5	50	27	8	M8	M25x1,5	10	115	95 j6	140	M8	3	
90L (Y3, Y, Y2)	12	165	130 j6	200	12	3,5	24j5	50	27	8	M8	M25x1,5	10	115	95 j6	140	M8	3	
100L (Y3, Y, Y2)	16	215	180 j6	250	14,5	4	28j5	60	31	8	M10	M32x1,5	12	130	110 j6	160	M8	3,5	
112M (Y3, Y, Y2)	16	215	180 j6	250	14,5	4	28j5	60	31	8	M10	M32x1,5	12	130	110 j6	160	M8	3,5	
132S (Y3, Y, Y2)	16	265	230 j6	300	14,5	4	38j5	80	41	10	M12	M32x1,5	12	165	130 j6	200	M10	3,5	
132M (Y3, Y, Y2)	16	265	230 j6	300	14,5	4	38j5	90	41	10	M12	M32x1,5	12	165	130 j6	200	M10	3,5	
160M (Y3, Y, Y2)	20	300	250 j6	350	18,5	5	42k5	110	45	12	M16	M40x1,5	-	-	-	-	-	-	-
160L (Y3, Y, Y2)	20	300	250 j6	350	18,5	5	42k5	110	45	12	M16	M40x1,5	-	-	-	-	-	-	-

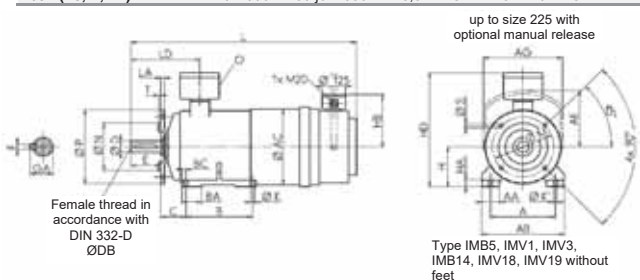

Note:  
Mounting flange in accordance with EN 50347, form FF and FT. Form FF corresponds to type B5. Form FT corresponds to type B14.

Dimensions that are not listed correspond to those of type CD...SM (Y3/Y/Y2).

With pole-changing motors (4/2, 6/4 and 8/4), the 4-pole shaft end installed. The length dimension L corresponds to the 4-pole motors for all sizes.

Type CD...SMN Y3, Y, Y2	L			
	Number of poles			
	2	4	6	8
71M Y3, Y, Y2	483	483	483	483
80M Y3, Y, Y2	578	578	-	-
90S Y3, Y, Y2	650	650	650	-
90L Y3, Y, Y2	650	650	650	-
100L Y3, Y, Y2	705	705	705	705
112M Y3, Y, Y2	790	790	790	790
132S Y3, Y, Y2	-	818	818	818
132S1 Y3, Y, Y2	818	-	-	-
132S2 Y3, Y, Y2	868	-	-	-
132M Y3, Y, Y2	-	868	-	818
132M1 Y3, Y, Y2	-	-	818	-
132M2 Y3, Y, Y2	-	-	868	-
160M Y3, Y, Y2	by request	1000	1000	1000
160L Y2	by request	1000	1000	1000
160L Y3,Y	by request	1035	1035	1000

type CD...SMN	L			
	Number of poles			
	2	4	6	8
71M	475	475	475	475
80M	535	535	535	535
90S+L	585	585	585	585
100L	680	680	680	680
112M	686	686	686	686
132S	818	818	818	818
132M	-	818	818	818
160M+L	by request	1000	1000	1000

Valid for Type CD...SMN	Weight			
	AE	AG	HB	type
71M (Y3, Y, Y2)	-	-	-	CM 71
80M (Y3, Y, Y2)	257	212	195	CM 80
90S (Y3, Y, Y2)	257	212	195	CM 90
90L (Y3, Y, Y2)	280	212	215	CM 90
100L (Y3, Y, Y2)	280	256	215	CM 112
112M (Y3, Y, Y2)	277	256	227	CM 112
132S+M (Y3, Y, Y2)	277	287	227	CM 132
160M+L (Y3, Y, Y2)	253	312	308	CM 160

# Motors with mounted brake Type CD...S, CD...SV and CD...SVN

all designs

145

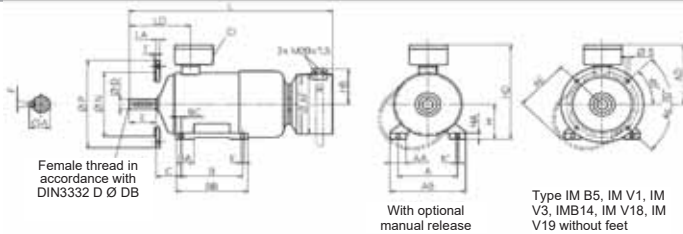

Mounting flange in accordance with EN 50347, form FF and FT. All motors with lifting eyes. Dimension AC measured above screw heads. Dimension AD in relation to

Ex e terminal compartment  
Terminal compartment, rotatable 4 x 90°. Also applies to BD series...

Type CD...S (Y3/Y/Y2)	A	AA	AB	AC	AD	B	BA	BB	BC	C	H	HA	HD	K H17	K' H17	L	LD
180M (Y3/Y/Y2)	279	75	350	353	365	241	100	340	30	121	180-0,5	25	545	15	20	924	369
180L (L-6,8 Y3/ L-6,8 Y/L-2,4,6 Y2)	279	75	350	353	365	279	100	340	30	121	180-0,5	25	545	15	20	924	369
180L-4 Y3/Y	279	75	350	353	365	279	100	340	30	121	180-0,5	25	545	15	20	by request	369
200L (Y3/Y/Y2)	318	80	390	393	381	305	90	365	30	133	200-0,5	30	581	20	26	986	390
225S (Y3/Y/Y2)	356	85	450	455	409	286	90	370	29,5	149	225-0,5	35	634	20	26	by request	request
225M (Y3/Y/Y2)	356	85	450	455	409	311	90	370	29,5	149	225-0,5	35	634	20	26	by request	request
250M (Y3/Y/Y2)	406	105	510	493	471	349	110	420	35,5	168	250-0,5	40	731	26	35	by request	request
280S (Y3/Y/Y2)	457	110	570	548	511	368	120	500	40,5	190	280-1	45	802	26	35	by request	request
280M (Y3/Y/Y2)	457	110	570	548	511	419	120	500	40,5	190	280-1	45	802	26	35	by request	request

Type CD...S (Y3/Y/Y2)	FF-flange					Shaft end					DB		O		
	LA	M	N	P	S H17 T	D	4, 6, 8	E	4, 6, 8	GA	F	4, 6, 8			
180M+L (Y3/Y/Y2)	20	300	250 j6	350	18,5 5	48 k6	48 k6	110	110	51,5	51,5	14	14	M16	M40x1,5
200L (Y3/Y/Y2)	20	350	300 h6	400	18,5 5	55 m6	55 m6	110	110	59	59	16	16	M20	M50x1,5
225S+M (Y3/Y/Y2)	22	400	350 h6	450	18,5 5	55 m6	60 m6	110	140	59	64	16	18	M20	M50x1,5
250M (Y3/Y/Y2)	18	500	450 h6	550	18,5 5	60 m6	65 m6	140	140	64	69	18	18	M20	M63x1,5
280S+M (Y3/Y/Y2)	18	500	450 h6	550	18,5 5	65 m6	75 m6	140	140	69	79,5	18	20	M20	M63x1,5

  

Type CD...S (Y3/Y/Y2)	Brake				Brake weight [kg]
	AE	AF	HB	Größe	
180M+L (Y3/Y/Y2)	215	330	205	19/24	57
200L (Y3/Y/Y2)	215	330	205	24	57

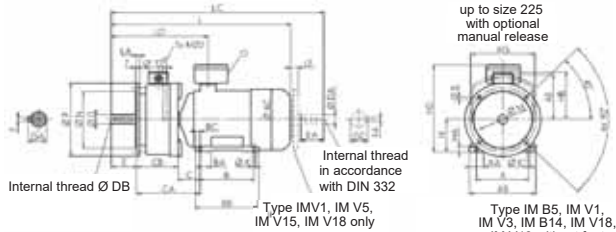

Note:  
Mounting flange in accordance with EN 50347, form FF and FT. Form FF corresponds to type B5. Form FT corresponds to type B14.  
Dimensions that are not listed correspond to the dimensions of type CD...S  
With pole-changing motors (4/2, 6/4 and 8/4), the 4-pole shaft end is always installed.  
The length dimension L corresponds to the 4-pole motors for all sizes.

Type CD...SV (Y3/Y/Y2)	L		LC		LD		CA	CB	LE	FF-flange		P ±1	S	DB	
	Number of poles	Number of poles	Number of poles	Number of poles	Number of poles	Number of poles	2	4, 6, 8	2	LA	N h8	4, 6, 8			
180M (Y3/Y/Y2)	1026	1026	1026	1209	1209	669	421	300	66	21	250	350	18	M20x30	
180L (L-6,8 Y3/ L-6,8 Y/L-2,4,6 Y2)	---	1026	1026	---	1209	669	669	421	300	66	21	250	350	18	M20x30
180L-4 Y3/Y	---	by request	1026	---	by request	669	669	421	300	66	21	250	350	18	M20x30
200L (Y3/Y/Y2)	1089	1089	1089	1283	1209	690	690	433	300	77	21	300	400	18	M20x30
225S+M (Y3/Y/Y2)	1237	1267	1218	1441	1505	677	707	449	300	87	21	350	448	18	M20x30
250M (Y3/Y/Y2)	1310	1310	1244	1561	1561	1495	792	478	310	94	26	450	550	18	M20x30
280S+M (Y3/Y/Y2)	1419	1419	1419	1685	1685	793	793	500	310	110	26	450	550	18	M20x30

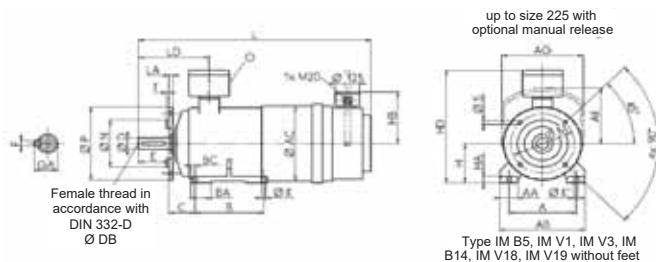

Note:  
Mounting flange in accordance with EN 50347, form FF and FT. Form FF corresponds to type B5. Form FT corresponds to type B14.

Dimensions that are not listed correspond to those of type CD...S (Y3/Y/Y2).  
With pole-changing motors (4/2, 6/4 and 8/4), the 4-pole shaft end installed.  
The length dimension L corresponds to the 4-pole motors for all sizes.

Type CD...SVN (Y3/Y/Y2)	AC	L	LD	Valid for				Brake	
				Type CD...SV (Y3/Y/Y2)	AE	AG	HB	type	Brake weight [kg]
				Type CD...SVN (Y3/Y/Y2)					
180M (Y3/Y/Y2)	by request	by request	by request	180M+L (Y3/Y/Y2)	320	370	282	180	135
180L (L-6,8 Y3/ L-6,8 Y/L-2,4,6 Y2)	by request	by request	by request	200L (Y3/Y/Y2)	320	370	282	200	150
180L-4 Y3/Y	by request	by request	by request	225S+M (Y3/Y/Y2)	320	370	282	225	175
200L (Y3/Y/Y2)	by request	by request	by request	250M (Y3/Y/Y2)	-	-	328	250	175
225S+M (Y3/Y/Y2)	by request	by request	by request						
250M (Y3/Y/Y2)	by request	by request	by request						
280S+M (Y3/Y/Y2)	by request	by request	by request						

# Surface-cooled, high-voltage motors

## Self-cooling with radial fan

146

all designs

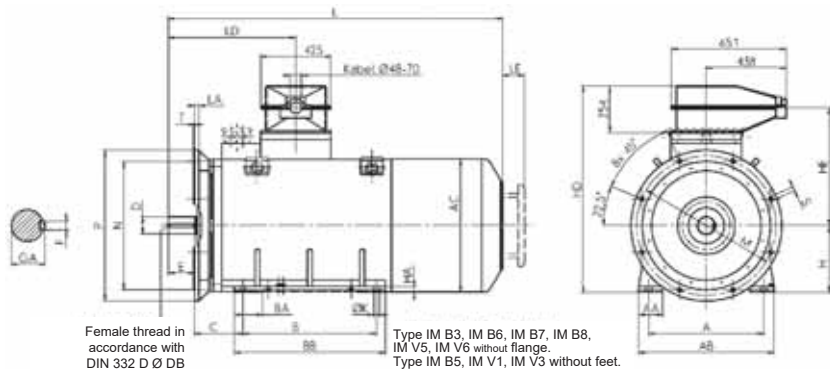

Mounting flange in accordance with EN 50347 Form FF All motors with lifting eyes.  
Dimension AC measured above screw heads. Dimension HD in relation to Ex e terminal compartment, type EAR 355 H6.

Note:  
Sizes 400 and 450 available as flange type for V1 only.

With pole-changing motors (4/2, 6/4 and 8/4), the 4-pole shaft end is always installed. Exception: Size 355, 400 and 450 motors with pole reversal 4/2. The 2-pole shaft end is used here. The length dimension L corresponds to the 4-pole motors for all sizes

Type CD...H	A	AA	AB	AC	B	BA	BB	BC	C	H-1	HA	HD	HE	K	L			LD		
															Number of poles			Number of poles		
															2	4	6, 8	2	4, 6, 8	
355M	610	180	720	725	560	220	720	45	254	355	50	1130	651	30	1667	1697	1597	672	702	
355L	610	180	720	725	630	220	720	45	254	355	50	1130	651	30	1747	1777	1597	672	702	
400M	686	130	800	810	630	150	1264	152	280	400	34	1192	668	35	1977	2047	2047	718	788	
400L	686	130	800	810	710	150	1264	152	280	400	34	1192	668	35	1977	2047	2047	718	788	
450M	760	150	900	910	710	180	1135	150	280	450	35	1310	736	35	1833	1903	1903	756	826	
450L1	760	150	900	910	840	180	1280	150	280	450	35	1310	736	35	1983	2048	2048	756	826	
450L2	760	150	900	910	840	180	1280	150	280	450	35	1310	736	35	1983	2228	2228	756	826	
450L3	760	150	900	910	840	180	1280	150	280	450	35	1310	736	35	2163	2228	2228	756	826	

Type CD...H	D m6 Number of poles		E Number of poles		GA Number of poles		F Number of poles		DB Number of poles		Mounting flange					
	2	4, 6, 8	2	4, 6, 8	2	4, 6, 8	2	4, 6, 8	2	4, 6, 8	LA	M	N h6	P	S H17	T
355M	75	90	140	170	79,5	95	20	25	M20	M24	25	740	680	800	24	6
355L	75	90	140	170	79,5	95	20	25	M20	M24	25	740	680	800	24	6
400M	75	100	140	210	79,5	106	20	28	M20	M24	28	940	880	1000	28	6
400L	75	100	140	210	79,5	106	20	28	M20	M24	28	940	880	1000	28	6
450M	75	100	140	210	79,5	116	20	28	M20	M24	28	940	880	1000	28	6
450L1	75	100	140	210	79,5	116	20	28	M20	M24	28	940	880	1000	28	6
450L2	75	100	140	210	79,5	116	20	28	M20	M24	28	940	880	1000	28	6
450L3	75	100	140	210	79,5	116	20	28	M20	M24	28	940	880	1000	28	6

# Terminal compartments up to 690 V

EAR - Ex e  
Version 1 und 3

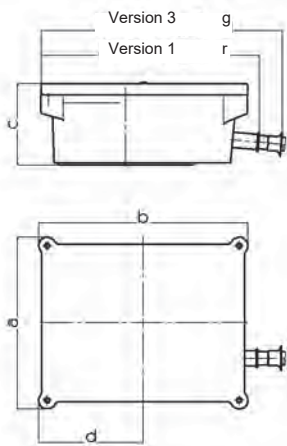

EAR - Ex e  
Version 9 (VIK)

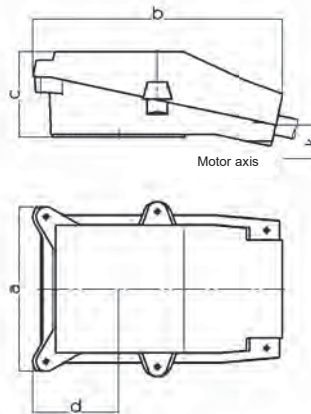

CAR - Ex d

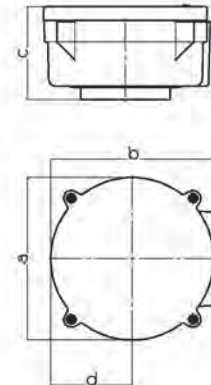

Protection class	Cable entry	EAR - Ex e Version 1 und 3						CAR - Ex d without cable version						
		Terminal compartment	a	b	c	d	r	g	Size	Terminal compartment	a	b	c	d
63	EAR 80		145	145	88	53	179	185	63	CAR 80	145	145	92	53
71	EAR 80		145	145	88	53	179	185	71	CAR 80	145	145	92	53
80	EAR 80		145	145	88	53	179	185	80	CAR 80	145	145	92	53
90	EAR 80		145	145	88	53	179	185	90	CAR 80	145	145	92	53
100	EAR 80		145	145	88	53	185	200	100	CAR 80	145	145	92	53
112	EAR 80		145	145	88	53	185	200	112	CAR 80	145	145	92	53
132	EAR 132		220	220	114	110	260	275	132	CAR 132	220	220	120	110
160	EAR 132		220	220	114	110	265	281	160	CAR 132	220	220	120	110
180	EAR 180		280	340	152	140	385	401	180	CAR 180	265	270	162	133
200	EAR 180		280	340	152	140	390	420	200	CAR 180	265	270	162	133
225	EAR 180		280	340	154	140	390	420	225	CAR 225	380	380	202	190
250	EAR 250		340	422	206	161	474	512	250	CAR 225	380	380	202	190
280	EAR 250		340	422	206	161	474	512	280	CAR 225	380	380	202	190
315	EAR 250		340	422	198	161	474	512	315	CAR 315	380	380	208	190
355	EAR 355		480	527	249	224	-	617	355	CAR 355	484	734	335	242
400	EAR 355		480	527	249	224	-	630	400	CAR 355	484	734	335	242
450	EAR 355		480	527	249	224	-	630	450	CAR 355	484	734	335	242

Protection class	Cable entry	EAR - Ex e Version 9 (VIK)					
		Terminal compartment	a	b	c	d	k
250	EAR 250		356	512	186	179	317
280	EAR 250		356	512	186	179	357
315	EAR 250		356	512	186	179	427
355	EAR 355		425	650	254	213	541
400	EAR 355		425	650	254	213	558
450	EAR 355		425	650	254	213	626

Protection class	Cable entry	EAR - Ex e Version 1 und 3						CAR - Ex d without cable version						
		Type CD...XY*	Terminal compartment	a	b	c	d	r	g	Size	Terminal compartment	a	b	c
250S	EAR 250		340	422	196	161	474	512	250S	CAR 225	380	380	202	190
250M	EAR 250		340	422	196	161	474	512	250M	CAR 225	380	380	202	190
280S	EAR 250		340	422	196	161	474	512	280S	CAR 225	380	380	202	190
280M	EAR 250		340	422	196	161	474	512	280M	CAR 315	380	380	208	190
315	EAR 250		340	422	196	161	474	512	315	CAR 315	380	380	208	190

\* British version

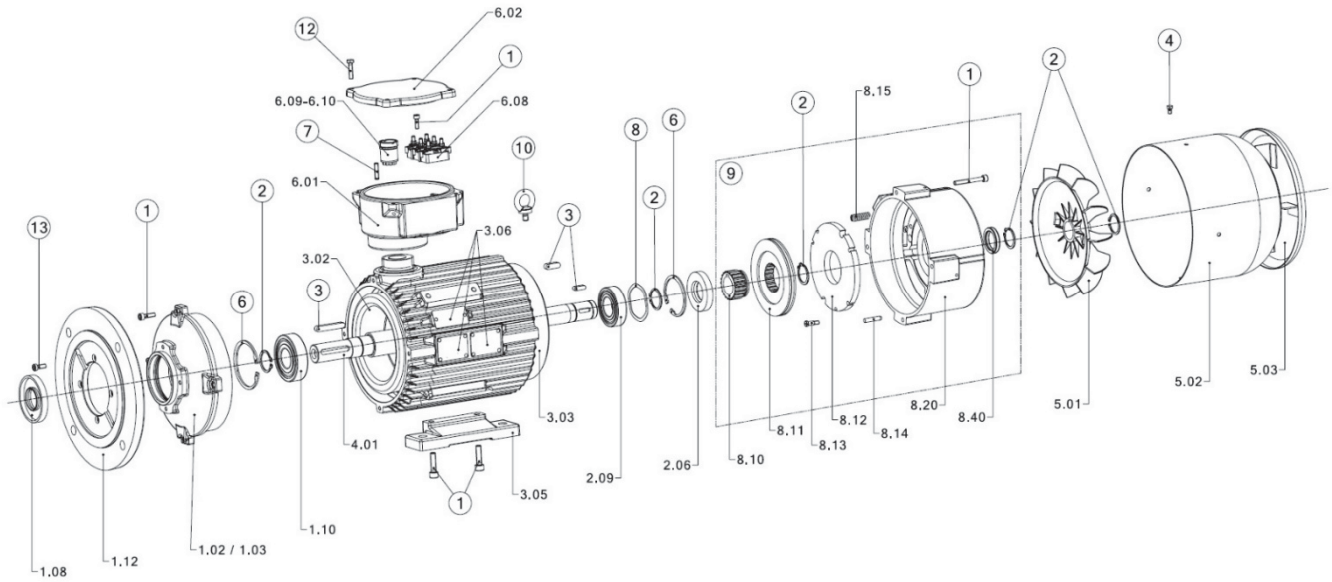

**Exploded view size 63 to 132**

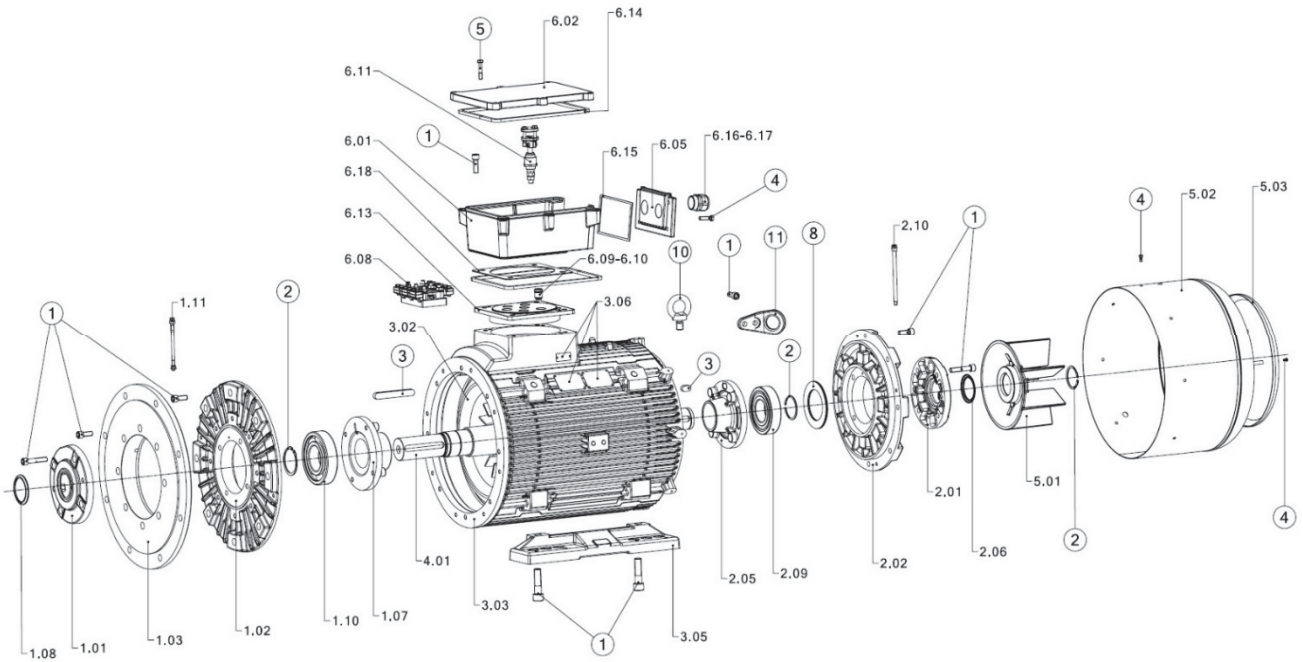

**Exploded view size from 160**

- |   |   |                                      |
|---|---|--------------------------------------|
| ① Screw according to DIN EN ISO 4762  | ⑥ Circlip according to DIN 472            | ⑪ Lifting eye                        |
| ② Circlip according to DIN 471  | ⑦ Grub screw according to DIN EN ISO 4027 | ⑫ Screw according to DIN EN ISO 4017 |
| ③ Feather key according to DIN 6885   | ⑧ Belleville washer or shim               | ⑬ Screw according to DIN 6912        |
| ④ Screw according to DIN EN ISO 4017<br>Screw according to DIN 6929<br>(recommendation) | ⑨ only for brake motors                   |                                      |
|   | ⑩ Eyebolt according to DIN                |                                      |

The spare parts that are listed are available from the factory. The design and combination depends on the motor that is supplied.

When requesting and ordering spare parts, the following information is required:

- Spare part number and designation
- Motor type and design
- Motor number

### Spare parts list

Part no.	Designation
<b>1</b>	<b>DS bearing (drive side)</b>
1.01	Bearing cover DS external
1.02	End shield DS
1.03	Flange bearing shield DS
1.07	Bearing cover DS internal
1.08	Shaft seal DS
1.10	Roller bearing DS
1.11	Relubrication DS
1.12	Flange ring
1.13	Shim according to DIN 988
1.14	Nilos Ring
<b>2</b>	<b>Bearing NS (non-drive side)</b>
2.01	Bearing cover NS external
2.02	End shield NS
2.05	Bearing cover NS internal
2.06	Shaft seal NS external
2.09	Roller bearing NS
2.10	Relubrication NS
<b>3</b>	<b>Housing</b>
3.02	Stator winding, complete
3.03	Housing
3.05	Housing feet (1 pair), machined
3.06	Signs
<b>4</b>	<b>Rotor</b>
4.01	Rotor complete
<b>5</b>	<b>Ventilation</b>
5.01	Fan
5.02	Fan guard
5.03	Canopy
<b>6</b>	<b>Terminal compartment</b>
6.01	Terminal box
6.02	Terminal box cover
6.05	Cable entry plate
6.08	Terminal board complete
6.09	Core grommet
6.10	Core grommet, PTC thermistor
6.11	Cable grommet
6.13	Feed-through plate
6.14	Junction box gasket
6.15	Gasket insertion plate
6.16	Cable entry
6.17	Cable entry, PTC thermistor
6.18	Lead-through plate gasket
<b>8</b>	<b>Brake</b>
8.10	Friction disc driver
8.11	Friction disc
8.12	Armature disk
8.13	Special screw
8.14	Special cylindrical pin
8.15	Position spring
8.20	Brake housing with coil, complete
8.30	Half-wave rectifier
8.40	Brake shaft seal
<b>9</b>	<b>Speed sensor (no illustration)</b>
9.01	Speed sensor
9.10	Torque support
9.20	Encoder housing
9.40	Oil seal

# Wiring diagram

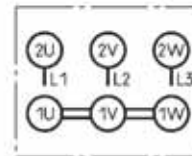
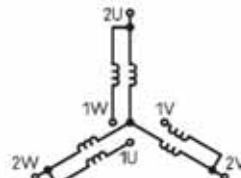
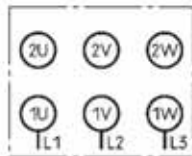
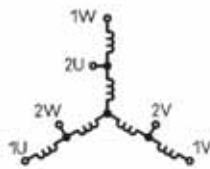
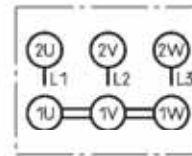
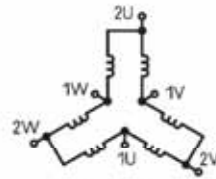
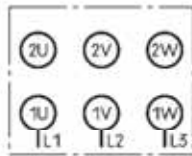
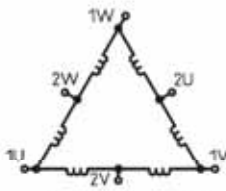
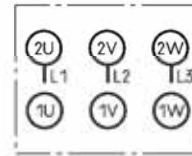
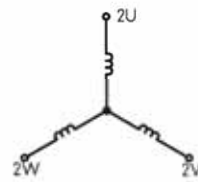
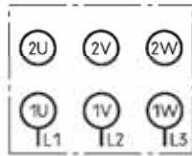
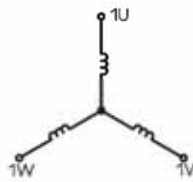
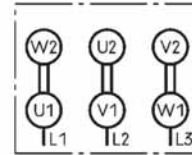
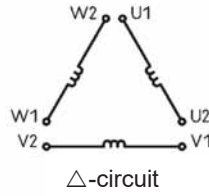
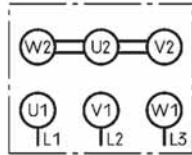
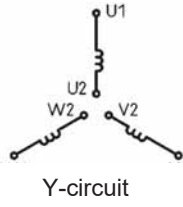

1 TP 1 - 1 TP 2	PTC thermistor prewarning	U > 2.5 V forbidden	Triggering device with marking II (2)G	Connection bolt	
2 TP 1 - 2 TP 2	PTC thermistor disconnection <sup>1)</sup>				
1 R 1 - R 2	Resistance temperature sensor PT 100 / winding  1 R 1 2 R 1 3 R 1 R 2	Resistance temperature sensor PT 100 / bearing D-side  4 R 1 4 R 2	N-side  5 R 1 5 R 2	Thread size	Tightening torque (Nm)
4 R 1 - 5 R 2				M5	2
				M6	3
				M8	6
				M10	10
				M12	15.5
1 HE 1 - 1 HE 2	Standstill heating to prevent condensation formation			M16	30
TB 1 - TB 2	Microtherm T10 thermostat switch				

Note

<sup>1)</sup> Release unit with Ex marking required

# Conversion of technical units of measurement

in SI units of measure  
(Systems Internationale d'Unité)

151

## Output

$$1 \text{ kW} = 1,36 \text{ PS} = 102 \text{ kpm/s} = 1000 \text{ Nm/s}$$

$$1 \text{ PS} = 0,736 \text{ kW} = 75 \text{ kpm/s} = 736 \text{ Nm/s}$$

## Work

$$1 \text{ kWh} = 3,6 \times 10^6 \text{ J} = 3,6 \times 10^6 \text{ Nm}$$

$$= 0,367 \times 10^6 \text{ kpm}$$

$$1 \text{ Ws} = 1 \text{ J} = 1 \text{ Nm} = 0,102 \text{ kpm}$$

## Force

$$1 \text{ N} = 0,102 \text{ kp}$$

$$1 \text{ kp} = 9,81 \text{ N}$$

## Torque

$$1 \text{ Nm} = 0,102 \text{ kpm} = 1 \text{ Ws}$$

$$1 \text{ kpm} = 9,81 \text{ Nm} = 9,81 \text{ Ws}$$

## Pressure

$$1 \text{ Pa} = 1 \text{ N/m}^2$$

$$1 \text{ bar} = 100 \text{ kPa}$$

$$1 \text{ mm water column} = 9,81 \text{ Pa}$$

## Moment of inertia

$$1 \text{ kgm}^2 = 1 \text{ Ws}^3 = 1 \text{ Nms}^2 = 0,102 \text{ kpm}^2$$

## Power (three-phase motors)

$$P_1 = U \times I \times \cos \varphi \times \sqrt{3} \times 10^{-3}$$

$$P_2 = P_1 \times \eta$$

$$P_1 = \text{Power consumed [kW]}$$

$$P_2 = \text{Power output [kW]}$$

$$U = \text{Voltage [V]}$$

$$I = \text{Current [A]}$$

$$\cos \varphi = \text{Power factor}$$

$$\eta = \text{Efficiency}$$

## Power requirements of some working machines

### Lifting movement

$$P = \frac{F \times v}{\eta} \times 10^{-3} \text{ [kW]}$$

### Rotation

$$P = \frac{M \times n}{9550 \times \eta} \text{ [kW]}$$

### Fan drive

$$P = \frac{V \times p}{\eta} \times 10^{-3} \text{ [kW]}$$

### Pump drive

$$P = \frac{V \times p}{\eta} \times 10^{-3} \text{ [kW]}$$

$$P = \text{Power [kW]}$$

$$F = \text{Force [N]}$$

$$v = \text{Velocity [m/s]}$$

$$\eta = \text{Efficiency}$$

$$M = \text{Torque [Nm]}$$

$$n = \text{Speed [rpm]}$$

$$V = \text{Flow rate [m}^3\text{/s]}$$

$$p = \text{Total counterpressure to be overcome [N/m}^2\text{]}$$

## Torques

### Torque from engine power

$$M = 9550 \frac{P_2}{n} \text{ [Nm]}$$

$$P_2 = \text{Motor power [kW]}$$

$$n = \text{Speed [rpm]}$$

### Conversion of torques in case of gear reduction or transmission

$$M_2 = \frac{M_1 \times n_1}{n_2}$$

$$n_1 = \text{Motor speed [rpm]}$$

$$M_1 = \text{Motor torque [Nm]}$$

$$n_2 = \text{Operating speed [rpm]}$$

$$M_2 = \text{Torque at } n_2 \text{ [Nm]}$$

## Moment of inertia

### Relationship to momentum

$$J = \frac{GD^2}{4}$$

$$J = \text{Moment of inertia [kgm}^2\text{]}$$

$$GD^2 = \text{Momentum [kgm}^2\text{]}$$

### Moment of inertia of masses moving in a straight line in relation to motor speed

$$J = 91,2 \times m \left(\frac{v}{n}\right)^2 \text{ [kgm}^2\text{]}$$

$$m = \text{Mass [kg]}$$

$$v = \text{Velocity [m/s]}$$

$$n = \text{Motor speed [rpm]}$$

### Conversion of moments of inertia to another speed with gear reduction or transmission

$$J_2 = J_1 \left(\frac{n_1}{n_2}\right)^2$$

$$n_1 = \text{Motor speed [rpm]}$$

$$J_1 = \text{Moment of inertia at } n_1 \text{ [kgm}^2\text{]}$$

$$n_2 = \text{Operating speed [rpm]}$$

$$J_2 = \text{Moment of inertia at } n_2 \text{ [kgm}^2\text{]}$$

## Inertia factor

$$J_l = \frac{J_{\text{mot}} + J_{\text{zus}}}{J_{\text{mot}}}$$

$$J_{\text{mot}} = \text{Moment of inertia of motor [kgm}^2\text{]}$$

$$J_{\text{zus}} = \text{Moment of inertia of driven machine [kgm}^2\text{]}$$

## Start-up time

$$t_a = \frac{J_l \times J_{\text{mot}} \times n}{9,55 \times M_b} \text{ [s]}$$

$$M_b = M_{\text{mot}} - M_{\text{geg}} \text{ [Nm]}$$

$$J_l = \text{Inertia factor}$$

$$J_{\text{mot}} = \text{Moment of inertia of motor [kgm}^2\text{]}$$

$$n = \text{Motor speed [rpm]}$$

$$M_b = \text{Acceleration torque [Nm]}$$

$$M_{\text{mot}} = \text{Motor torque during ramp-up (averaged)}$$

$$M_{\text{geg}} = \text{Counter-torque during ramp-up (averaged)}$$

## Formulas from acoustics Sound pressure level

$$L_p = 20 \log \frac{p}{p_o} \text{ [dB]}$$

### Reference sound pressure

$$p_o = 2 \times 10^{-5} \left[\frac{\text{N}}{\text{m}^2}\right]$$

### Sound power level

$$L_w = 10 \log \frac{p}{p_o} \text{ [dB]}$$

### Reference sound power

$$P_o = 10^{-12} \text{ [W]}$$

### Sound power

$$P = \frac{p^2}{\alpha \times c} A \text{ [W]}$$

### Sound characteristic impedance

$$\alpha \times c = 408 \left[\frac{\text{Ns}}{\text{m}^3}\right]$$

at 100 mbar and 20 °C

### Measuring surface dimension

$$L_s = 10 \log \frac{A}{A_o}$$

$$L_w = L_p + L_s$$

$$L_p = \text{Sound pressure level [dB]}$$

$$p = \text{Sound pressure} \left[\frac{\text{N}}{\text{m}^2}\right]$$

$$p_o = \text{Reference sound pressure}$$

$$L_w = \text{Sound power level [dB]}$$

$$P = \text{Sound power [W]}$$

$$P_o = \text{Reference sound power [W]}$$

$$A = \text{Radiating area [m}^2\text{]}$$

$$\alpha \times c = \text{Sound characteristic impedance} \left[\frac{\text{Ns}}{\text{m}^3}\right]$$

$$A_o = \text{Reference area} = 1 \text{ m}^2$$

$$L_s = \text{measurement area [dB]}$$

# Your service partner

152

## **Nordenham plant**

ATB NORDENHAM GmbH  
Helgoländer Damm 75  
D-26954 Nordenham  
Tel.: +49 4731 365 - 0  
Fax: +49 4731 365 - 159  
[info@atb-nordenham.de](mailto:info@atb-nordenham.de)  
[www.atb-nordenham.de](http://www.atb-nordenham.de)

For further contact addresses, service partners and local service workshops, please visit us on the Internet at [www.atb-nordenham.de](http://www.atb-nordenham.de).

**Publisher**

ATB NORDENHAM GmbH  
Helgoländer Damm 75  
D-26954 Nordenham  
Tel.: +49 4731 365 – 0  
Fax: +49 4731 365 – 159  
info@atb-nordenham.de  
www.atb-nordenham.de

Edition  
EXMOT 20 Rev. 02 EN

Subject to change without notice.  
Reprinting only with our written permission.

# Technology in motion

## PRESSURE-RESISTANT ENCAPSULATED THREE-PHASE MOTORS

Modern, innovative, reliable - these quality features have been driving us and our motor time and again for more than 60 years.

Thanks to our many years of experience in the development and production of explosion-proof electric motors, we have the highest level of expertise in this field of drive technology. We are therefore always in a position to creatively integrate your requirements into complex solution concepts.

This ultimately results in individually manufactured end products which are fully tailored to your needs - our custom work for your future!

- ▶ LOW VOLTAGE
- ▶ MOTORS ENERGY SAVING MOTORS
- ▶ UNIVERSAL CHEMICAL MOTORS
- ▶ COMPACT MOTORS
- ▶ HIGH VOLTAGE MOTORS
- ▶ SPECIAL MOTORS

NORDENHAM



ATB NORDENHAM GmbH

Helgoländer Damm 75  
D-26954 Nordenham  
Tel. +49 4731 365 - 0  
Fax: +49 4731 365 - 159  
info@atb-nordenham.de  
www.atb-nordenham.de



You can also find information about the individual product groups on the Internet: [www.atb-nordenham.de](http://www.atb-nordenham.de)

ExMot 20 Rev. 02 EN

**ATB**  
Technology in Motion